



EVO DESIGNED ACOUSTIC SOLUTIONS

All rights reserved by Endless Dynamic 2024 ©



Name: W-absorber

Models: EQ30 EQ60 EQ120 (Angle T / Chamfer TD)

Base Material: 100% eco-friendly acoustic composite fiber wool

Finish: SF, UA, YC, XY fabric acoustic cloth surface finishing

Eco-Friendly: Zero Formaldehyde emission, Enf standard

Weight: EQ30 ~ 4.8 Kg /m² EQ60 ~ 7 Kg /m² EQ120 ~ 13 Kg /m²

Made for broadband frequency acoustic treatment in different spaces, being able to form a diffusing wall or low frequency trap easily.

Its double bandwidth suits with broadband frequency sound absorber accompany a surface in the ratio of 1:1 (absorption: diffusion).

Designed in a modular form allows different configurations and combinations achieving both aesthetics and acoustic space. It is easy to install and will preserve a natural acoustic ambiance.

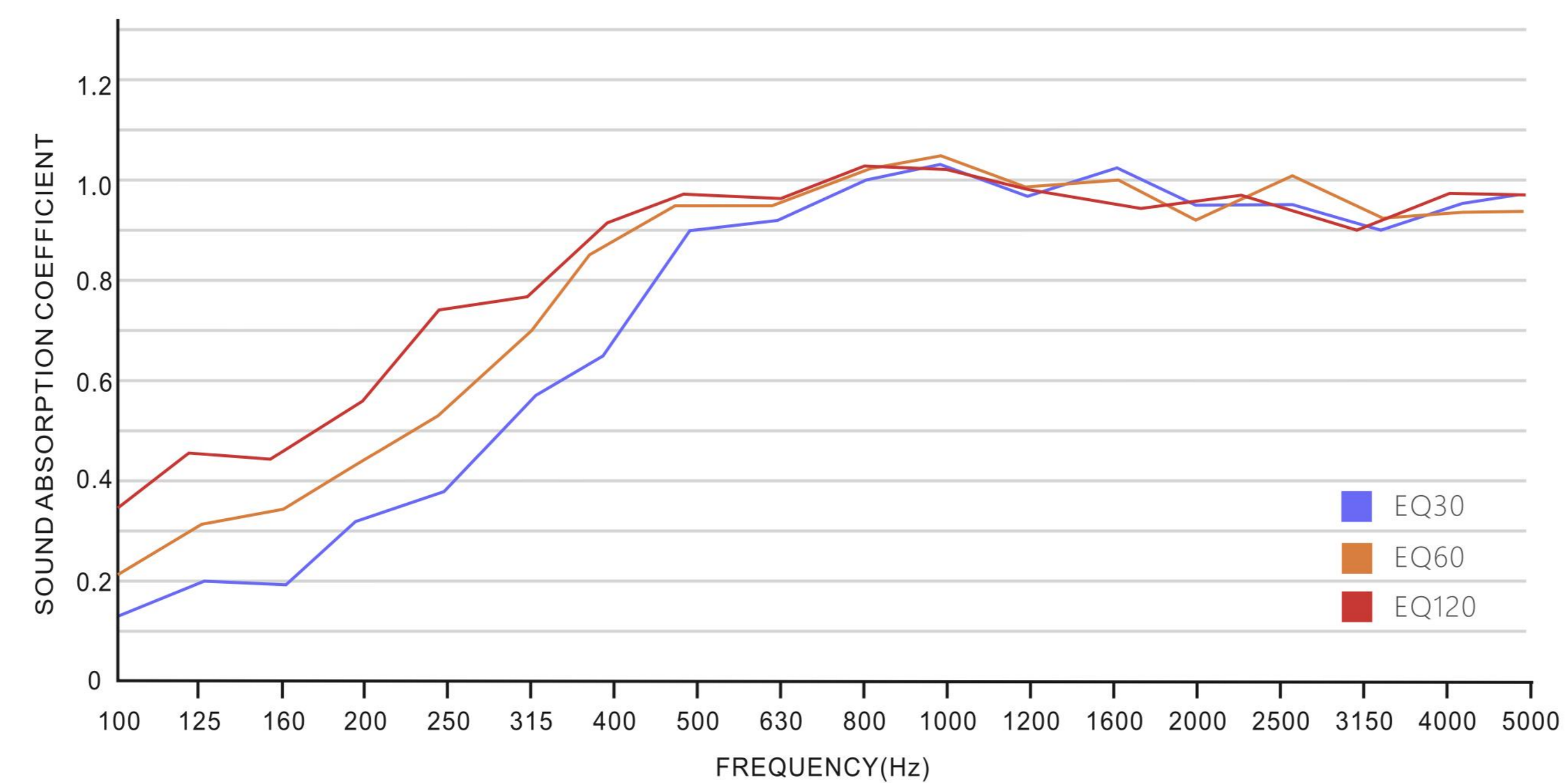

Model

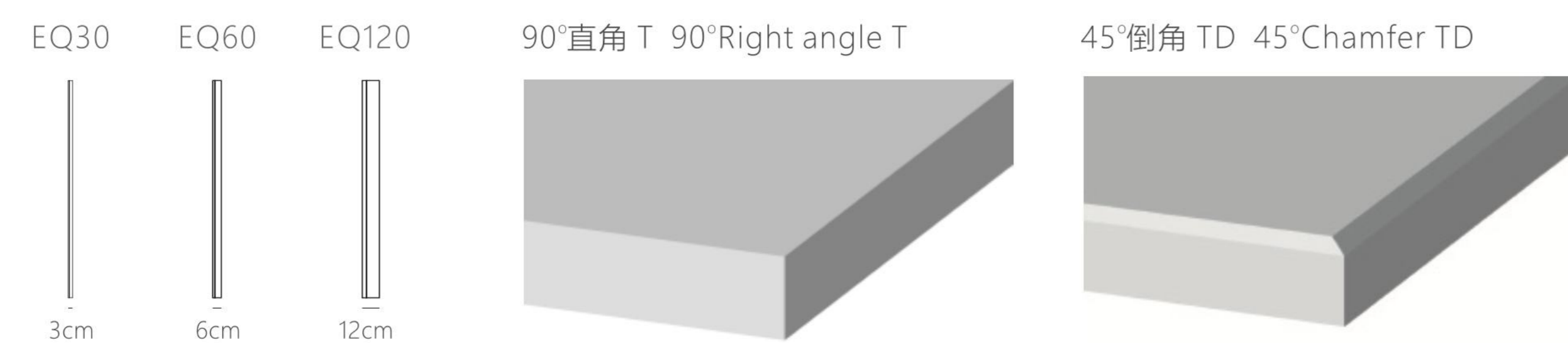

Size

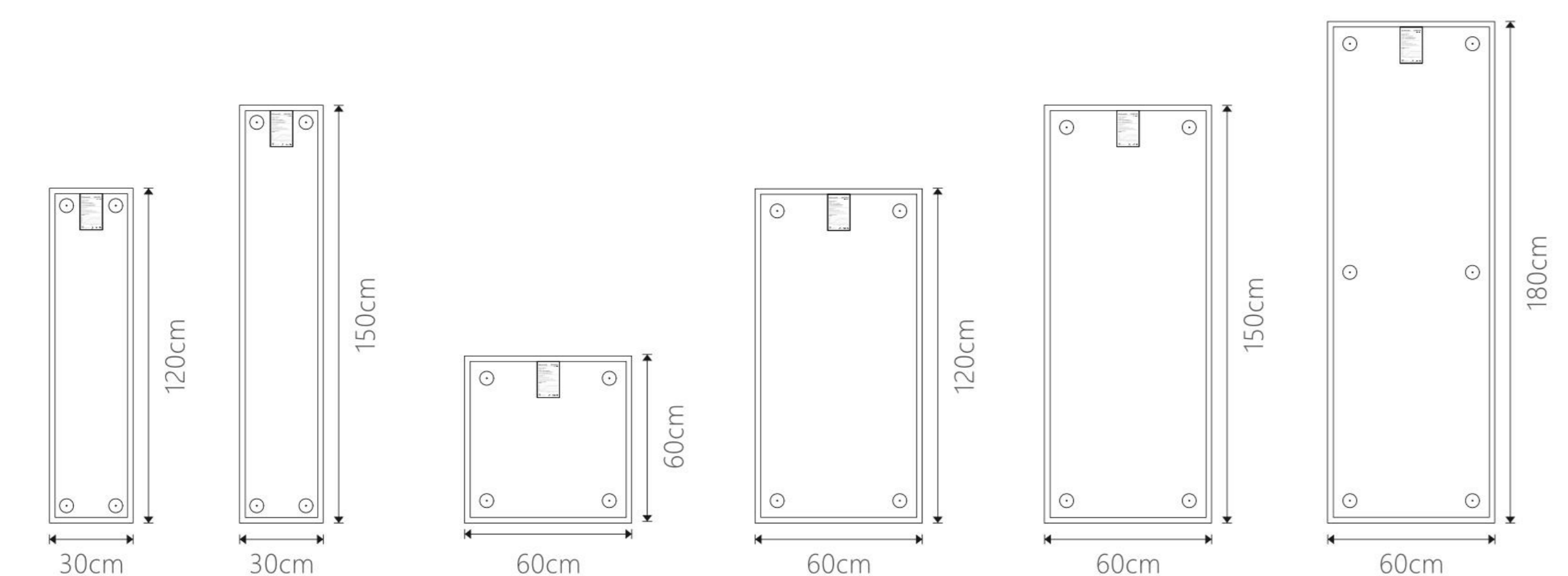

Installation diagram

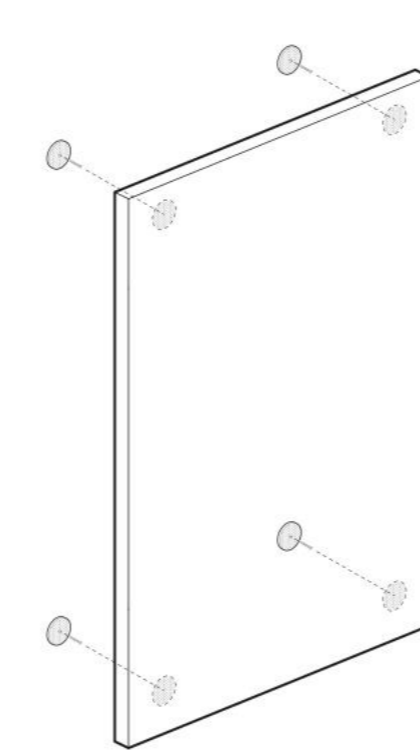

Wall mounting installation diagram

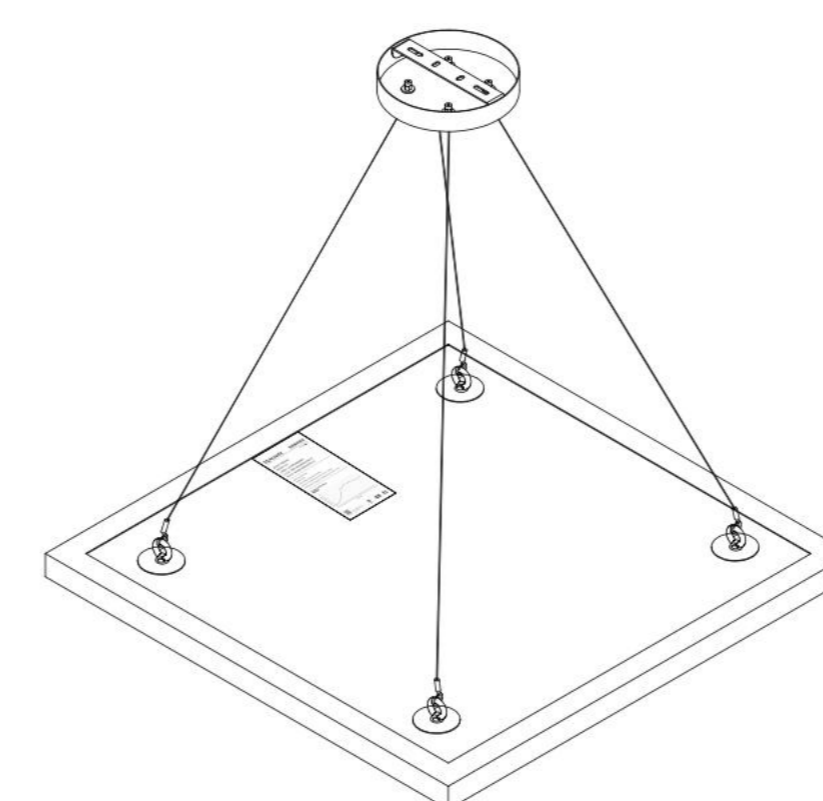

Hanging installation diagram



Reference

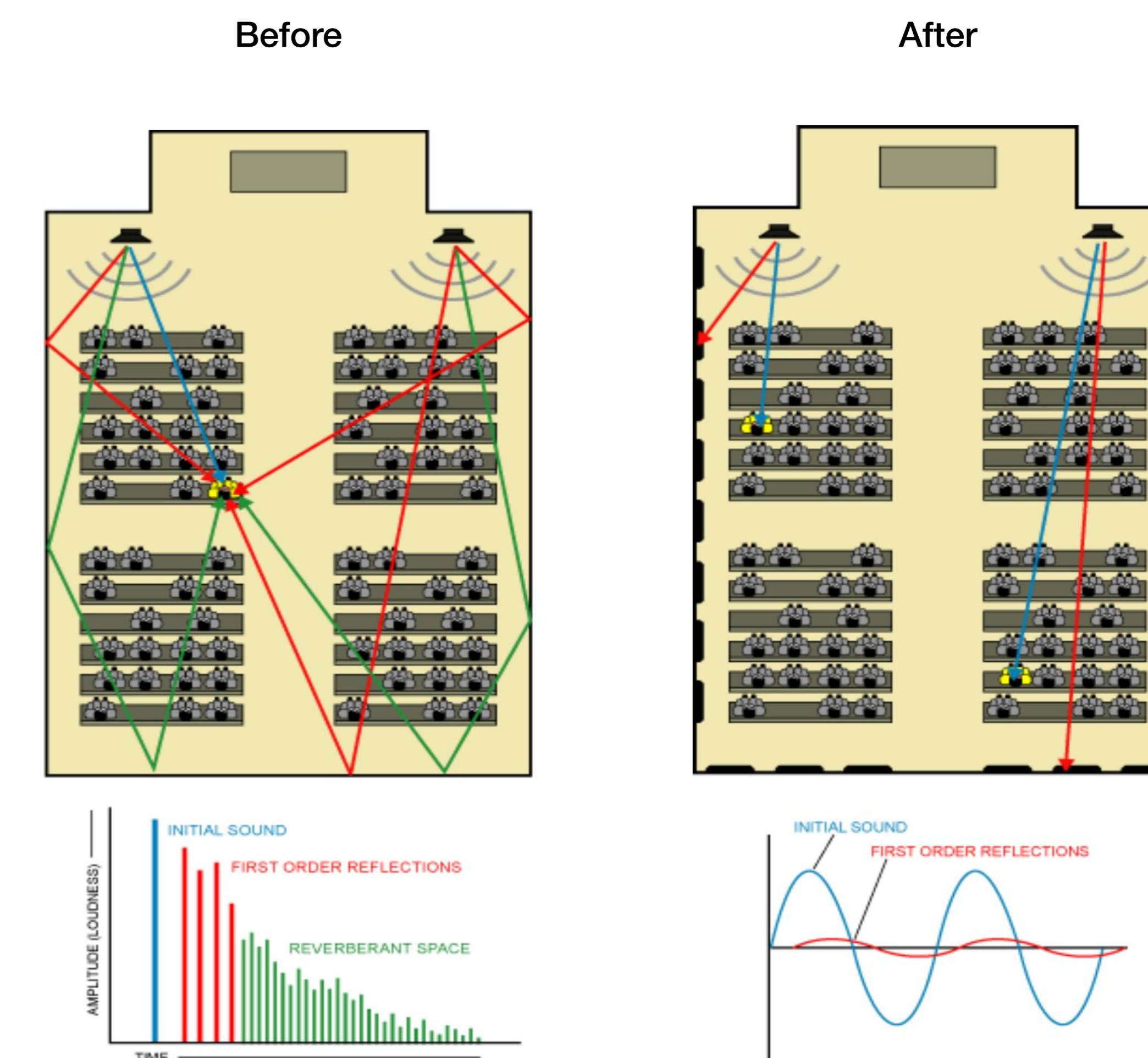
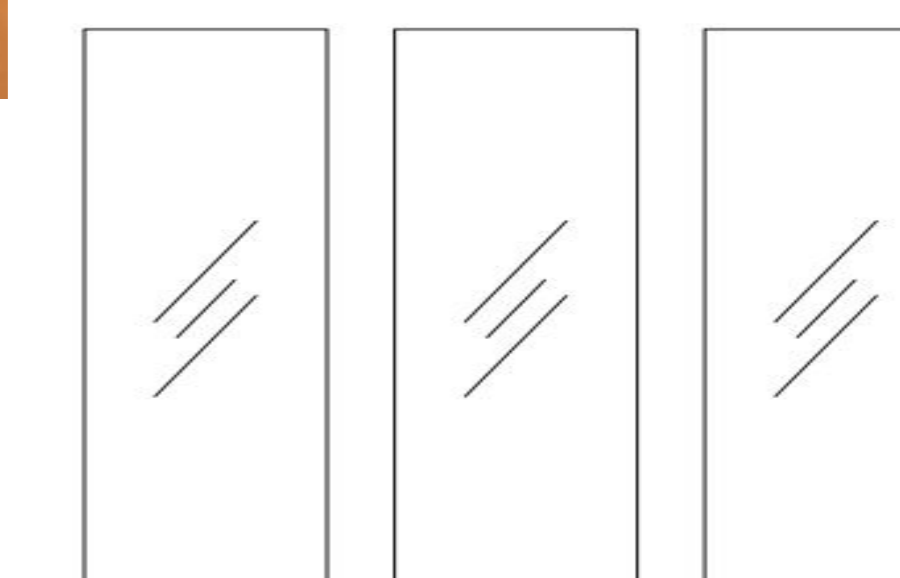



Name: Rococo

Models: EQ50R

Base Material: eco-friendly composite acoustic wool of different density

Finish: SF, UA, YC fabric acoustic cloth surface finishing

Eco-Friendly: Zero Formaldehyde emission, Enf standard

Weight: ~ 5 Kg /m²

Easy to install acoustic treatment solution that effectively controls the largest primary reflection in sound waves.

Using high-density natural micro-porous cotton fiber combined with the huge absorption surface area of the broadband tuning plate, it can effectively improve the sound superposition of reverberation and excessive echo generated by a large sound pressure level.

The Rococo style first appeared in decorative arts and interior design. it reflects the intertwined atmosphere of social pleasure, luxury and love. Our product are designed with a deep respect for architectural design, geometrical shaping and aesthetic factor. Placing them in a room will eliminate fluttering echo and standing waves, while preserving beneficial reflection through scattering avoiding over absorption and keeping the sense of fullness and space.

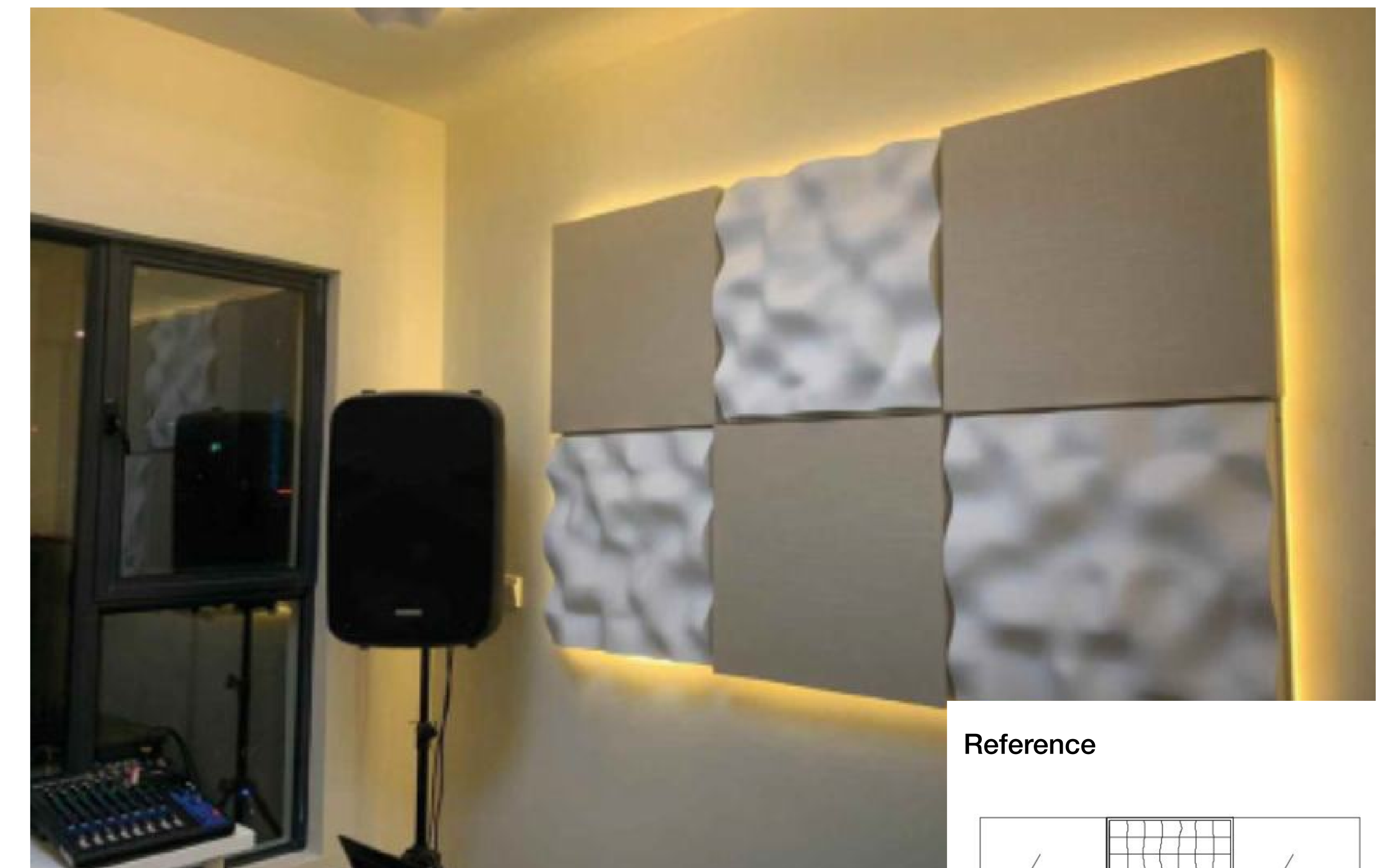
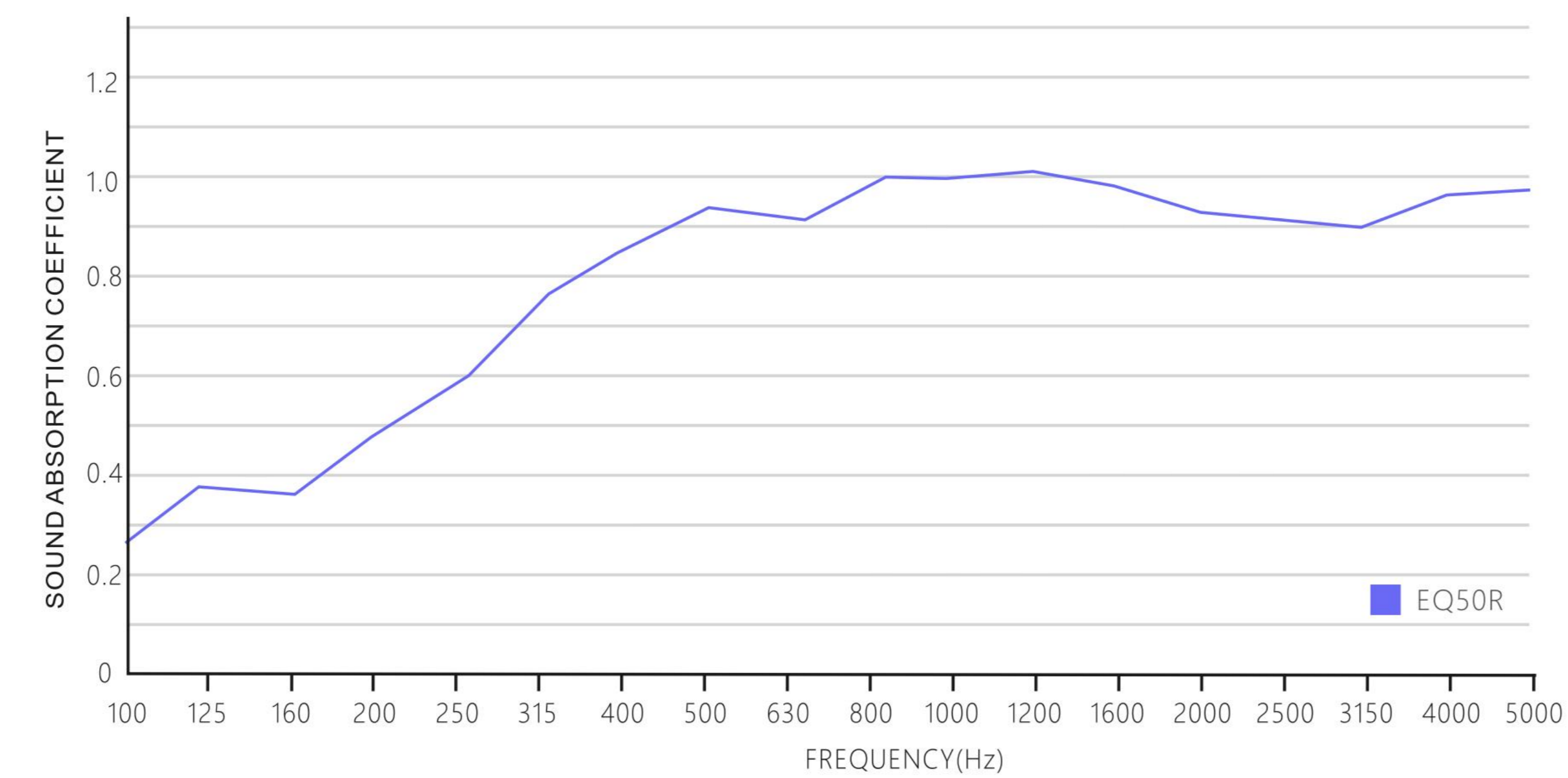

Reference

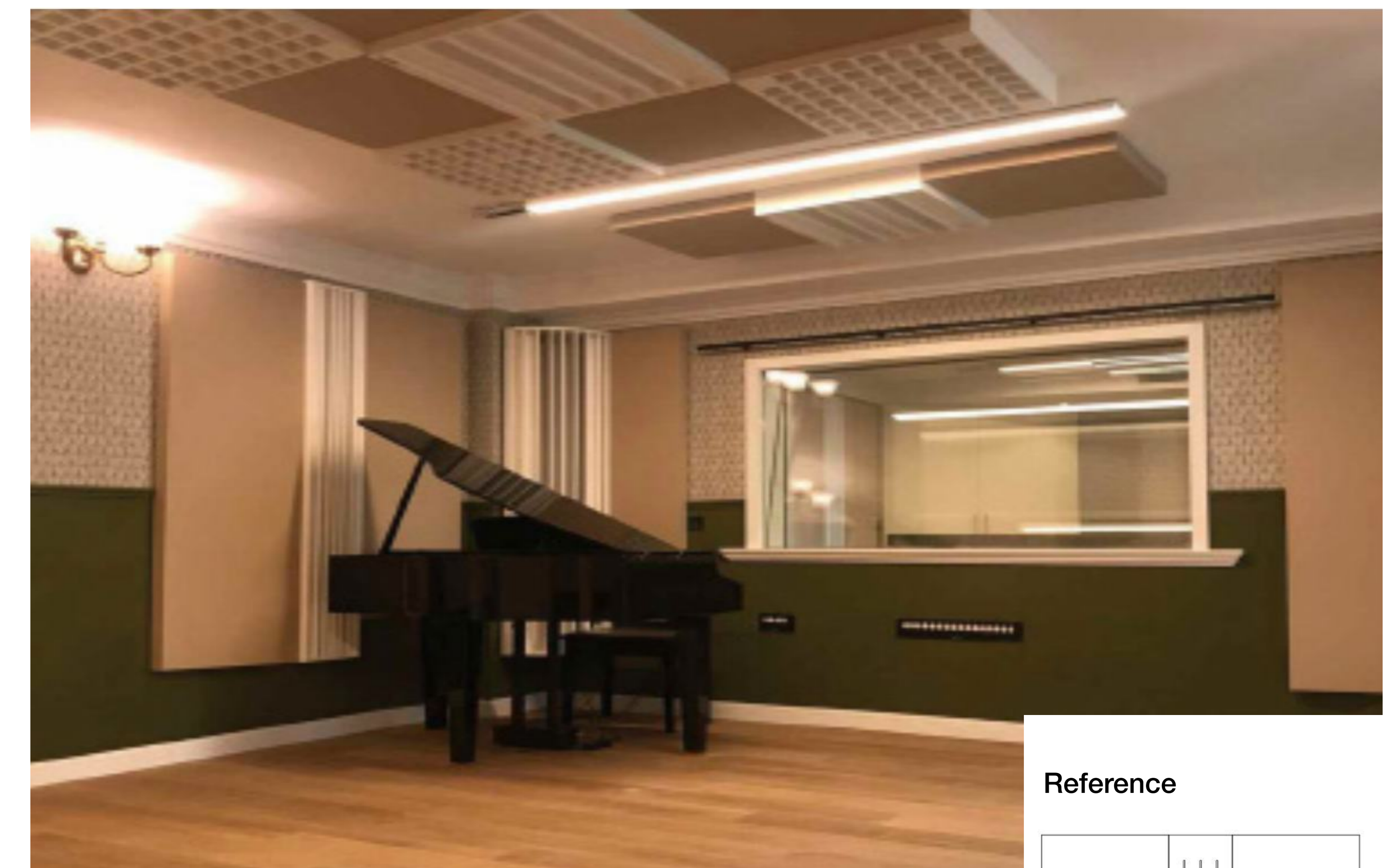
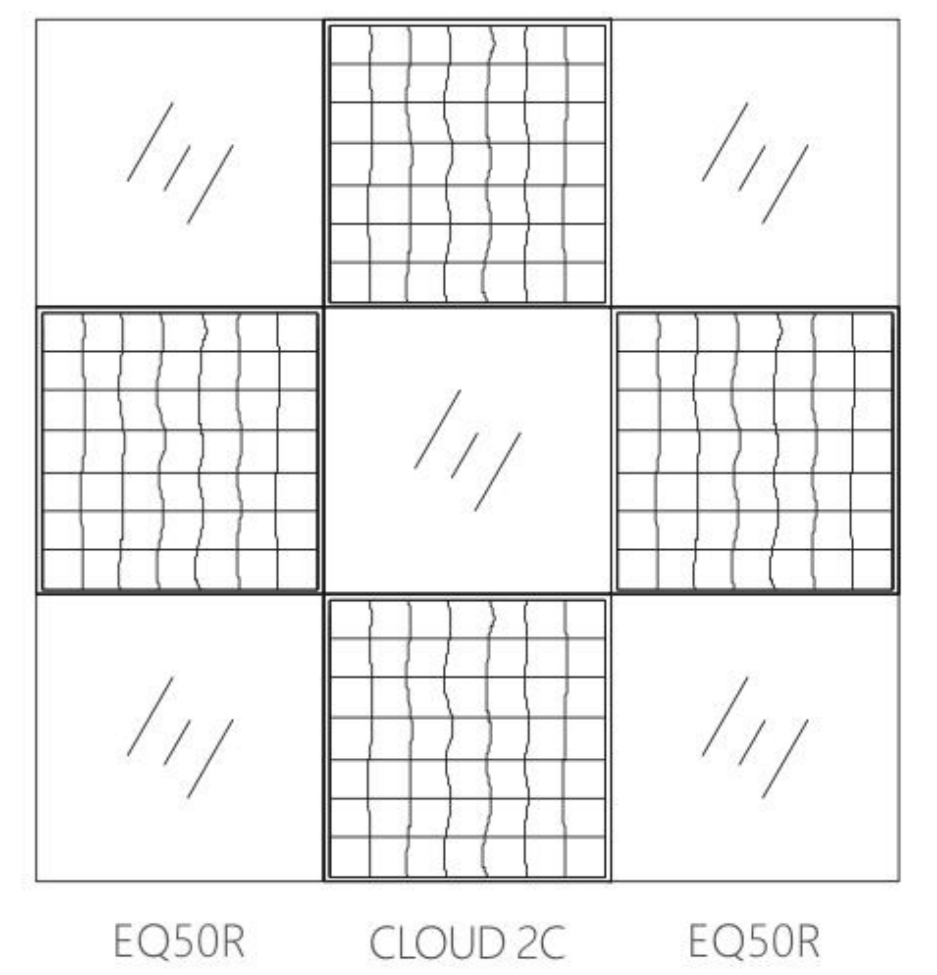

Reference

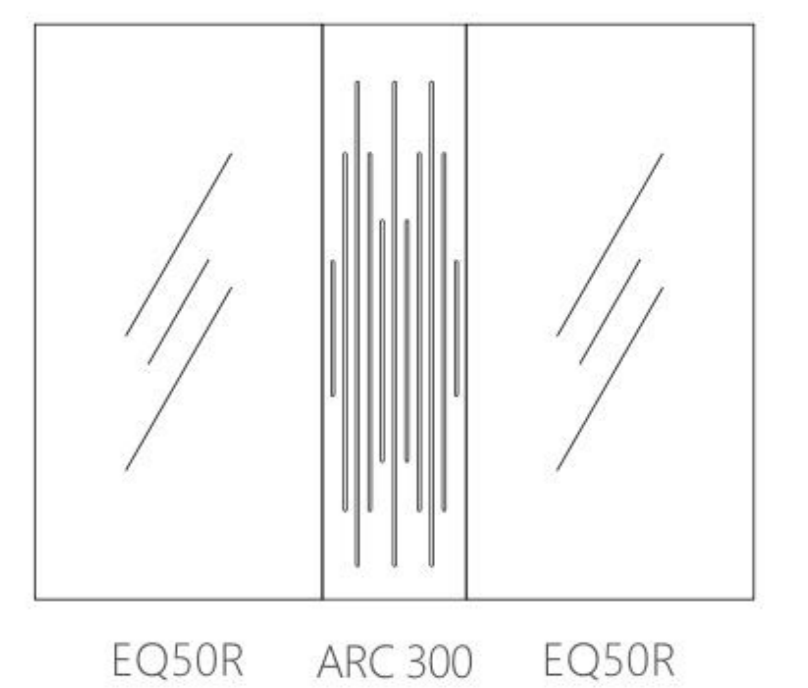

Size

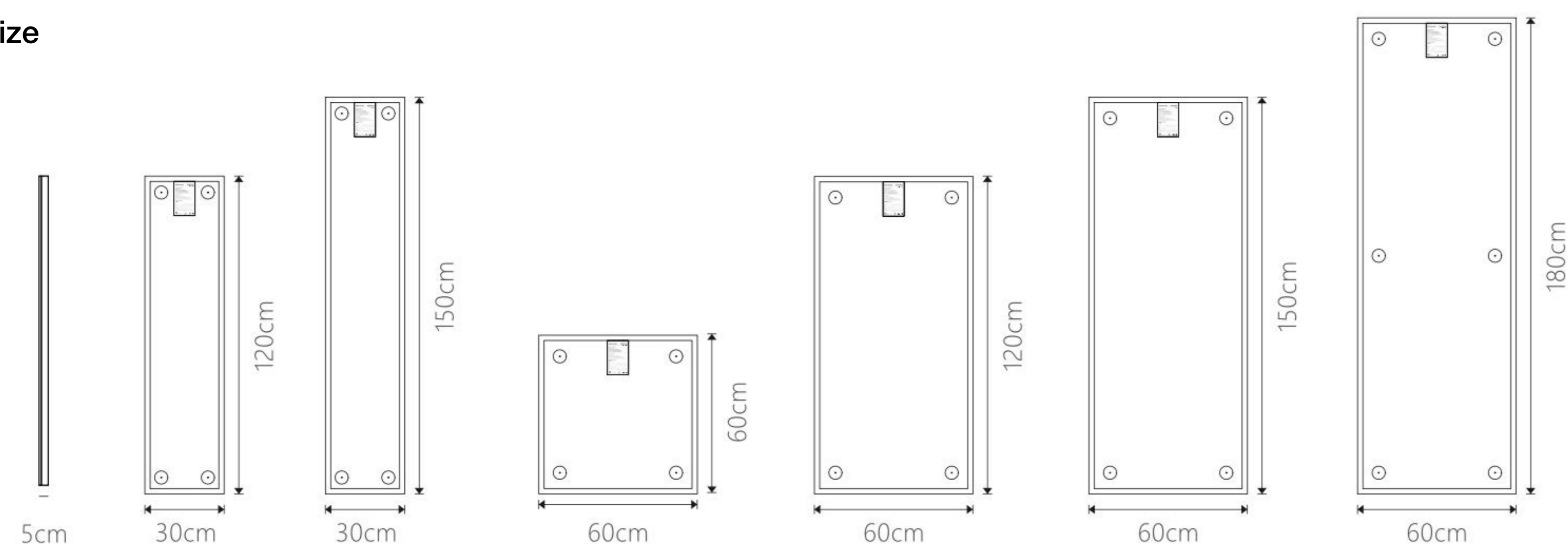

Installation diagram

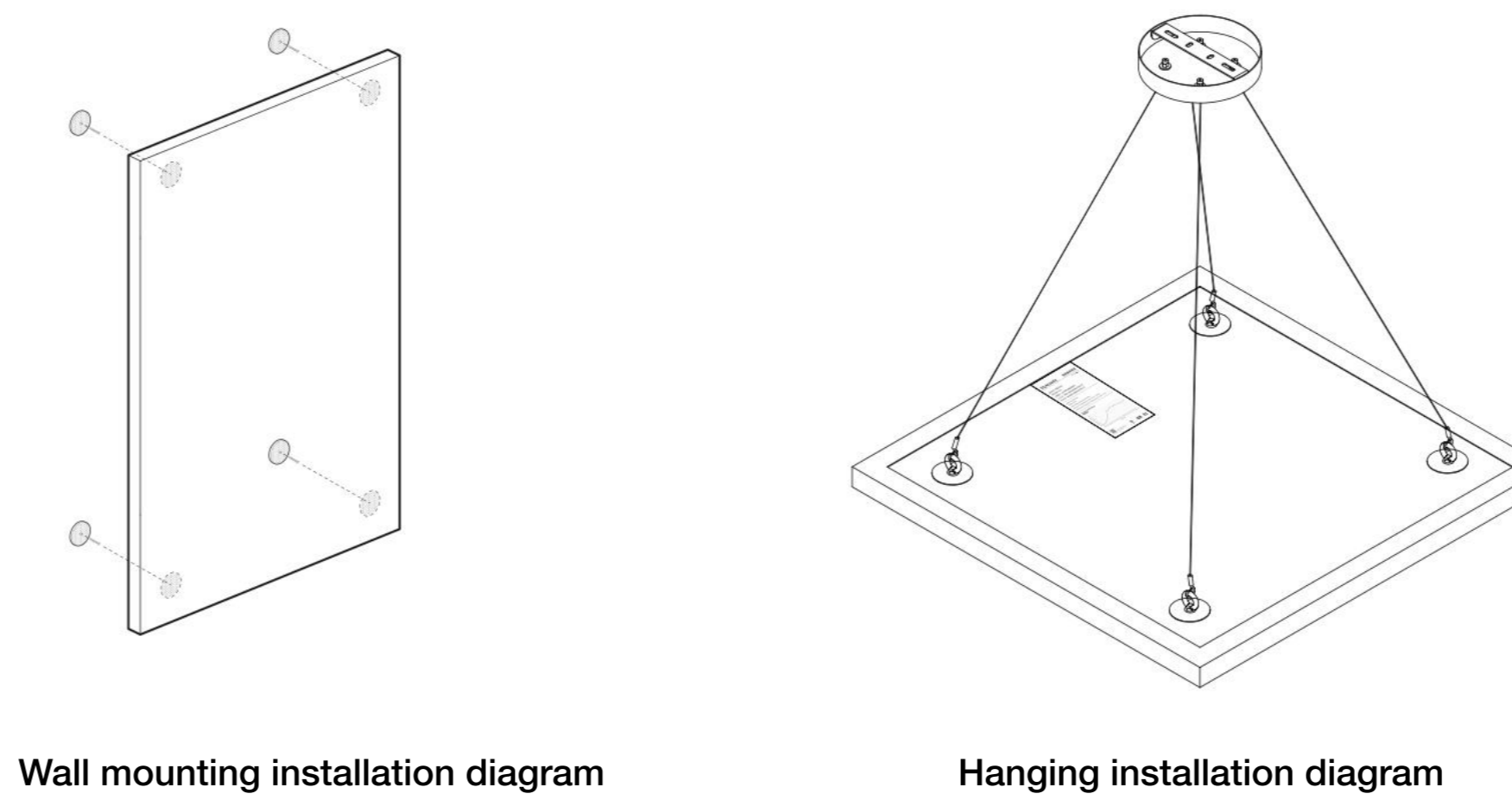

Wall mounting installation diagram

Hanging installation diagram



Name: Baroque

Models: EQ50B

Base Material: 100% eco-friendly acoustic composite fiber wool

Finish: SF, YC fabric acoustic cloth surface finishing

Eco-Friendly: Zero Formaldehyde emission, Enf standard

Weight: ~ 5 Kg /m²

Integrated mixed density acoustic linen and high density porous green wool in an airtight structure along with its modular design makes this product suitable for tuning the broadband frequency in large spaces.

With its highly effective absorption capability and 3D absorbing structure it will transform your listening experience to a natural hall impression.

The Baroque style is full of luxurious decoration and grace temperament providing an open and passionate living atmosphere.

Placing it in a room will eliminate fluttering echo and standing waves, while preserving beneficial reflection through scattering avoiding over absorption and keeping the sense of fullness and space.

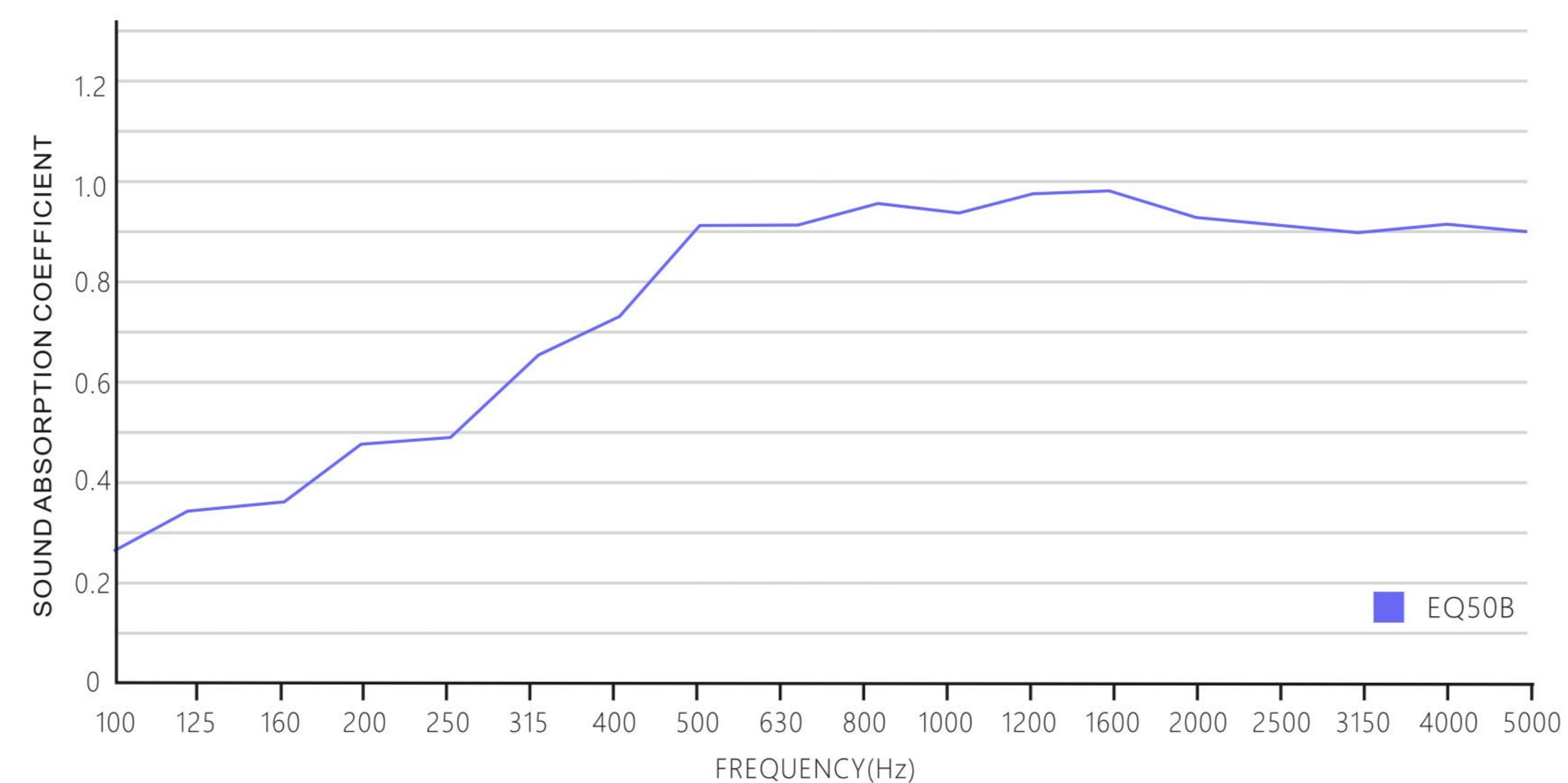

Size

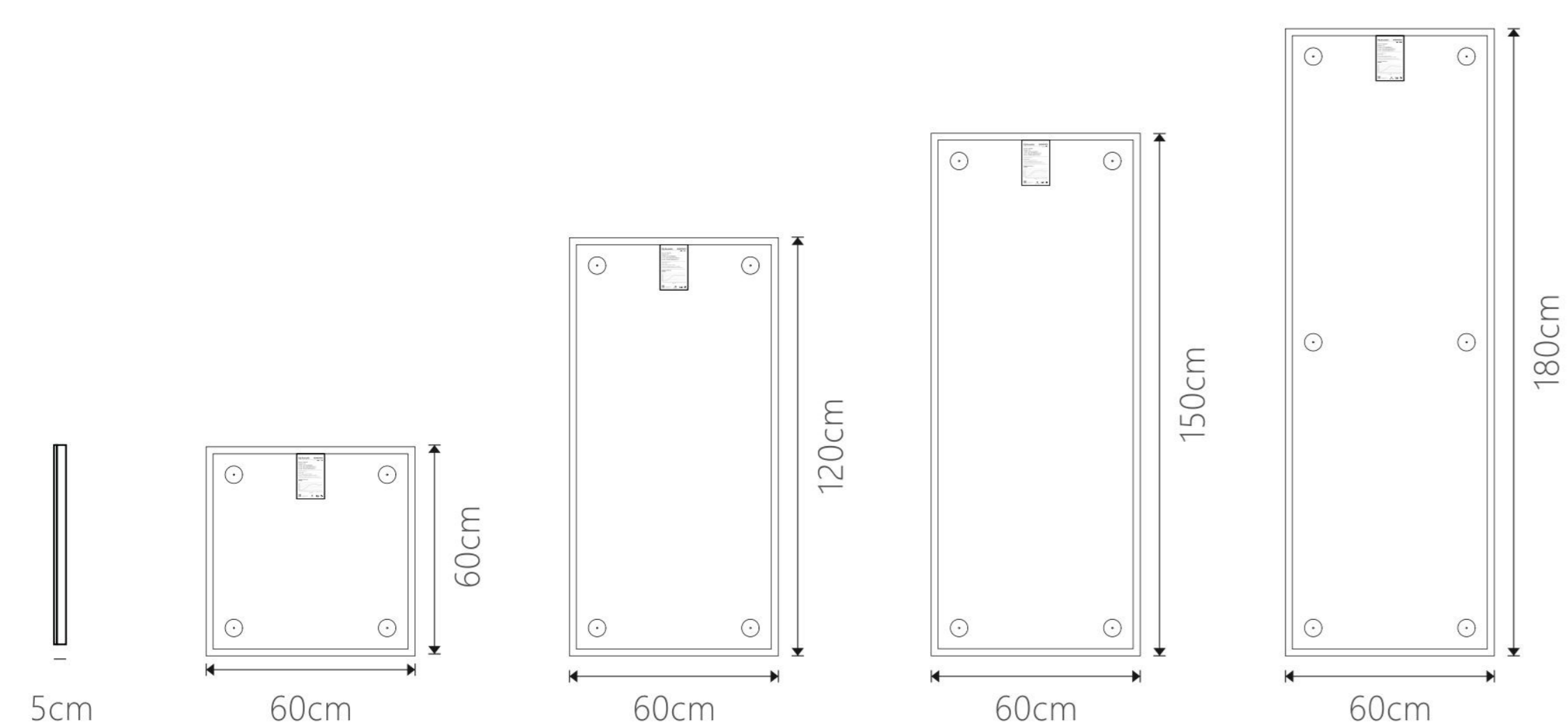

Installation diagram

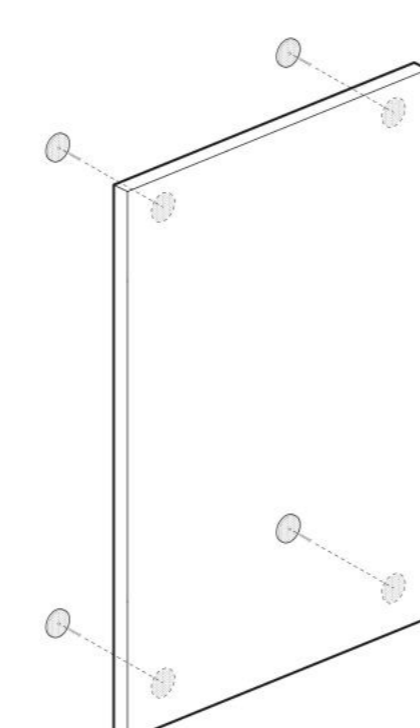

Wall mounting installation diagram



Reference

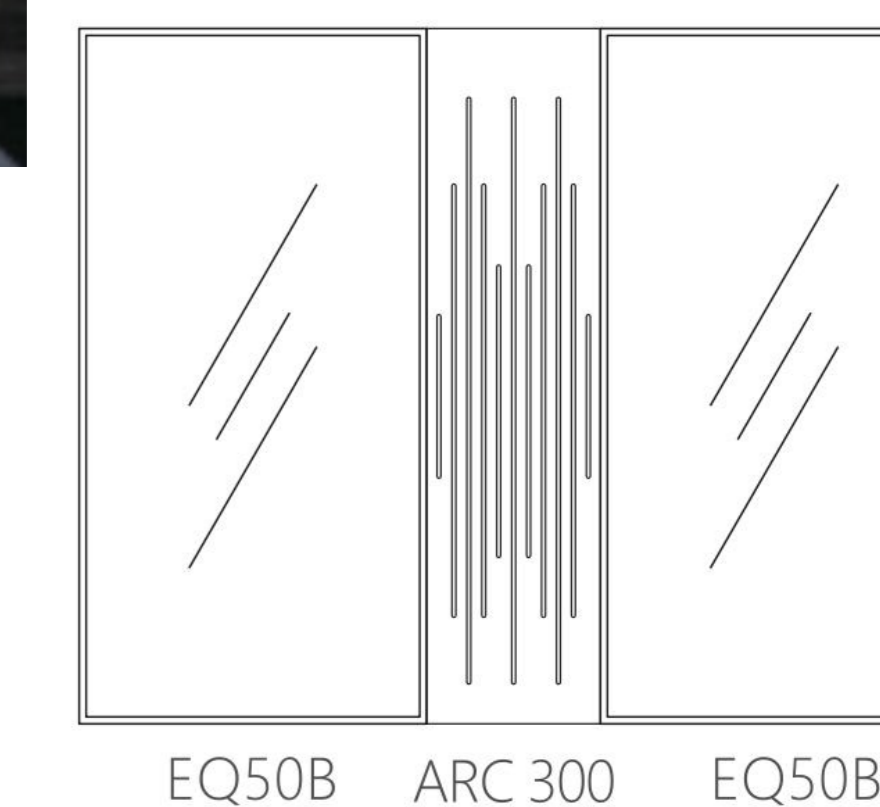

Reference

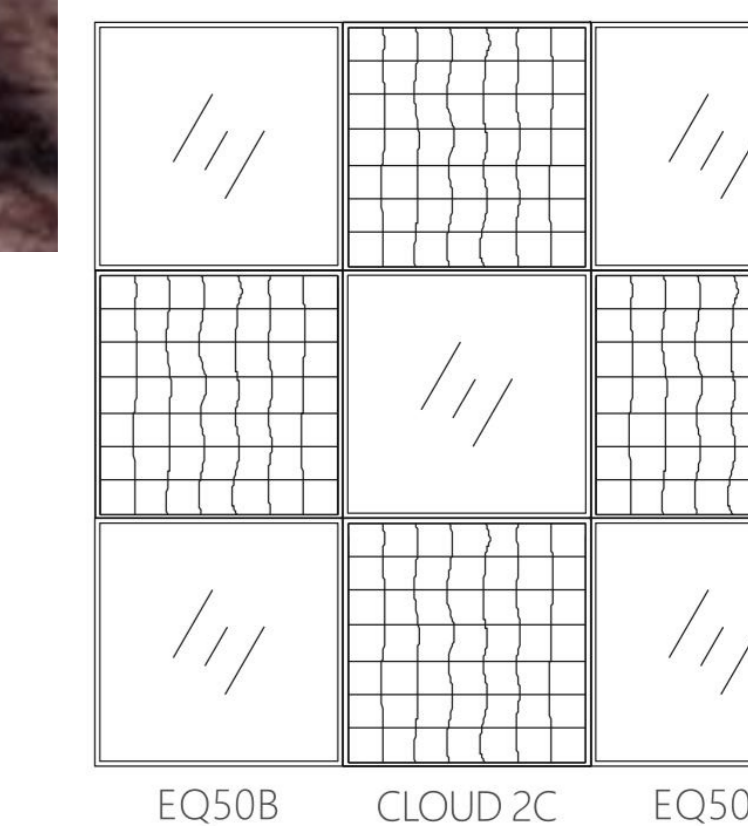



Name: Versailles
Models: EQ50Q
Base Material: Purely natural green fiber acoustic wool
Finish: SF, YC fabric acoustic cloth surface finishing
Eco-Friendly: Zero Formaldehyde emission, Enf standard
Weight: ~ 5 Kg /m²

Excellent acoustic characteristics combined with art, technology and standard size or customized, integrates this product easily into the space. Its customization option allows setting up a balanced absorbing in any space and for every designation.

Versailles units are finished with random crack convex surface, which forms plenty different absorbent angles to eliminate broader frequency spots, medium frequency fluttering echoes and low frequency standing waves, controlling the reactivation between sound reflection source and the listener.

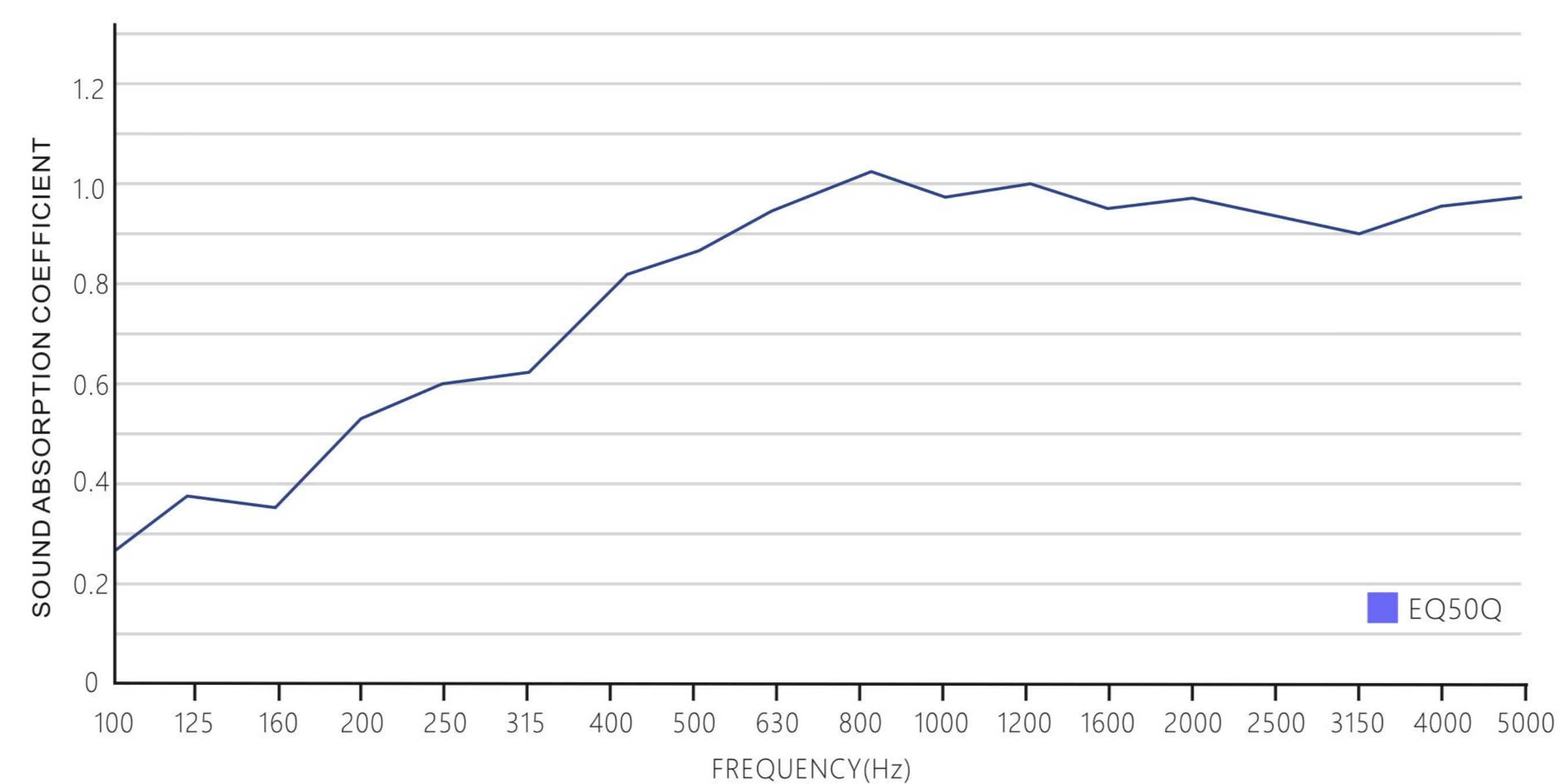
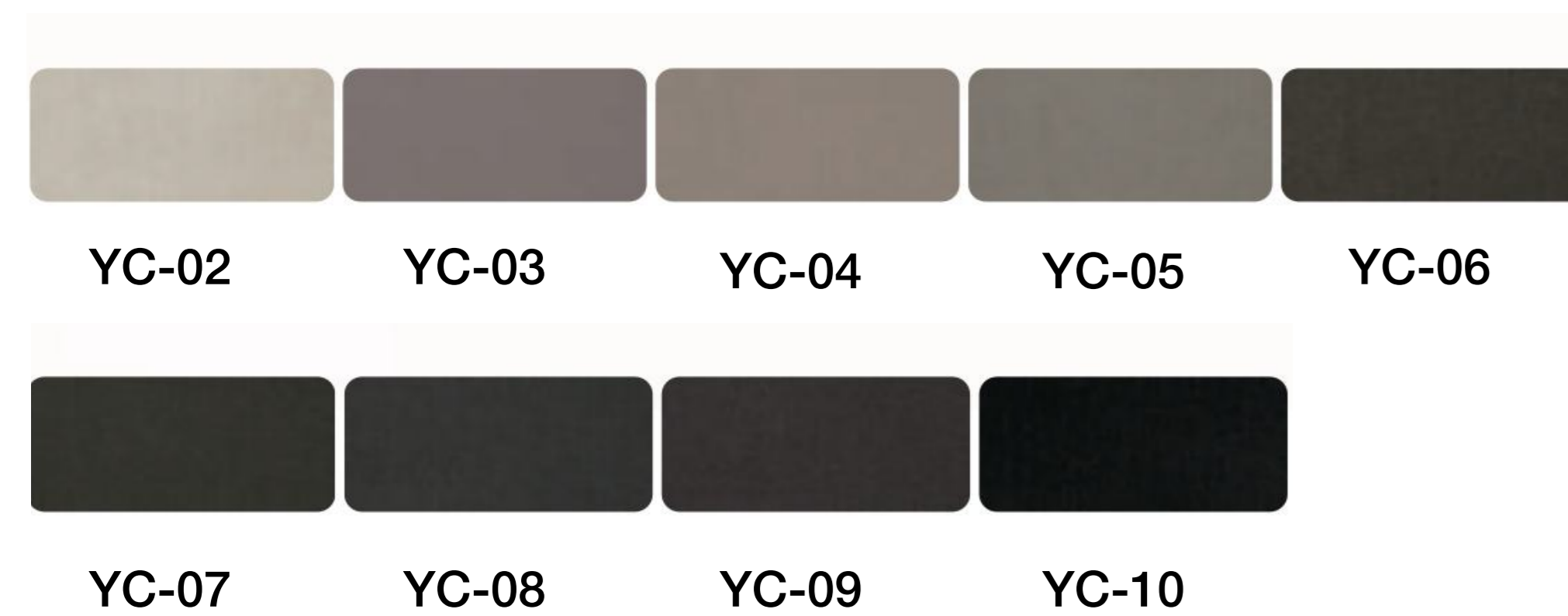

Size

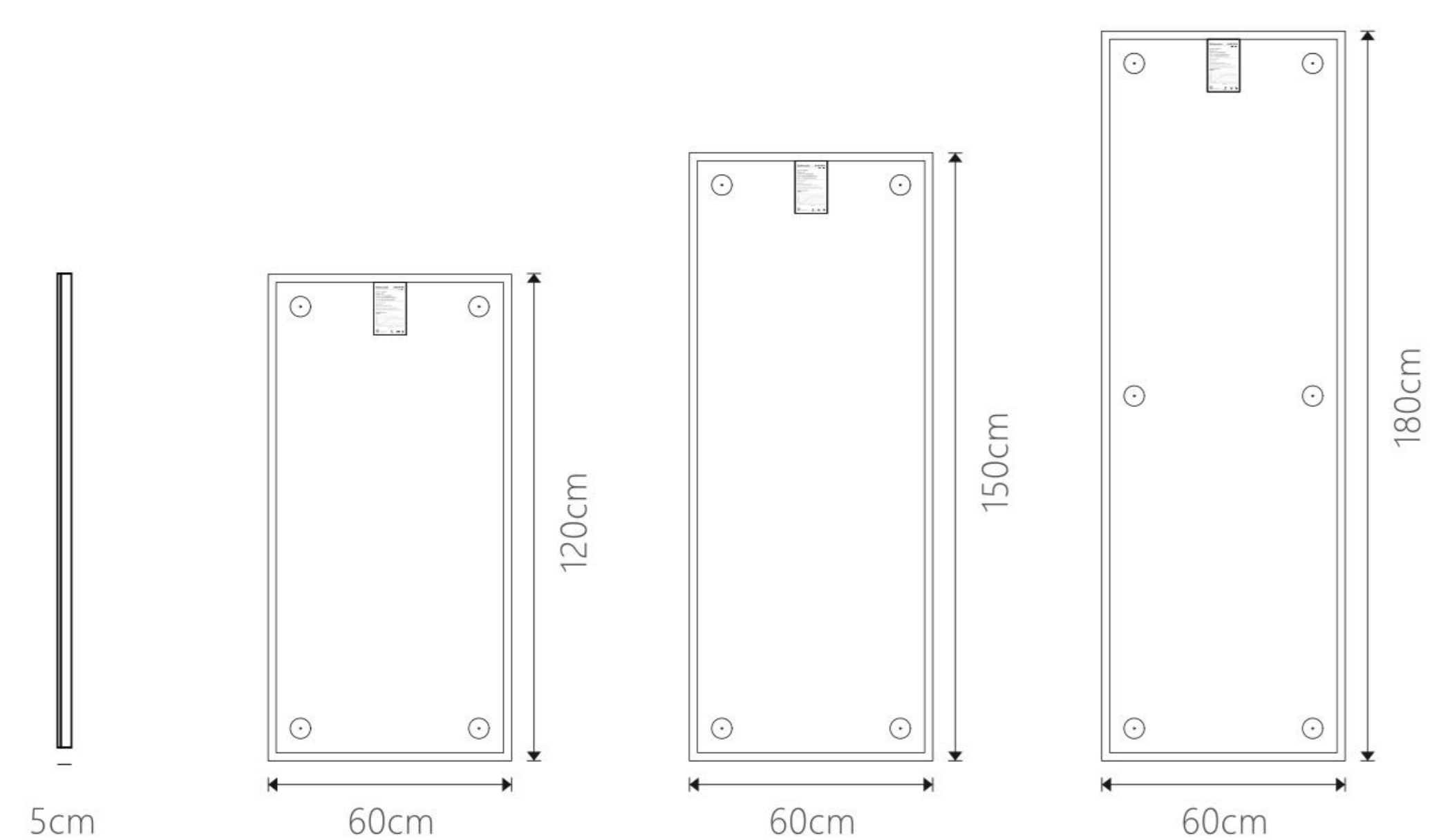

Installation diagram

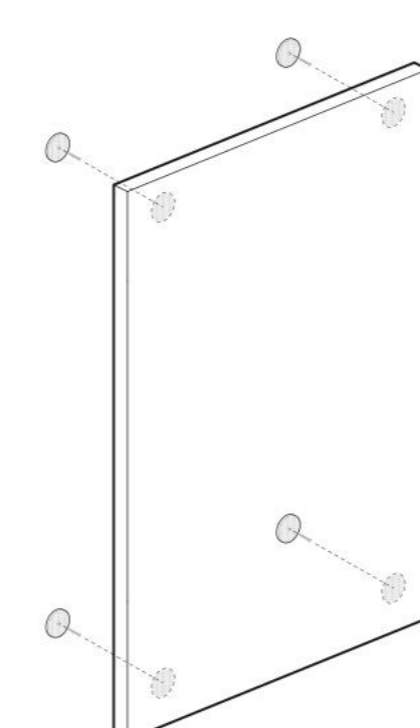

Wall mounting installation diagram



Reference

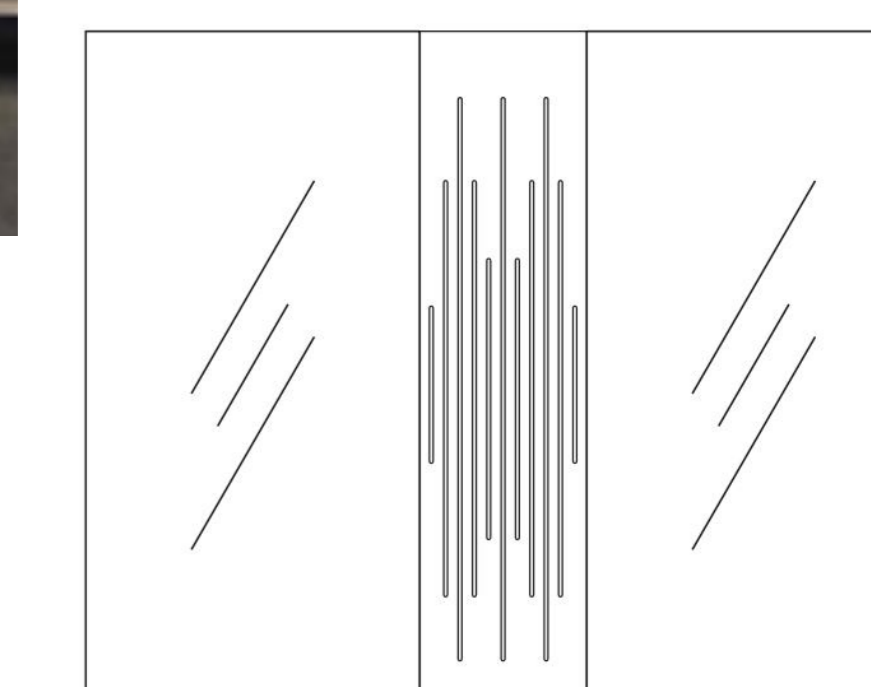

EQ50Q ARC 300 EQ50Q

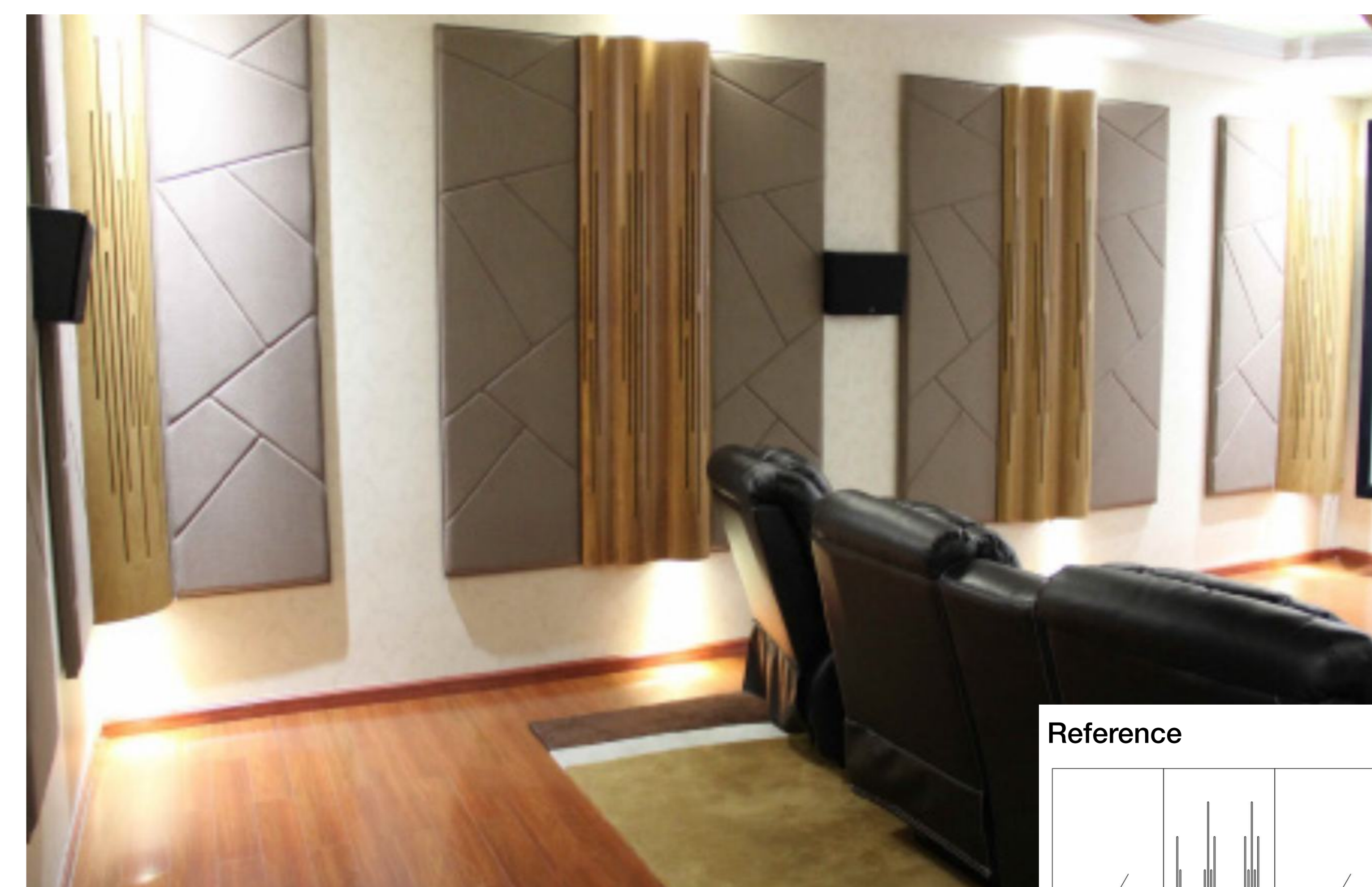

Reference

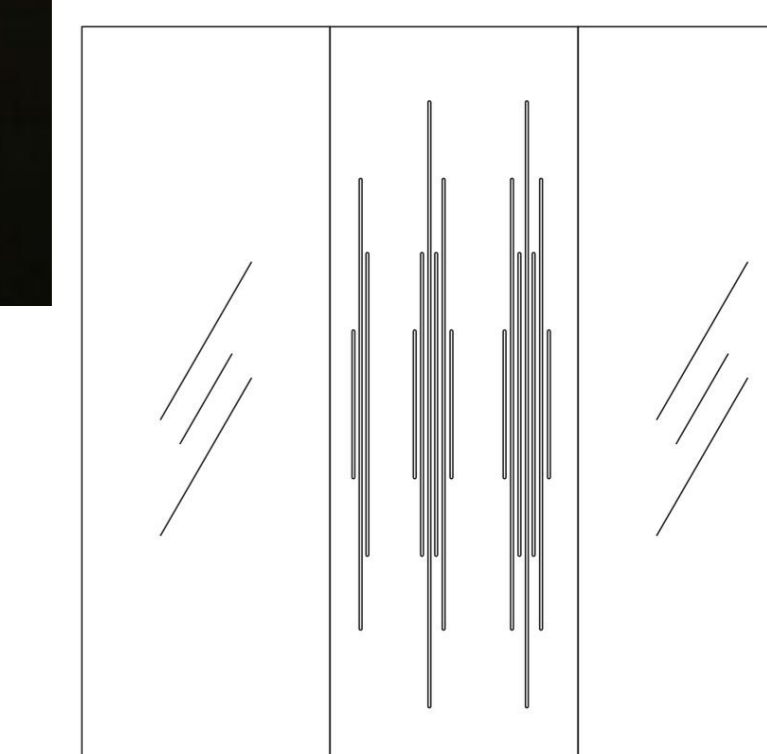

EQ50Q WAVE 600 EQ50Q



Name: Mirage

Models: EQ2.1 / EQ2.2 / EQ2.3 / EQ2.4(Plus)

Base Material: Purely natural green fiber acoustic wool

Finish: SF, UA, 14 series, fabric acoustic cloth surface finishing

Eco-Friendly: Zero Formaldehyde emission, Enf standard

Weight: ~ 6.3Kg /m²

This four layer, non-equivalent density composite base material, is conducive to enhancing sound energy absorption in a wider frequency band.

Its flat soft surface is the perfect for hard walls and can effectively prevent sound reflection and reduce reverberation time.

The product's unique closed acoustic cavity is designed to increase the absorption of low-frequency residual sound energy, along with its aluminum frame structure the result is maximum absorption surface area and acoustic performance.

Application: Office, Conference room, reception space, leisure room, home cinema, studio etc.

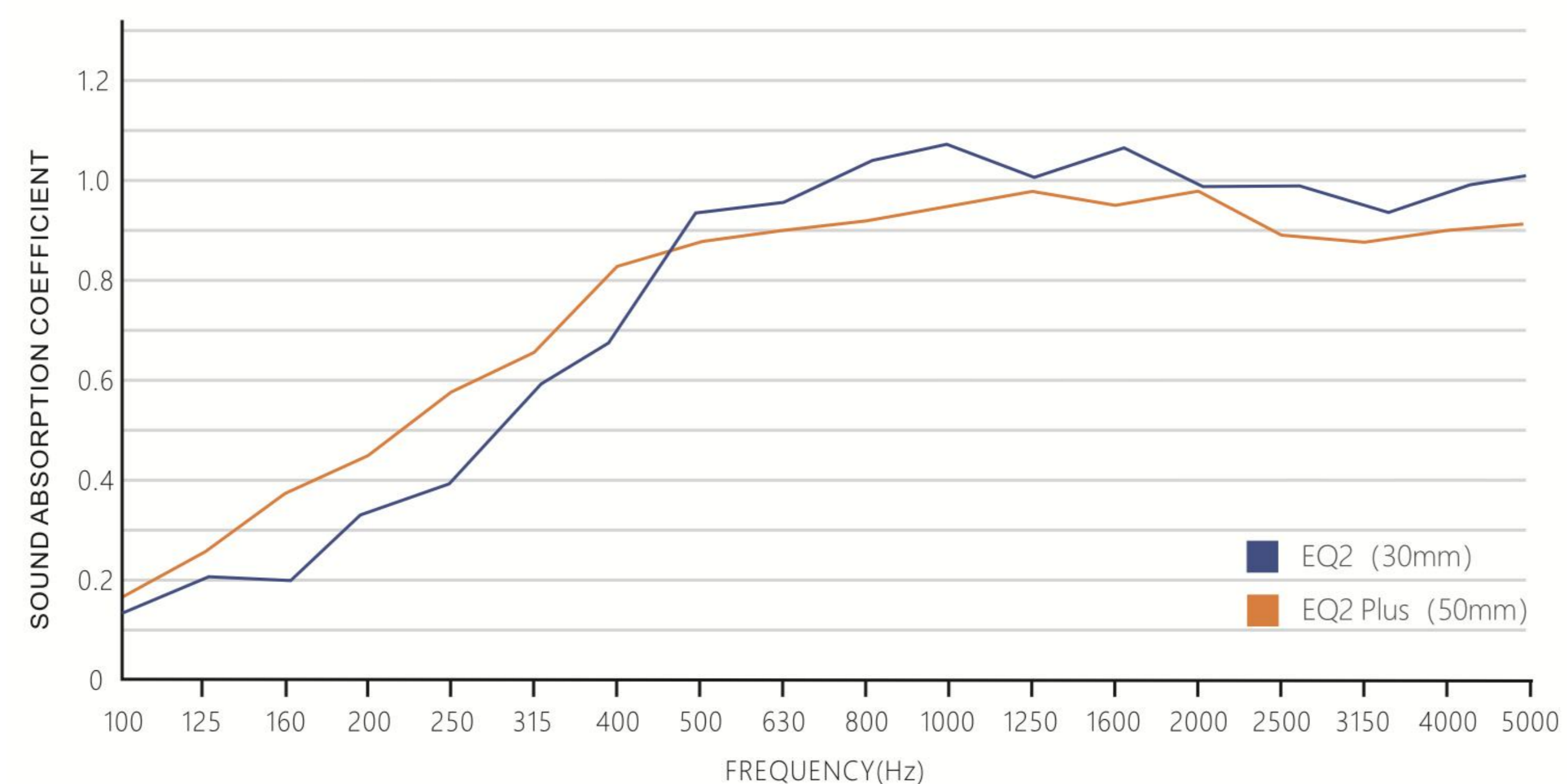

Size

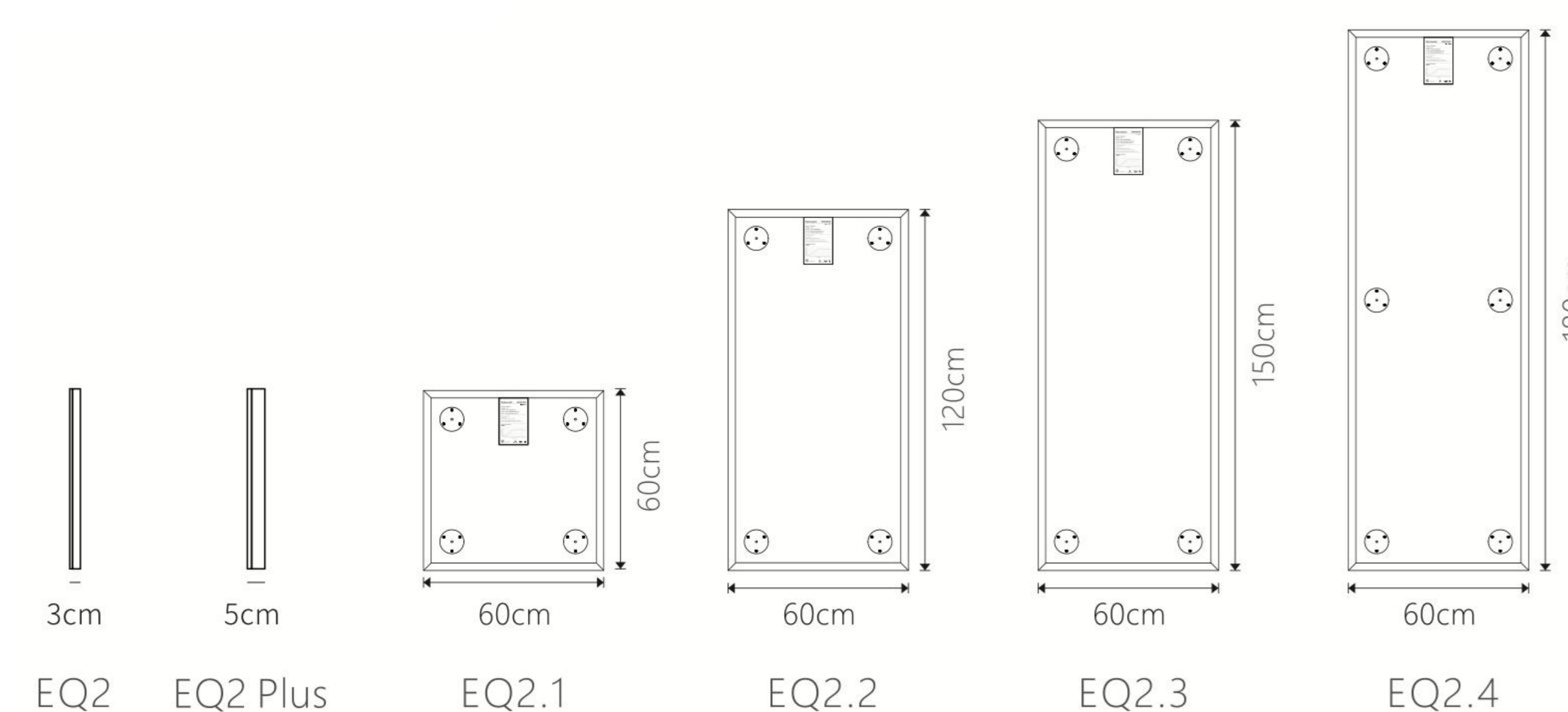

Installation diagram

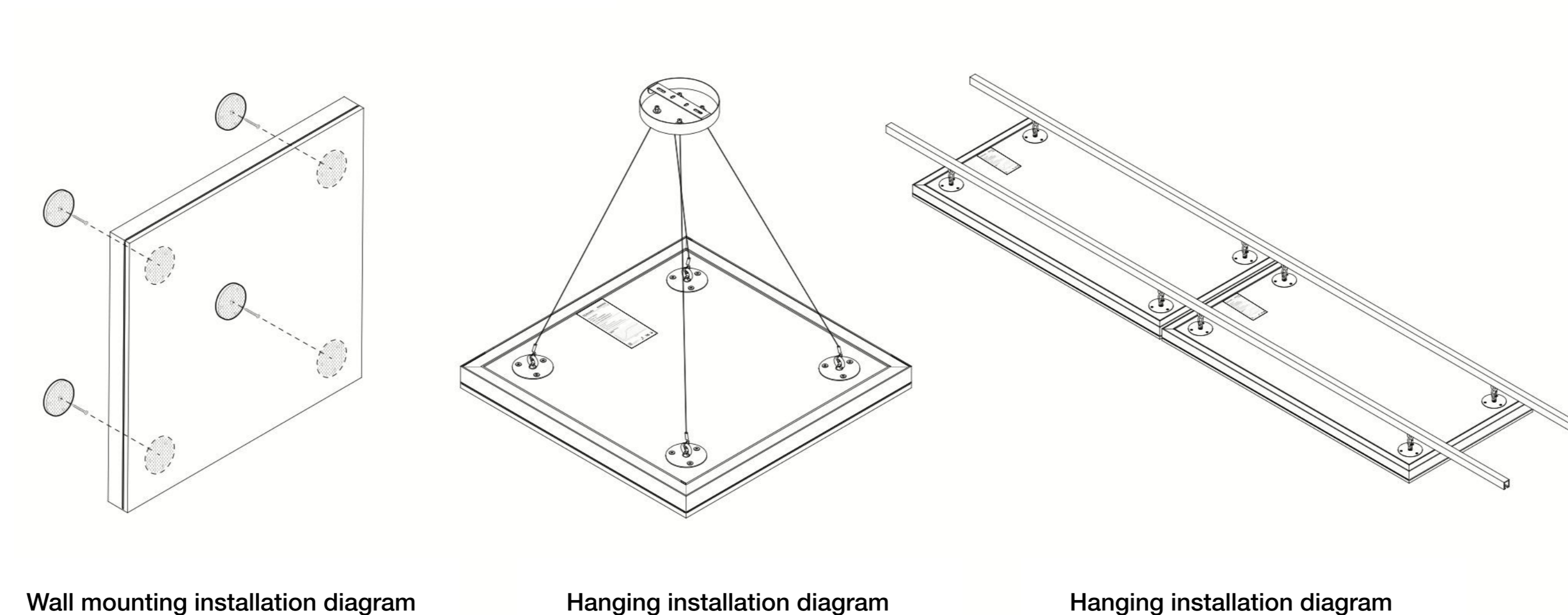

Package

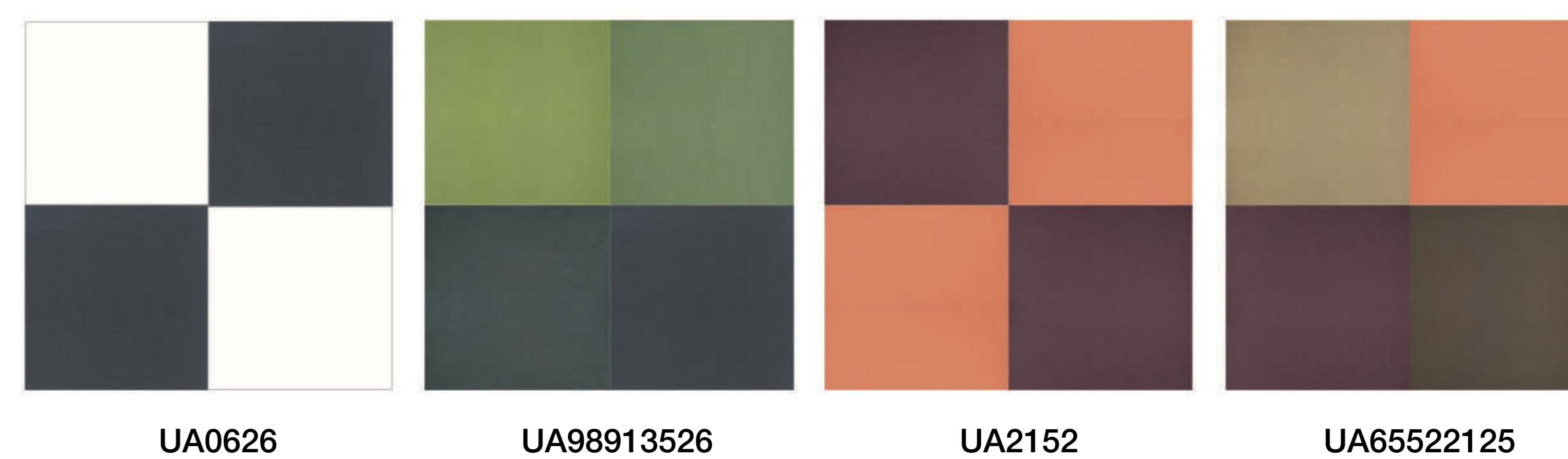
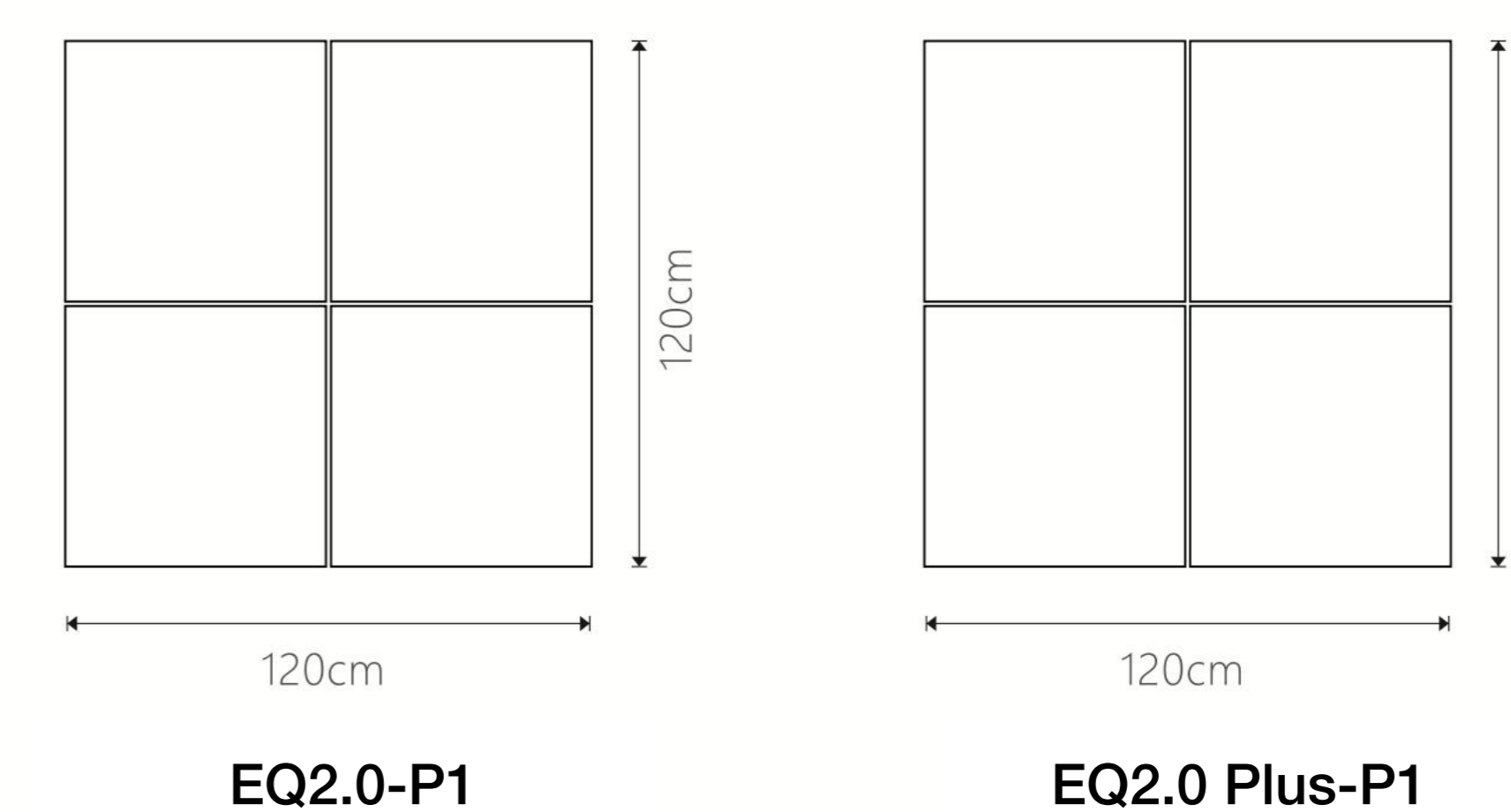



Name: Phantom

Models: EQ3.1 / EQ3.2 / EQ3.3 / EQ3.4

Base Material: Purely natural green fiber acoustic wool

Finish: SF, 14 series, fabric acoustic cloth surface finishing

Eco-Friendly: Zero Formaldehyde emission, Enf standard

Weight: EQ3.1~3.4Kg, EQ3.2~4.7Kg, EQ3.3~5.9Kg, EQ3.4~12Kg

The "Phantom" is a combination of rigorous acoustics and technology aesthetics. Streamlined steel structure, optional side lighting for background ambient light, makes it both functional and a beautiful addition to any space.

Its unique rear acoustic cavity design is built to increase low-medium frequency residual sound energy absorption. It quickly controls the main reflected waves on the wall and improves the language intelligibility effectively.

Application: Office, Conference room, reception space, leisure room, home cinema, studio etc.

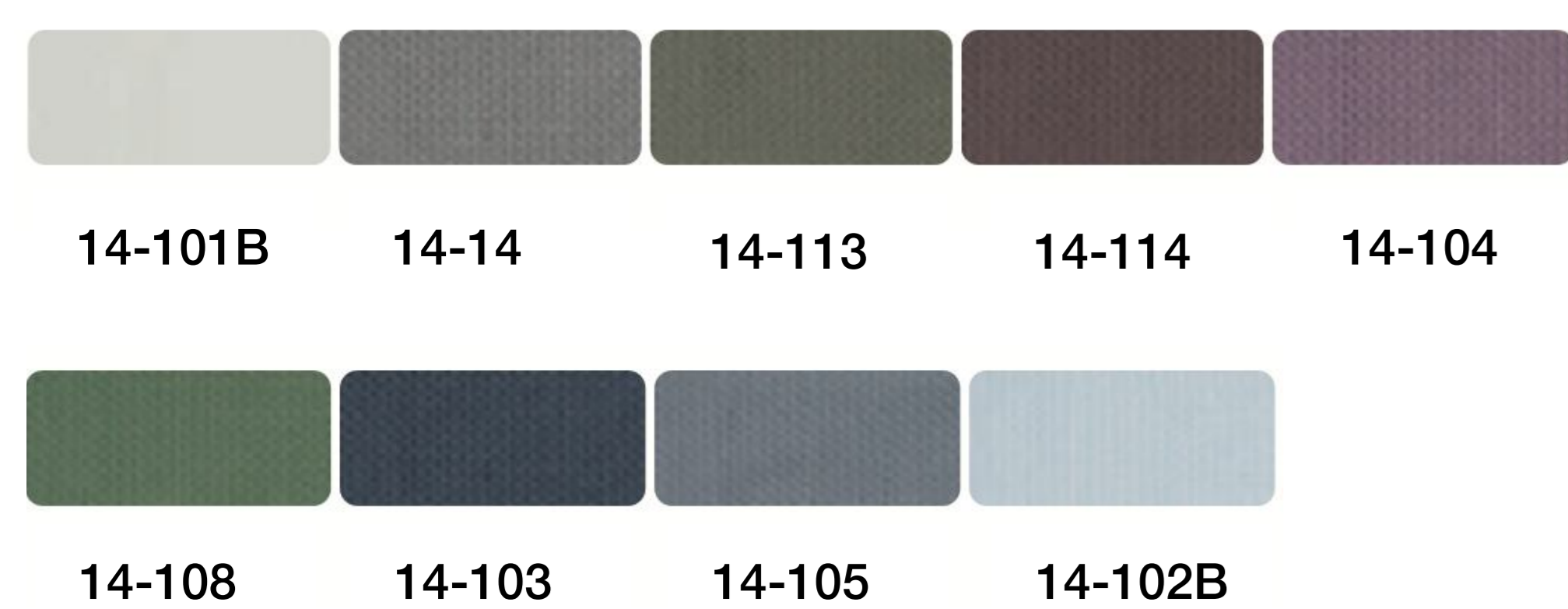
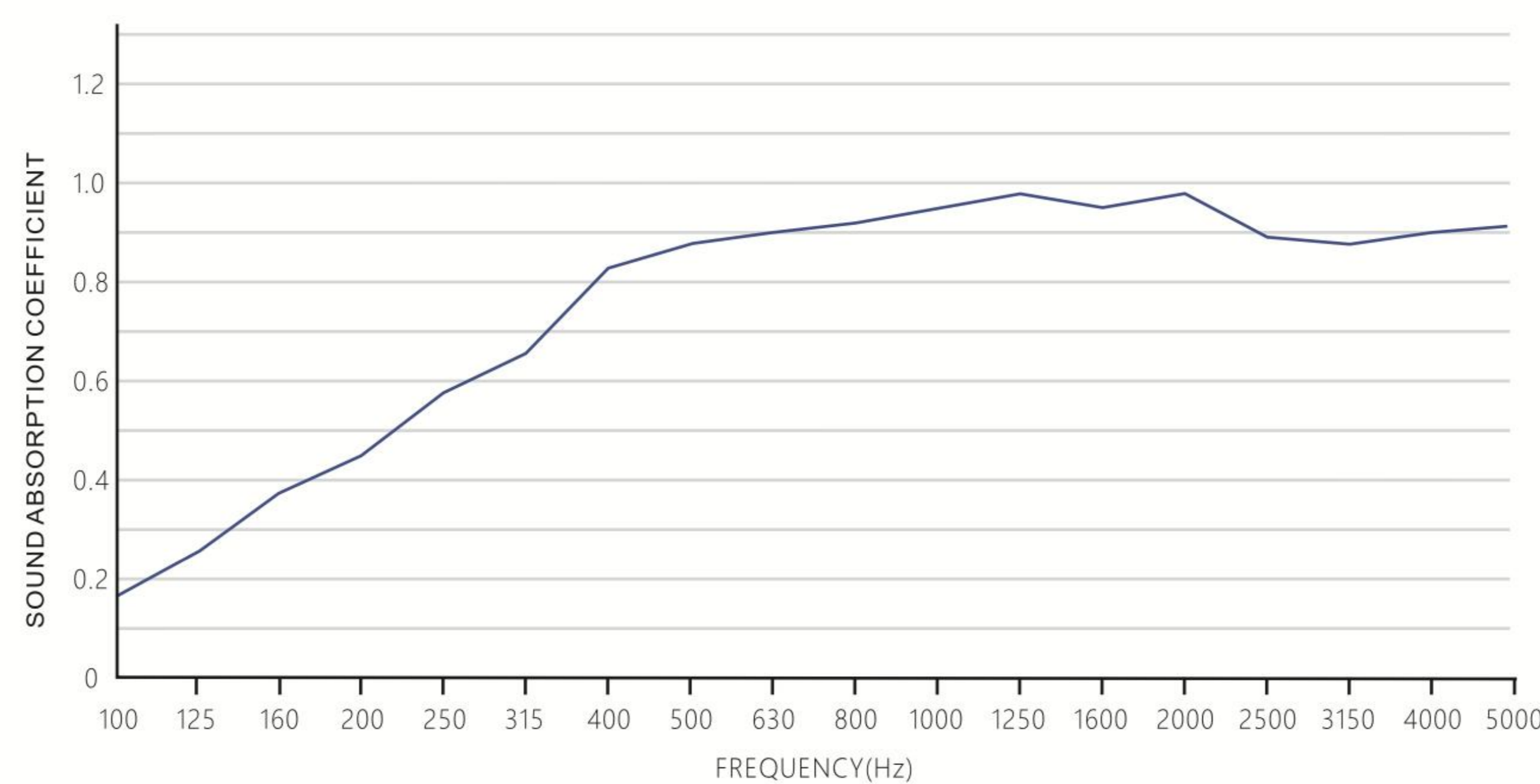

Installation diagram

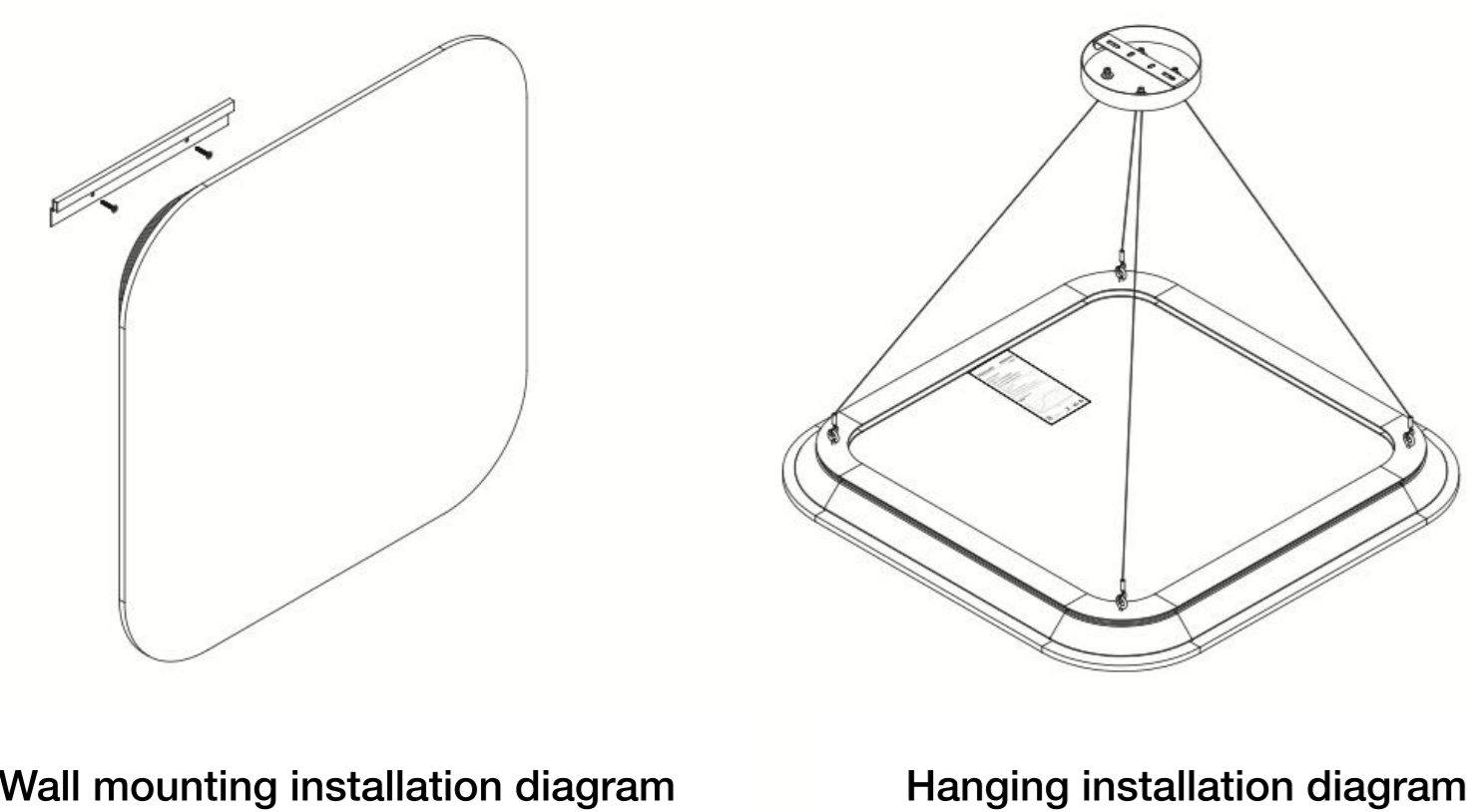

Package

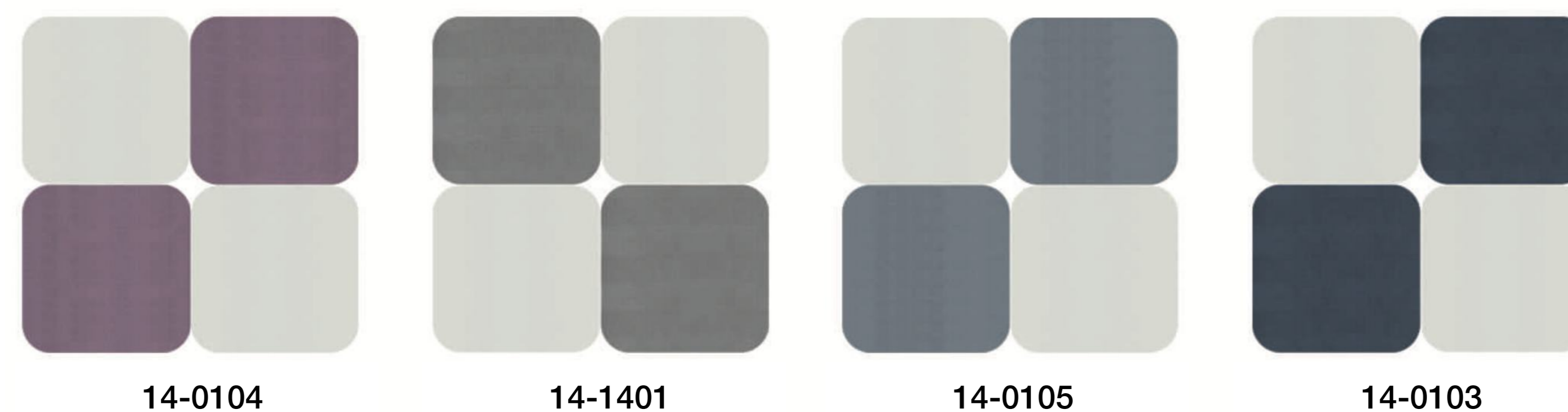
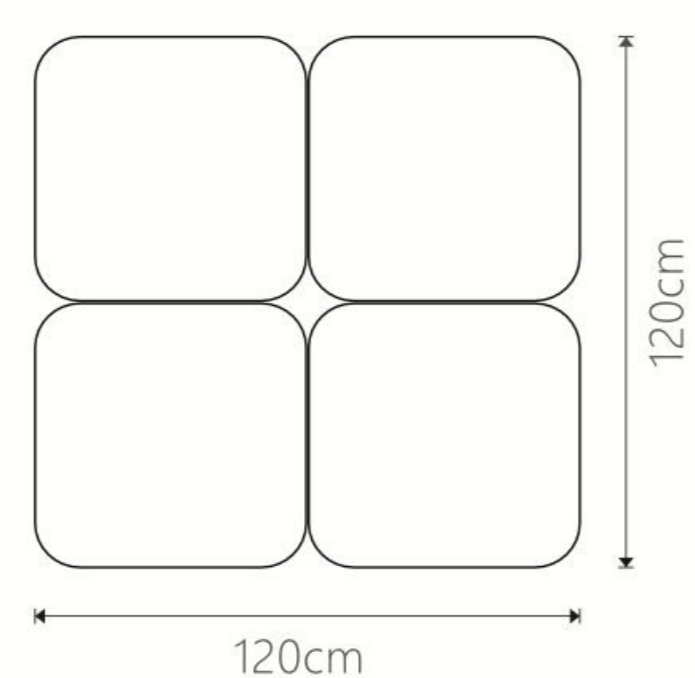

Size





SF-1200 SF-1202 SF-1209 SF-1212 SF-1217



SF-1233 SF-1234 SF-1237 SF-1223



Sound absorbing



Noise reduction



Zero emission



Anti-bacteria

Installation diagram

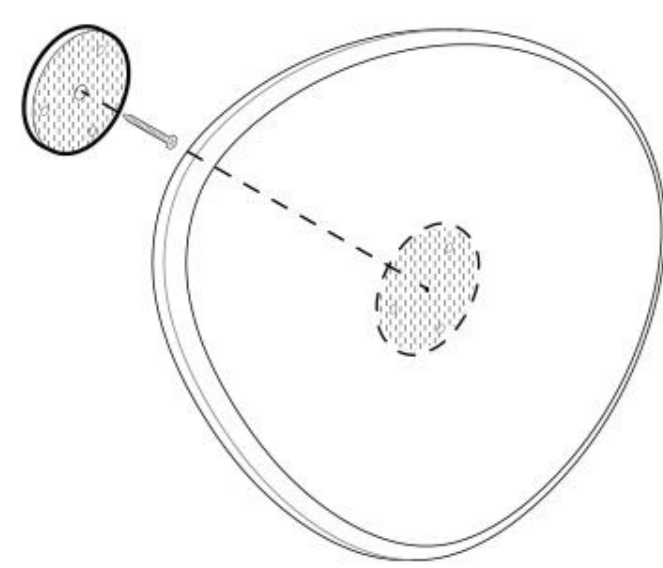

Wall mounting installation diagram

Size

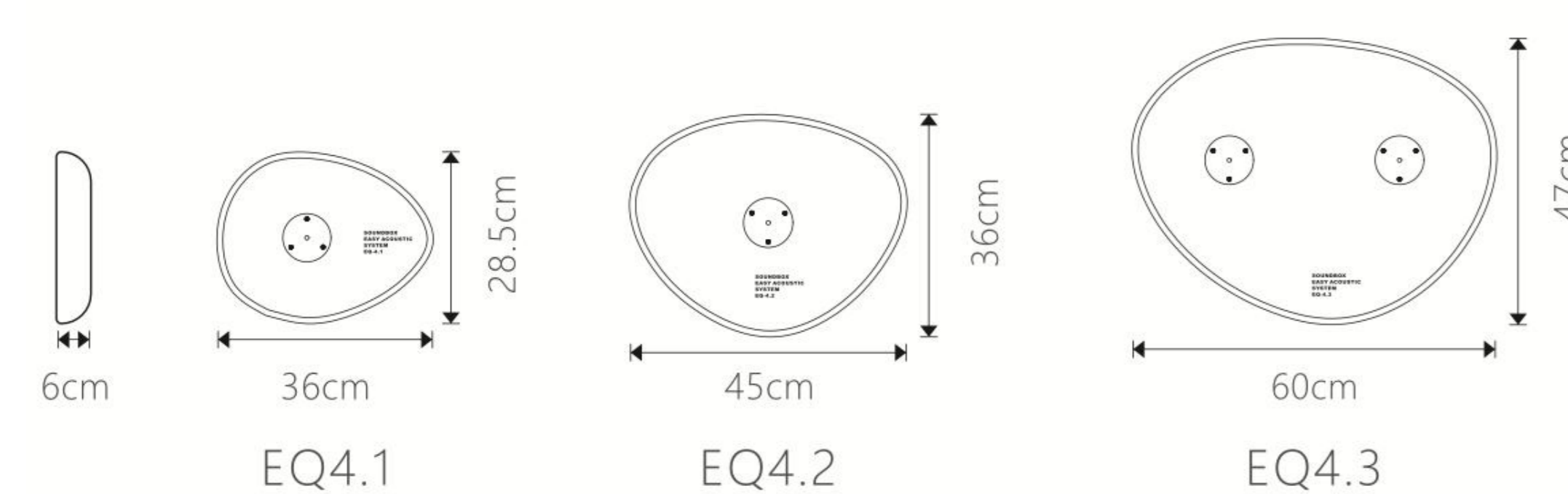

Name: Cobble

Models: EQ4.1 / EQ4.2 / EQ4.3 / EQ4.4

Base Material: Purely natural green fiber acoustic wool

Finish: SF series, fabric acoustic cloth surface finishing

Eco-Friendly: Zero Formaldehyde emission, Enf standard

Weight: EQ4.1~0.43Kg, EQ4.2~0.65Kg, EQ4.3~1.09Kg, EQ4.4~3.57Kg

The "Cobble" offers well preformed acoustical function, delivers a perfect combination, artistic approach and aesthetics.

It can cover the main reflection surface and reduce the spatial reverberation phenomenon.

Its standard anti-oxidization and anti-resonance treated aluminum fixing system makes its installation very easy.

Application: Office, Conference room, reception space, leisure room, home cinema, studio etc.

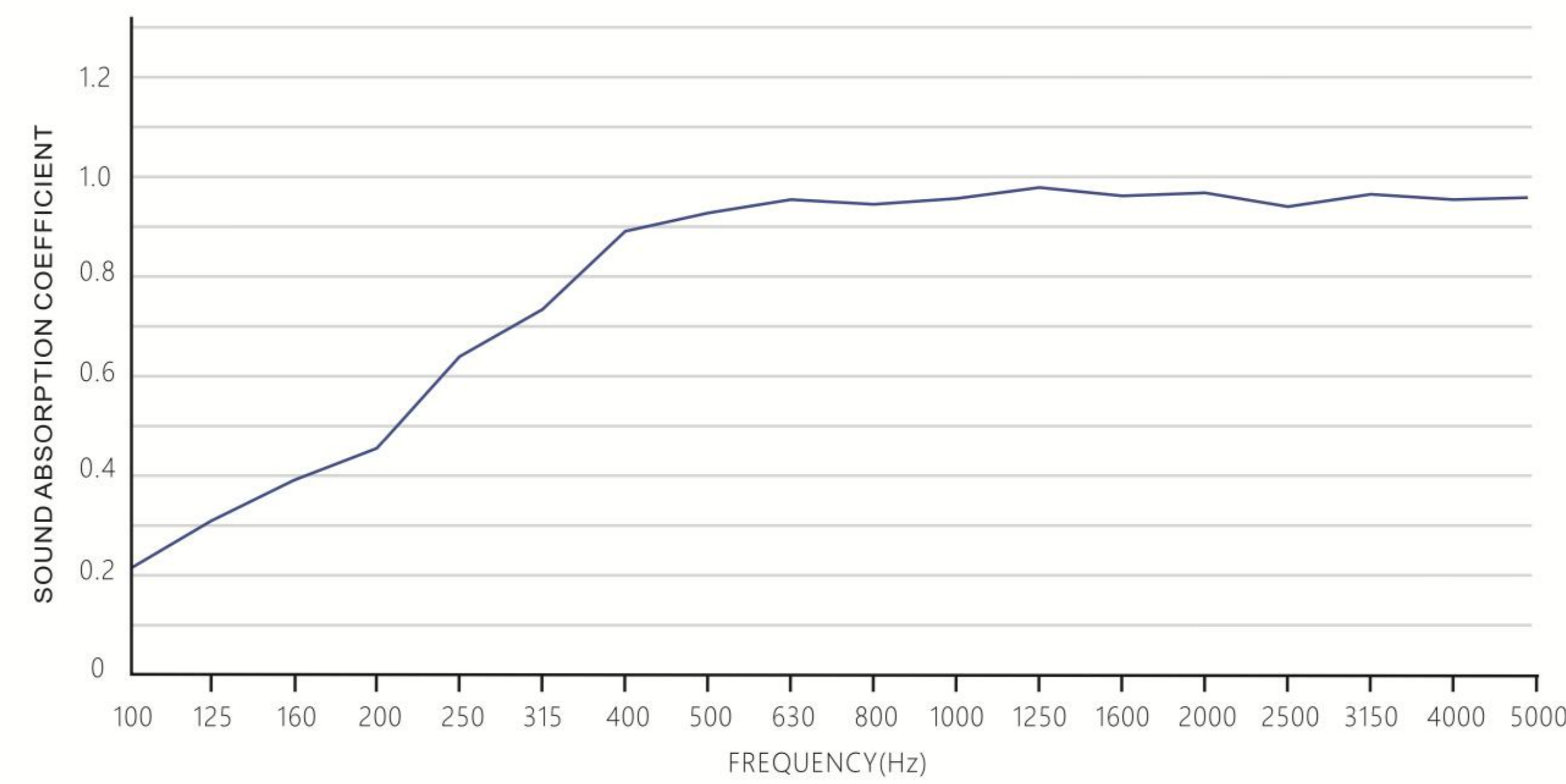

Package

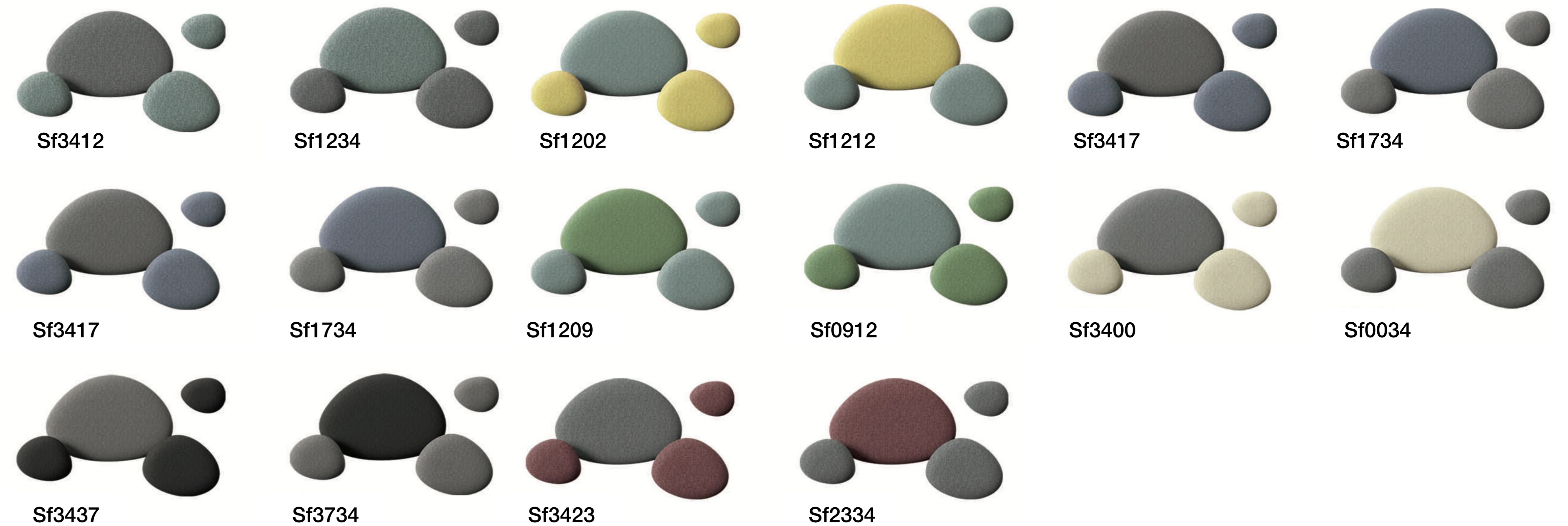
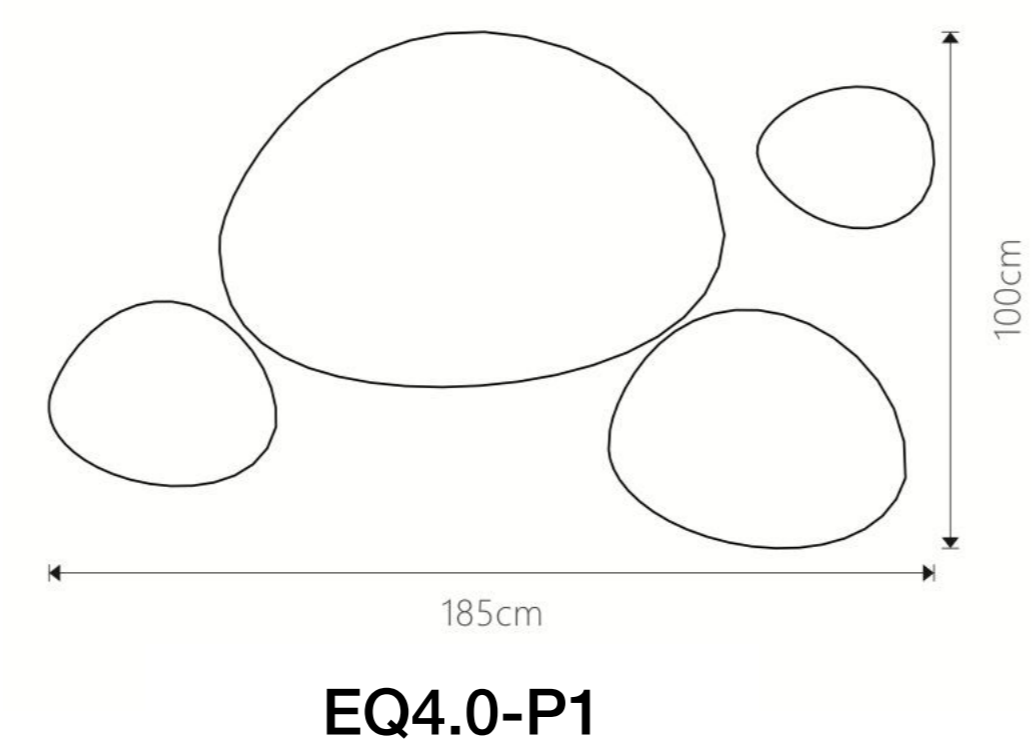



SF-1200 SF-1202 SF-1209 SF-1212 SF-1217



SF-1233 SF-1234 SF-1237 SF-1223

Package

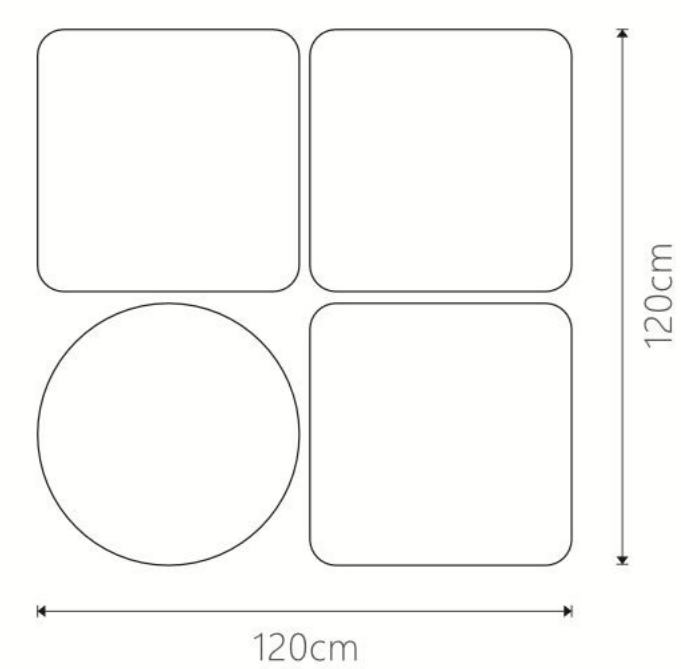

EQ5.0-P1

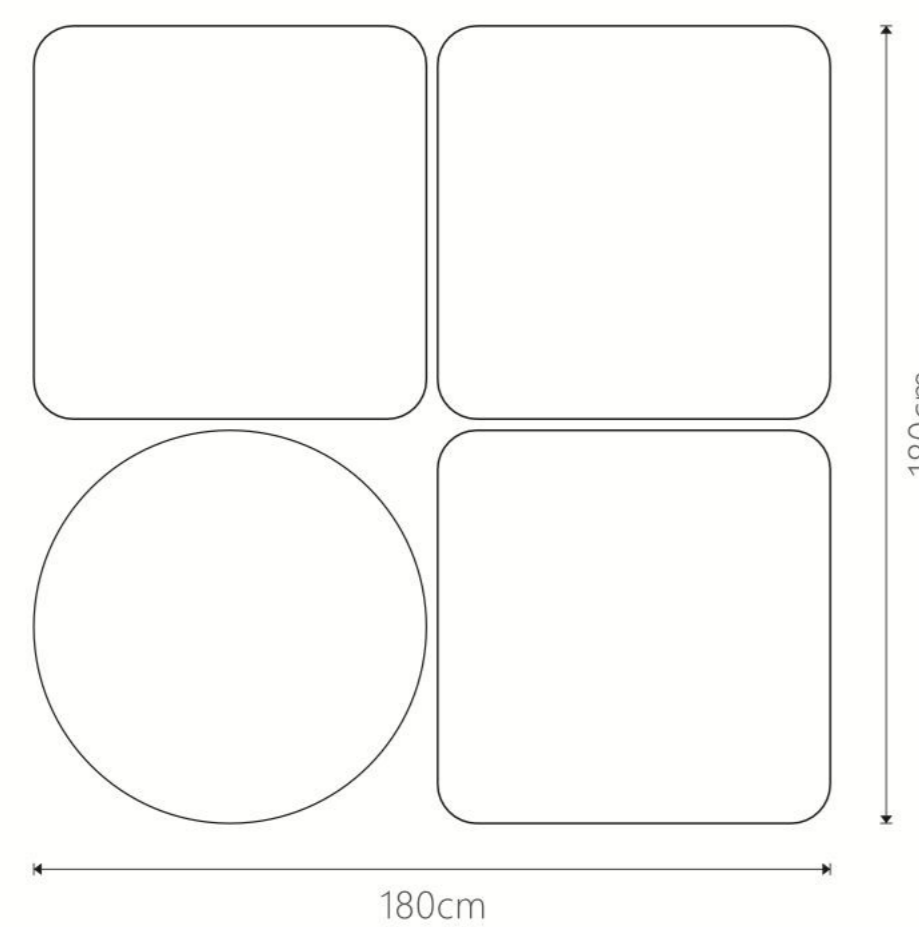

EQ5.0-P2

Name: Geometric

Models: EQ5.1Q / EQ5.2Q / EQ5.1R / EQ5.2R

Base Material: Purely natural green fiber acoustic wool

Finish: SF series, fabric acoustic cloth surface finishing

Eco-Friendly: Zero Formaldehyde emission, Enf standard

Weight: H600~1.96Kg, H900~3.64Kg, R600~1.52Kg, R900~2.92Kg

with the "Geometric" it is easy to meet space acoustic standards. It was developed and evolved using rigorous functional data and combined materials so it will absorb the broadband frequency perfectly.

Its standard anti-oxidization and anti-resonance treated aluminum fixing system makes its installation very easy. And so creating an acoustic environment could not be easier.

Application: Office, Conference room, reception space, leisure room, home cinema, studio etc.

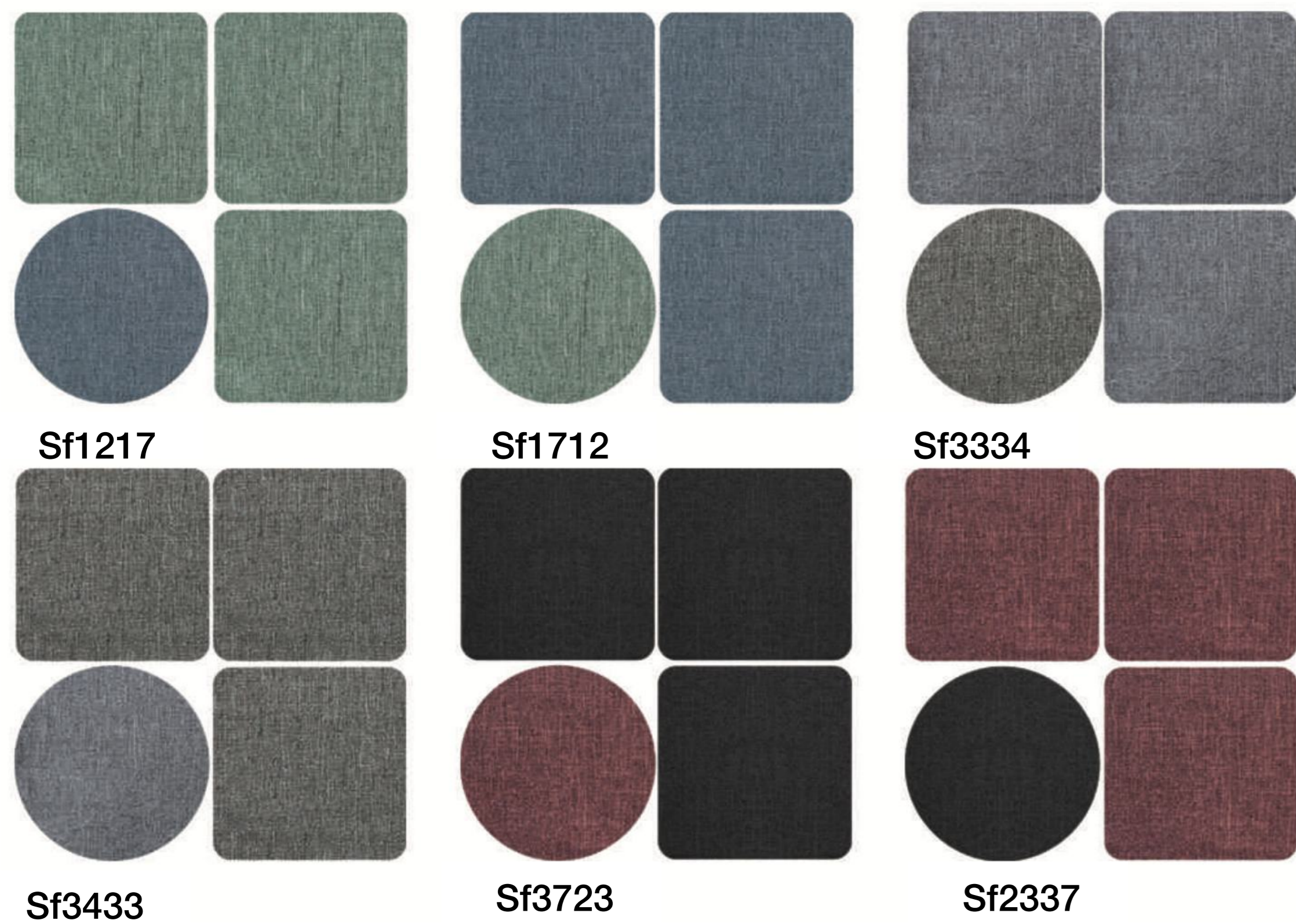
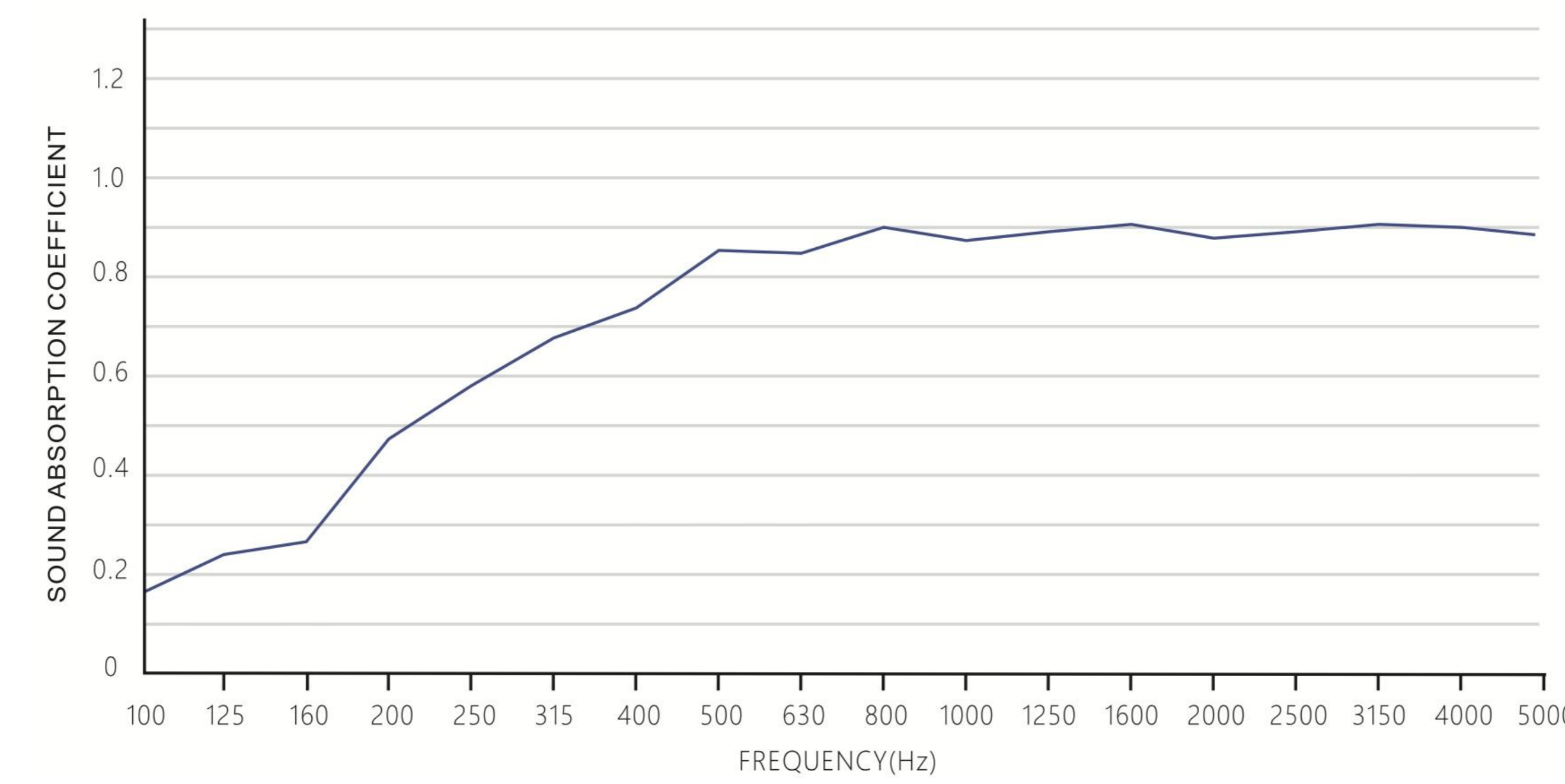

Installation diagram

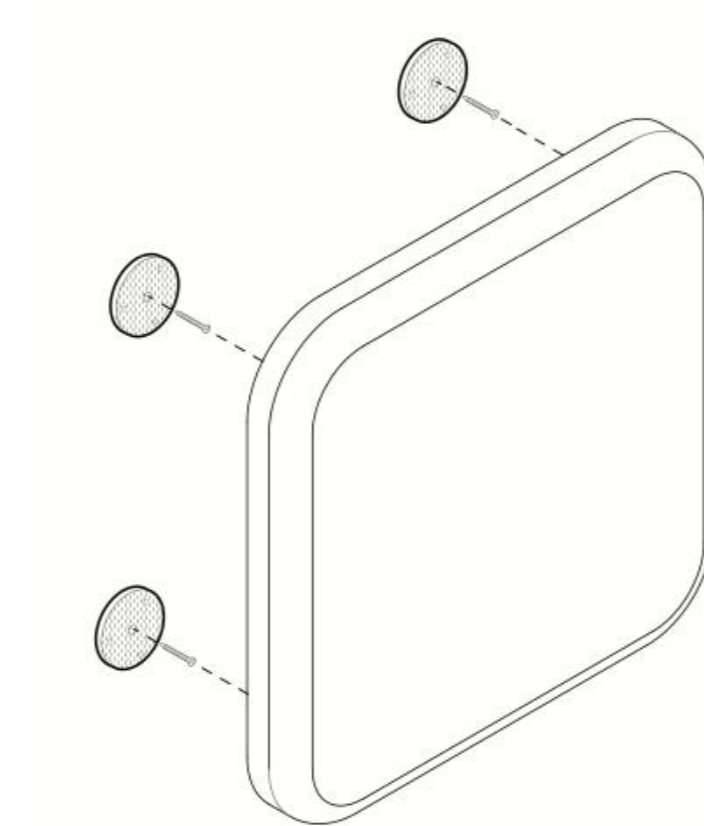

Wall mounting installation diagram

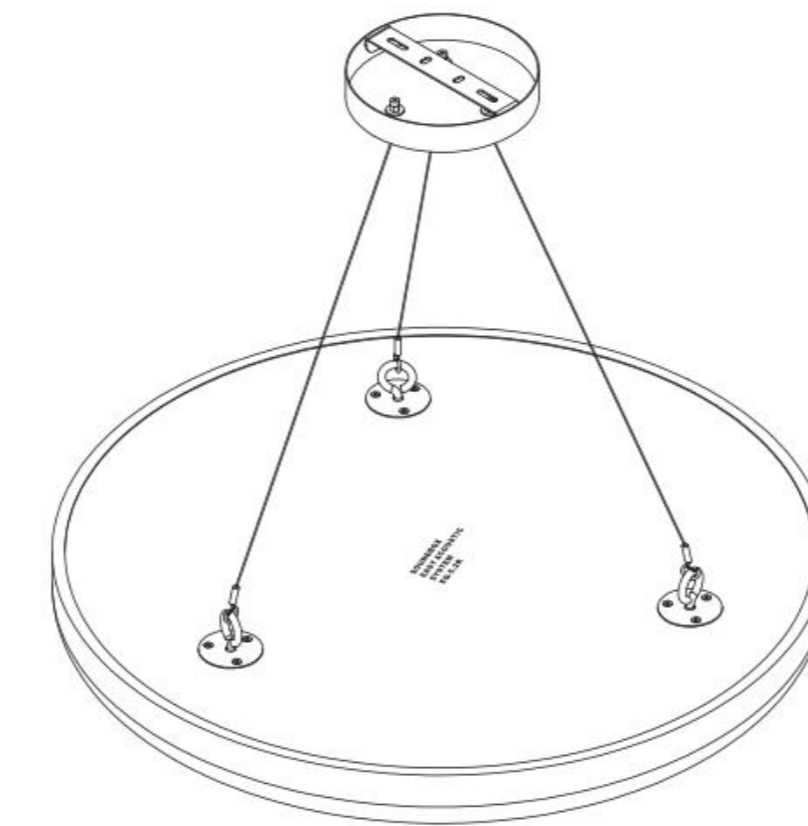

Hanging installation diagram

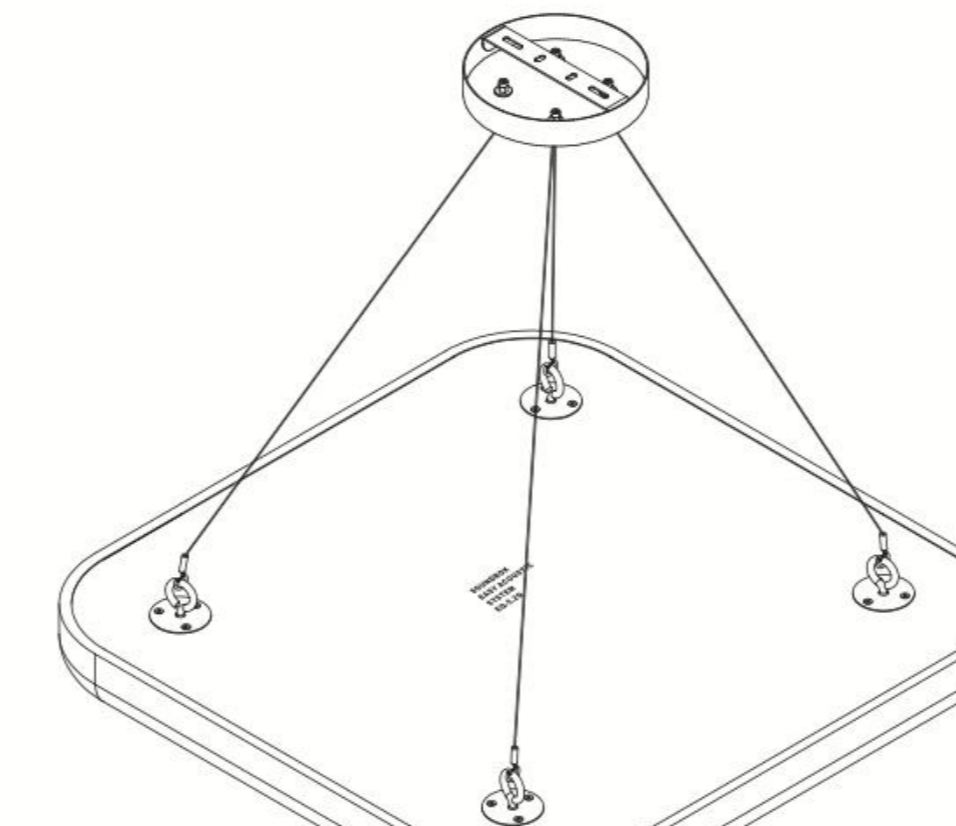

Hanging installation diagram

Size

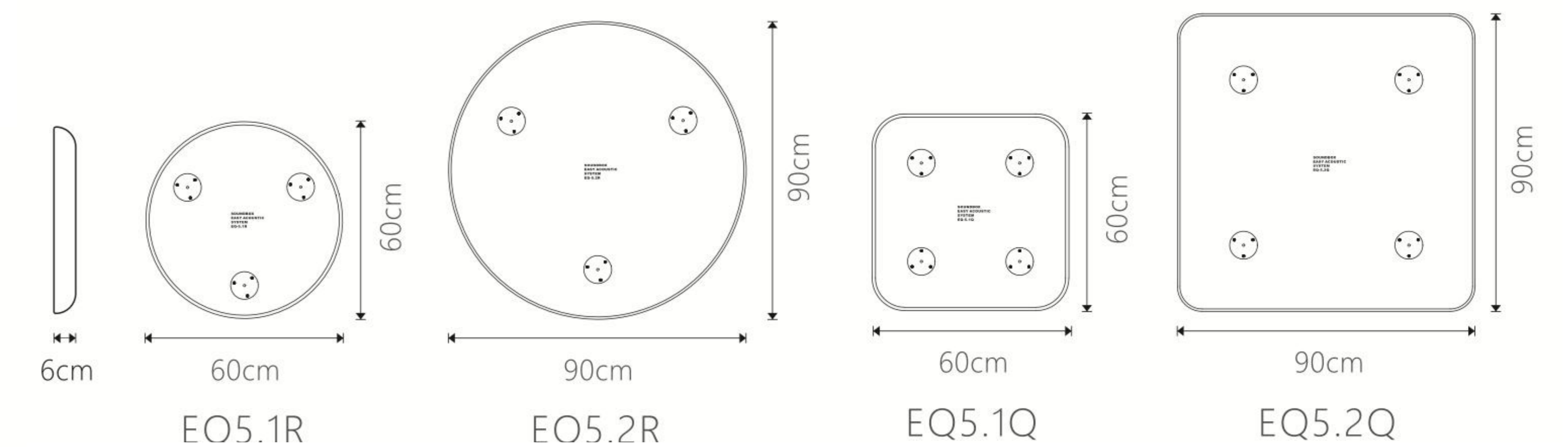

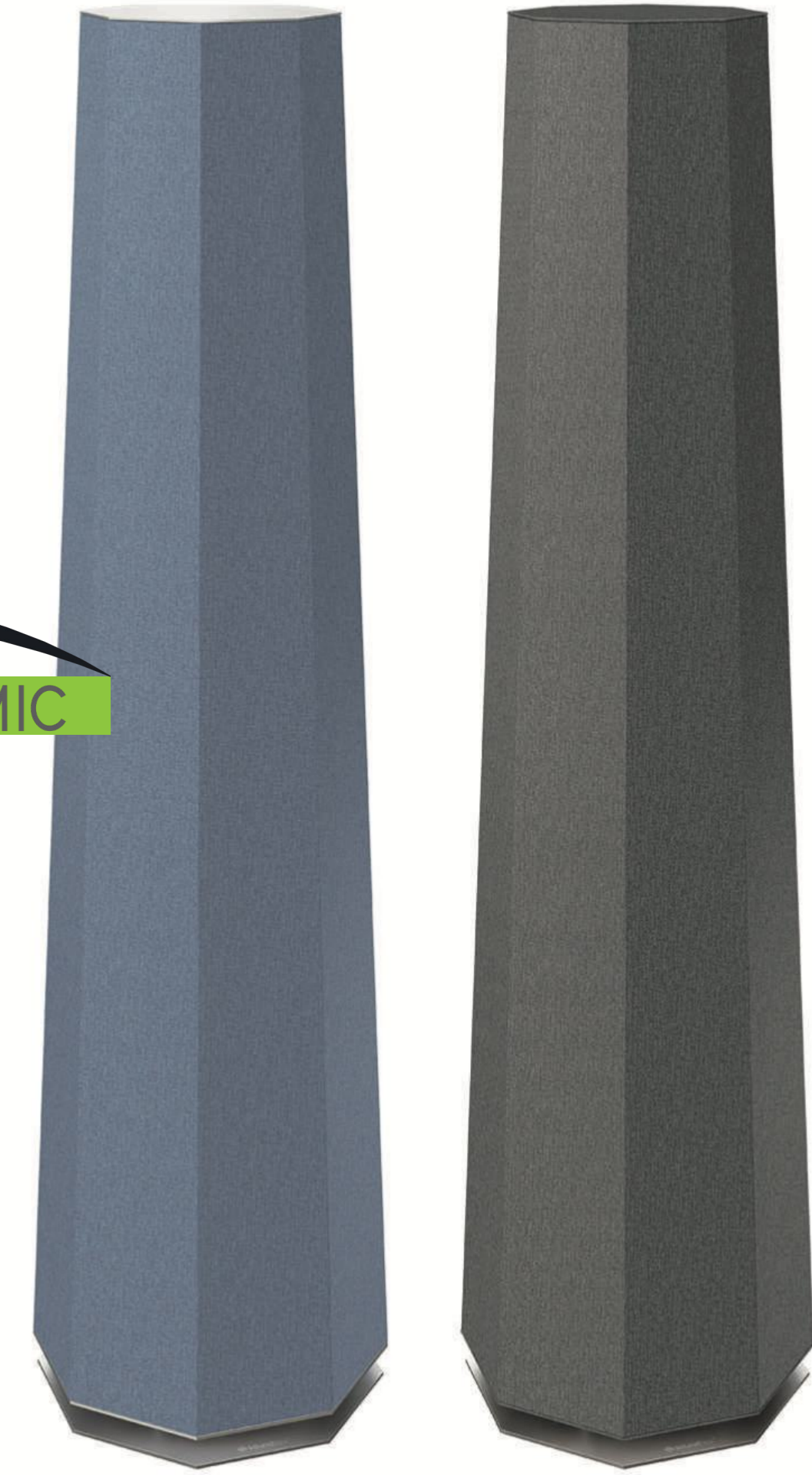

Name: Cylinder Basstrap

Models: EQ101A(Built-in Helmholtz resonator) / EQ101B

Base Material: Eco-friendly composite acoustic wool of different density

Finish: SF, 14 series, fabric acoustic cloth surface finishing

Eco-Friendly: Zero Formaldehyde emission, E0 standard

Weight: EQ101A~12.6Kg, EQ101B~12.7Kg

Size: H1500*W400*D250mm



Acoustic structure:

The eight-sided cone absorbing device and asymmetric volumetric, can create a more advantageous broadband absorption cavity. The cylindrical 360-degree sound - absorbing surface, absorbs the margin low-frequency waves gathered at the corners.

The A model is specially engineered for higher spatial sound indicators which better absorbs the 63Hz .

The Cylinder Basstrap acts on the absorption of low frequencies and matches the EQ50R and other sound absorbing panels perfectly to create a high-quality sound environment in a small space.

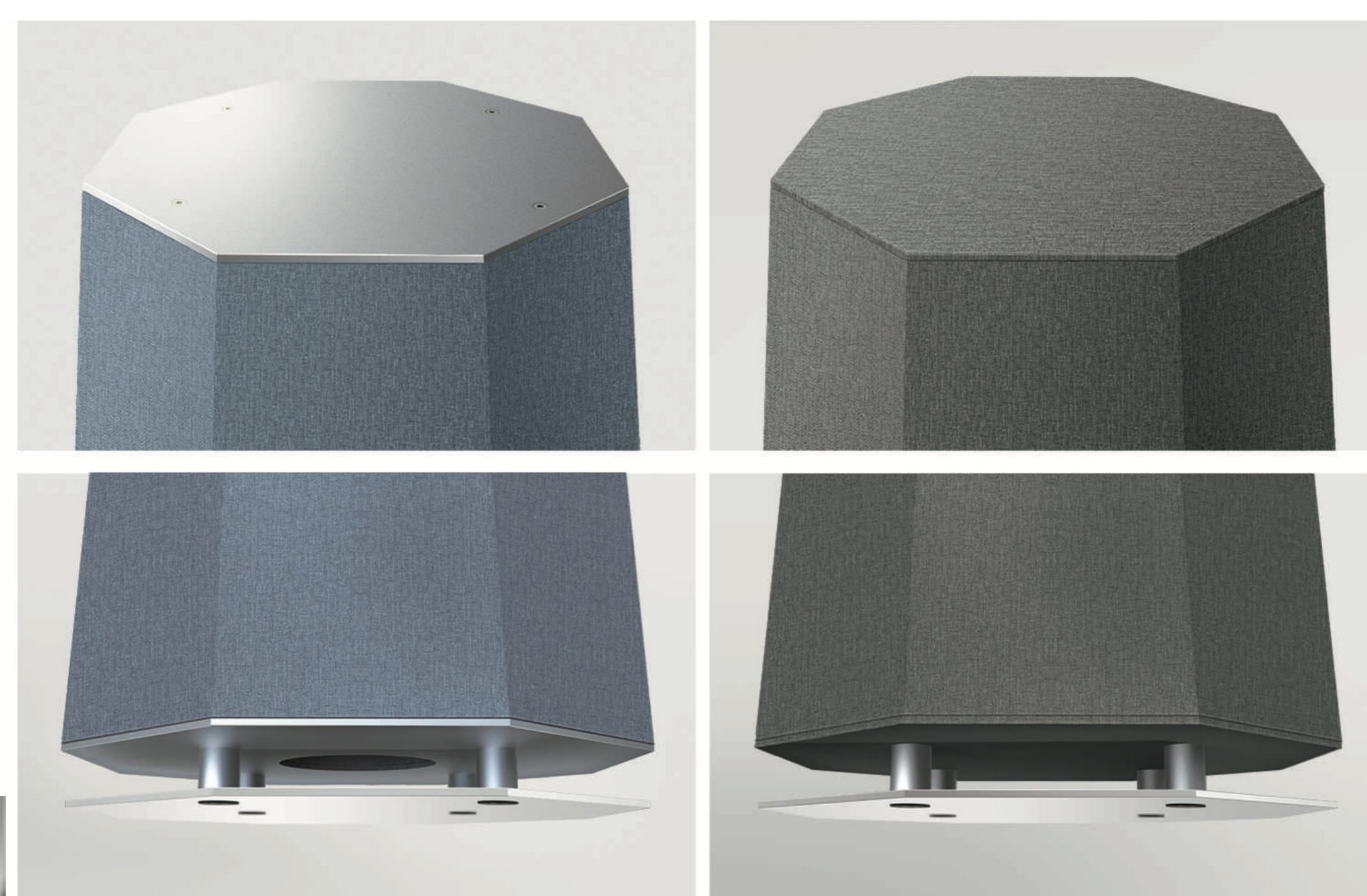

Name: Corner Basstrap

Models: EQ102A(Built-in Helmholtz resonator) / EQ102B

Base Material: Eco-friendly composite acoustic wool of different density

Finish: SF, 14 series, fabric acoustic cloth surface finishing

Eco-Friendly: Zero Formaldehyde emission, E0 standard

Weight: EQ101A~15Kg, EQ101B~15.3Kg

Size: H1500*W400*D250mm

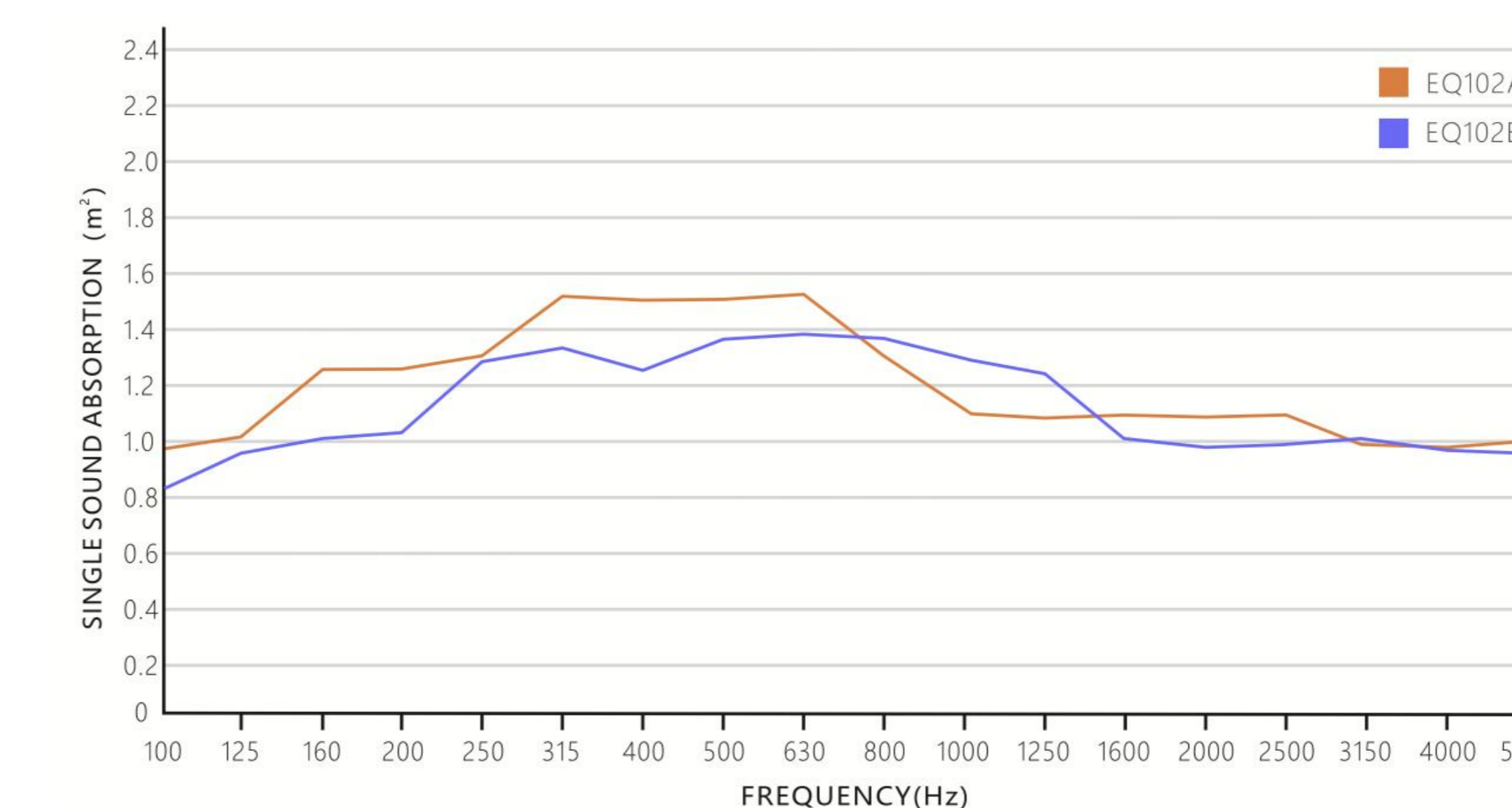
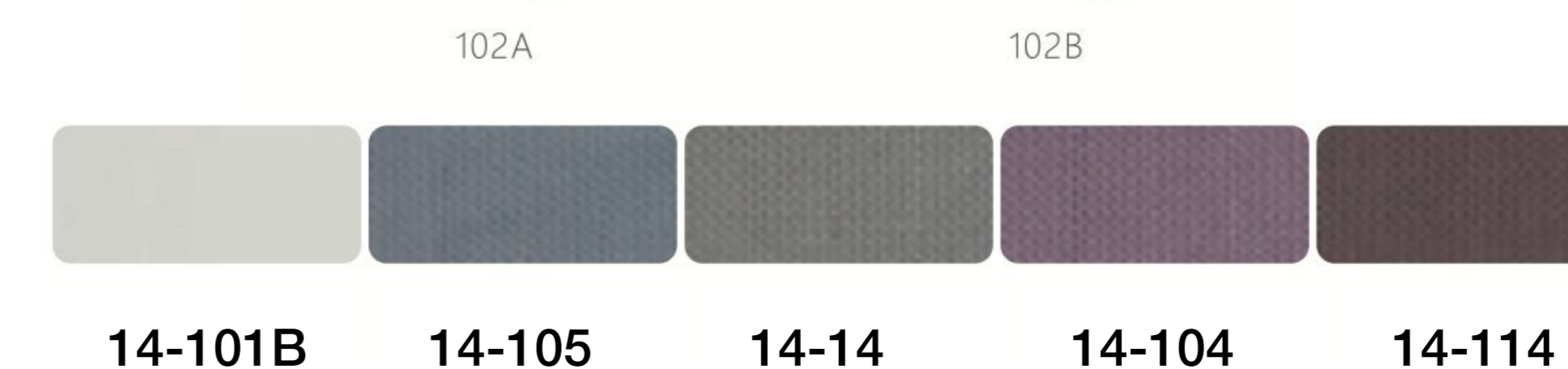

Acoustic structure:

The four-sided trapezoidal strong absorbing device, asymmetric volumetric, can create a more advantageous broadband absorption cavity. The cylindrical 360-degree sound -absorbing surface, absorbs the margin low-frequency waves gathered at the corners.

The A model is specially engineered for higher spatial sound indicators which better absorbs the 63Hz .

The Cylinder Basstrap acts on the absorption of low frequencies and matches the EQ3.0 and other sound absorbing panels perfectly to create a high-quality sound environment in a small space.

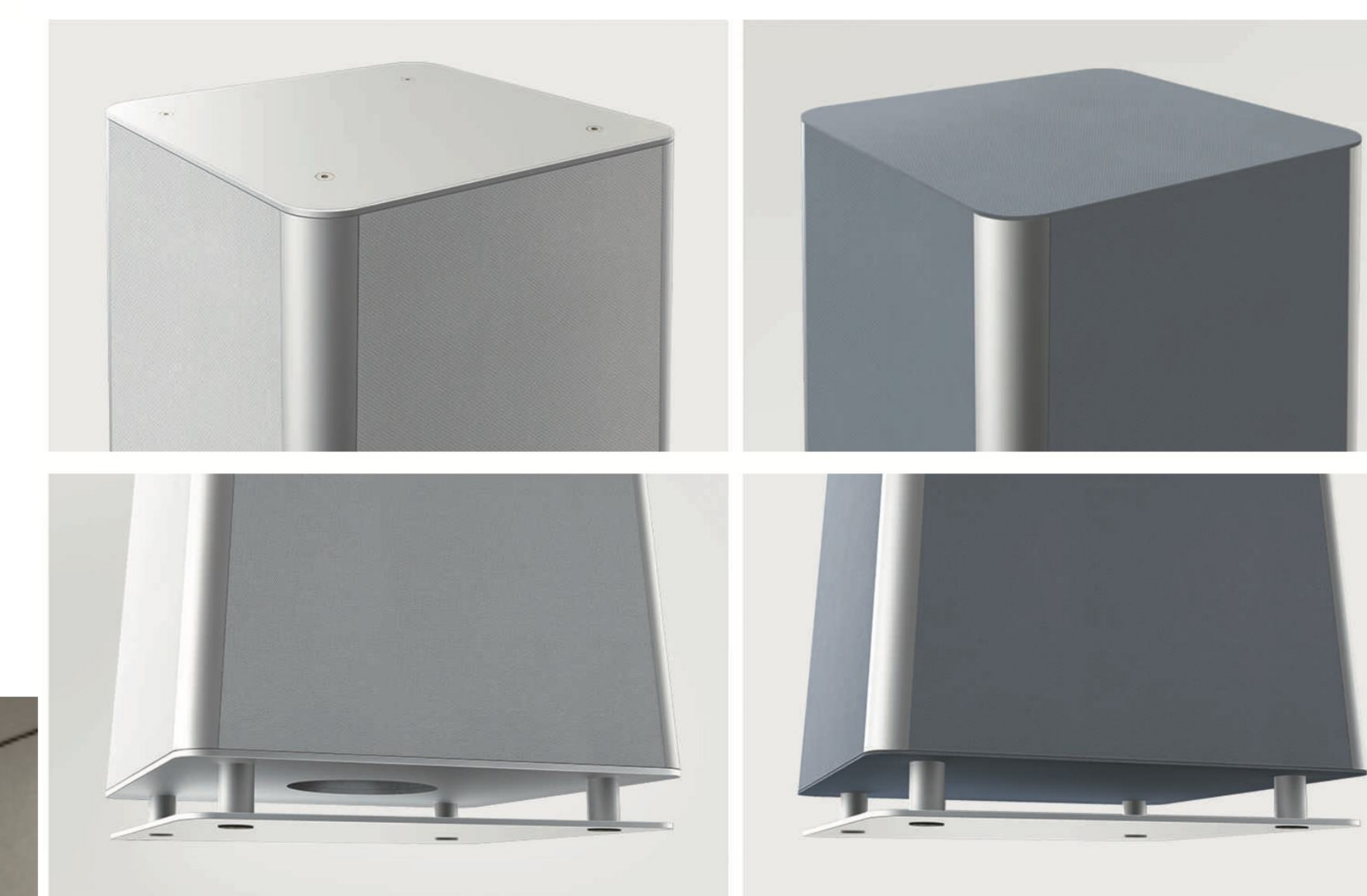



Imagine Acoustic Painting

Natural acoustic cotton substrate made of natural plant ultra-fine fiber as raw material, mixed with 3% PET polyester fiber, and made of 280 degree high temperature and without glue heat compound. The substrate is double-sided with a 100% PET ultra porous acoustic trunk with a large number of unequal radius pores connected to each other, the pores are deep inside the structure, and the internal and external unequal orders of air layer constitute a wide frequency absorber.

The layer of the substrate is also a good acoustic energy sealing structure, and the sound wave penetrates the surface layer to the ultra-micro-long radial pore, and the friction between the substrate material and the material converts the acoustic energy into heat energy, realizing the multi-stage reflection sound and noise that consumes excess space.

- Sound absorbing
- Noise reduction
- Zero emission
- Anti-bacteria

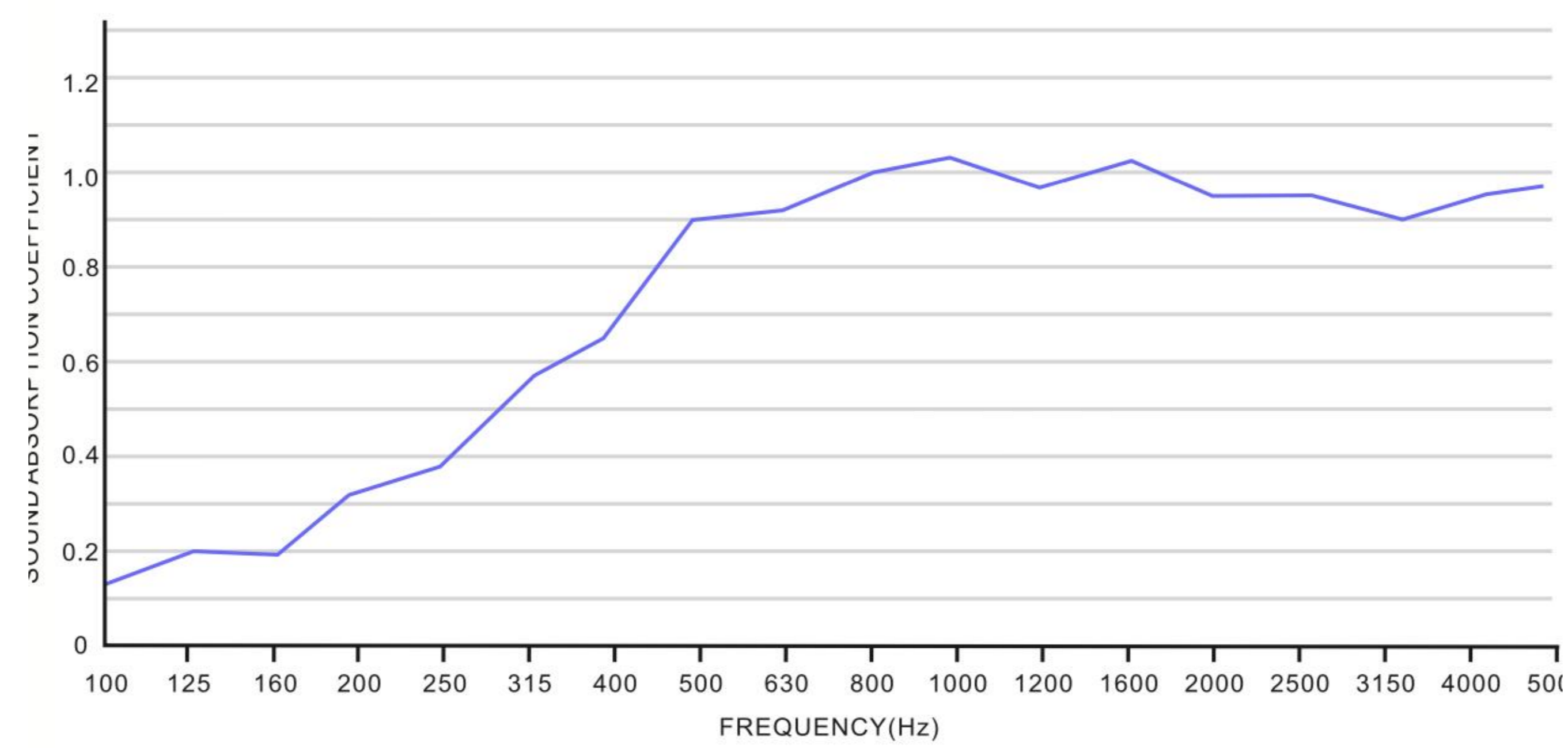

- Home furnishing
- Office
- Commercial
- Hotel
- Education
- Recuperate

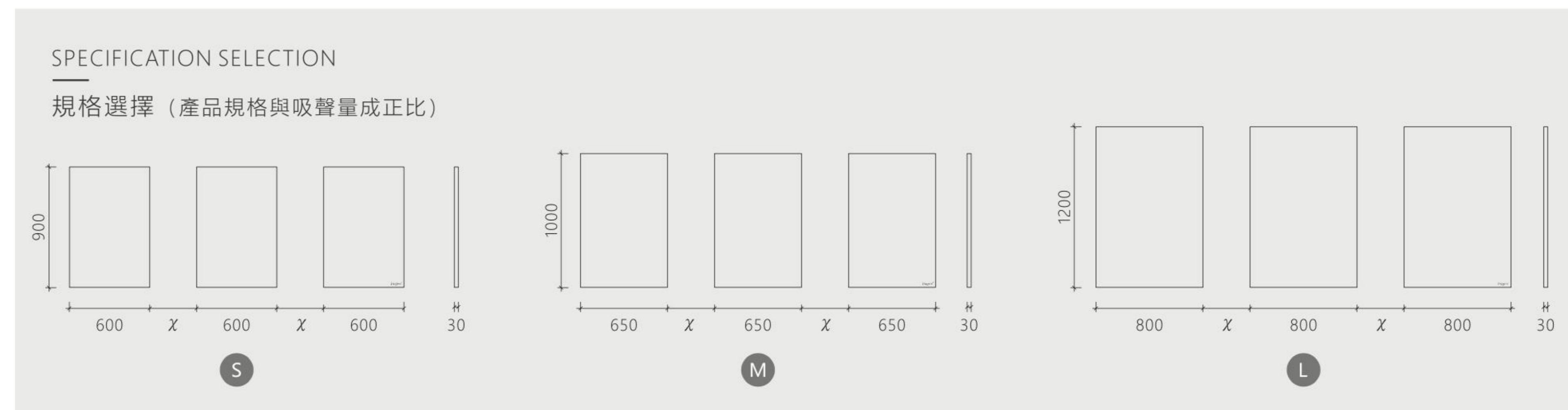

Installation

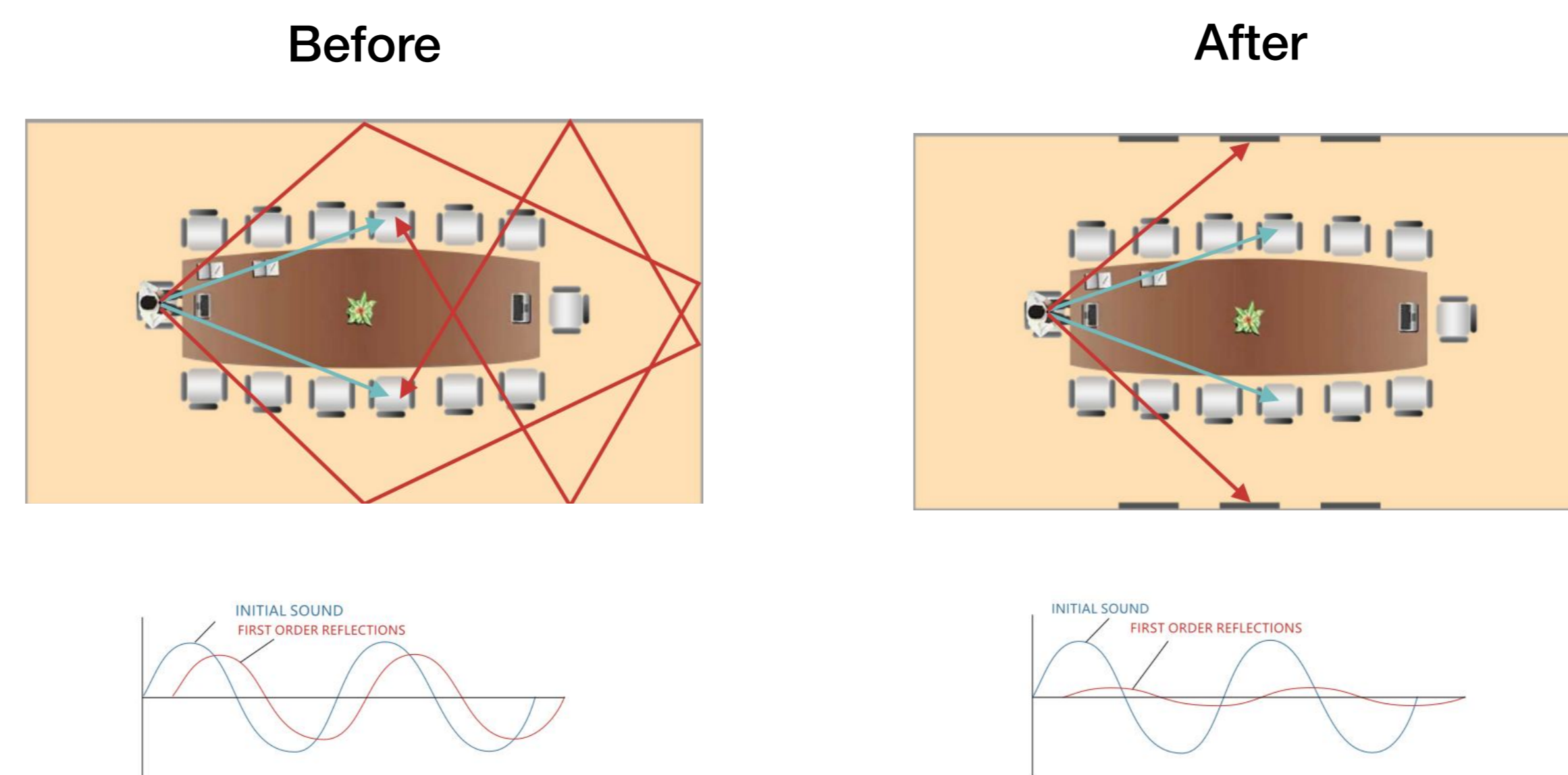
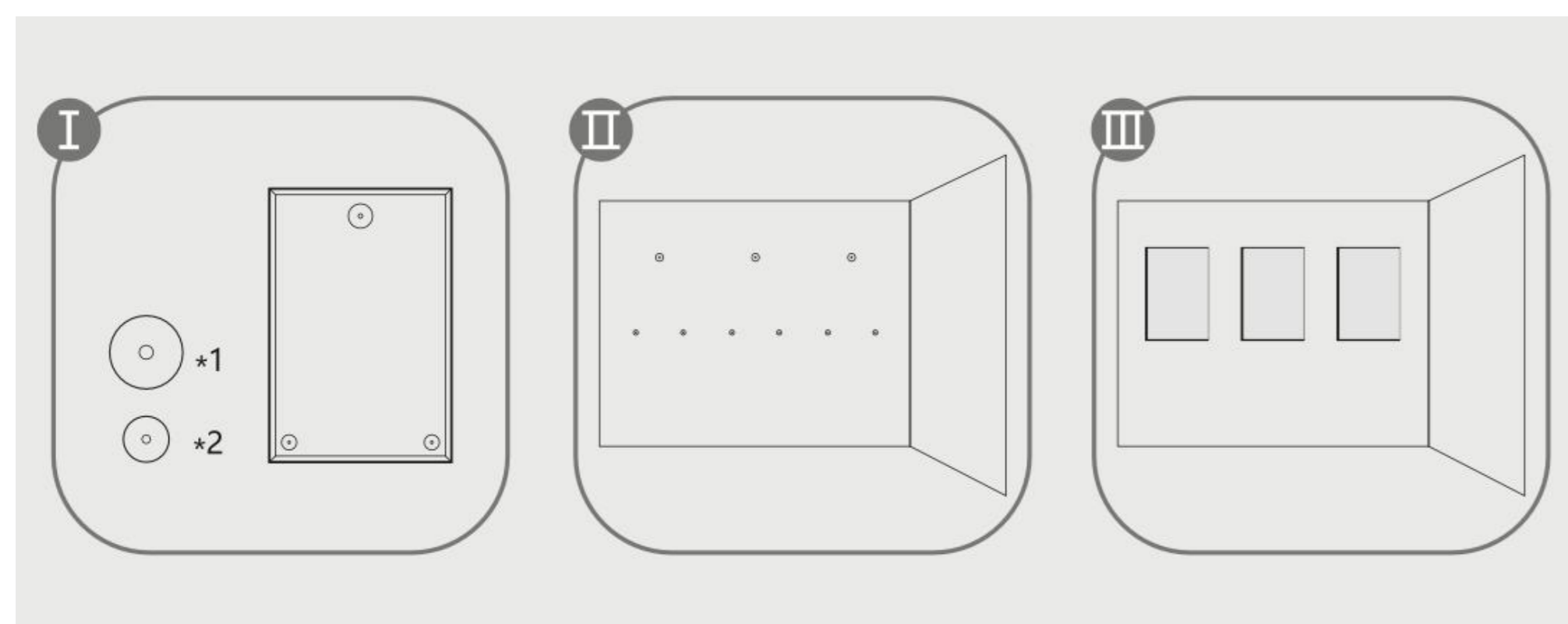

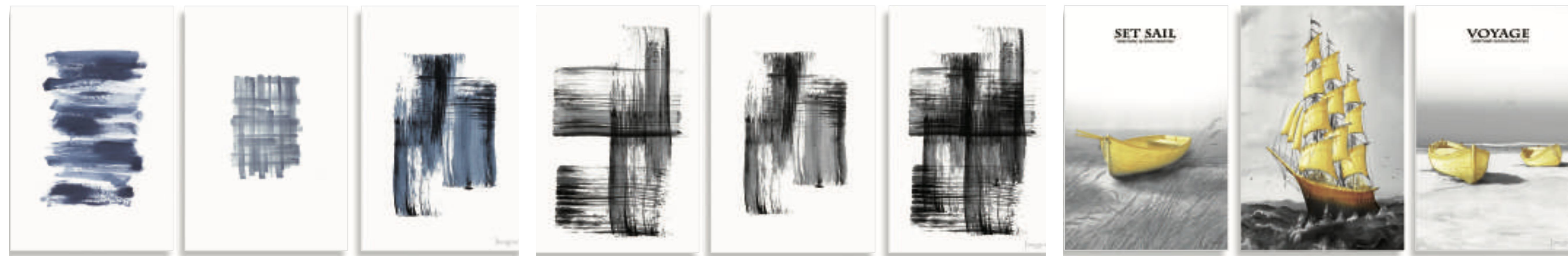
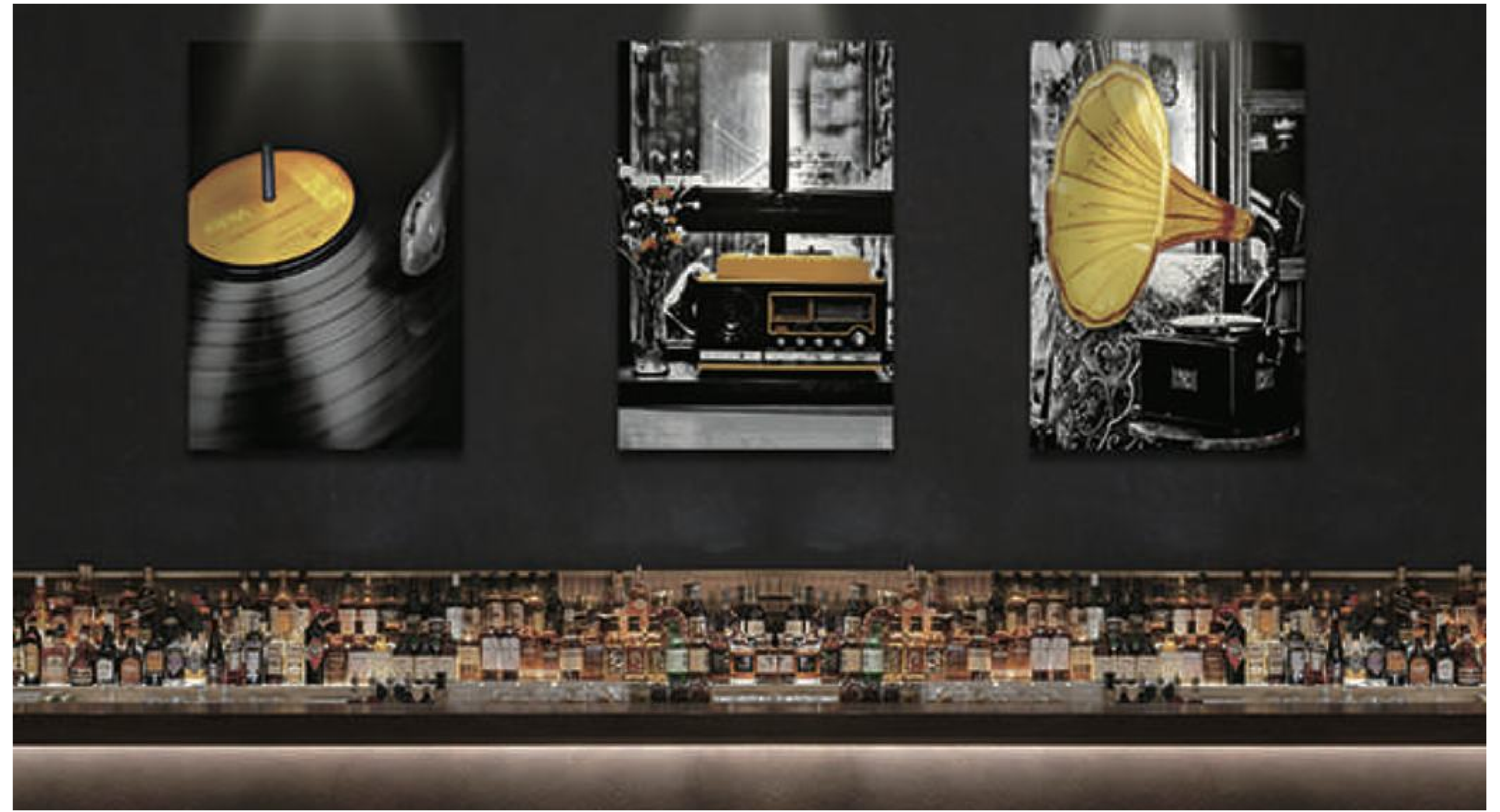

P01 P02 P03



P10 P11 P12



P04 P08 P06



P13 P14 P15



P07 P05 P09

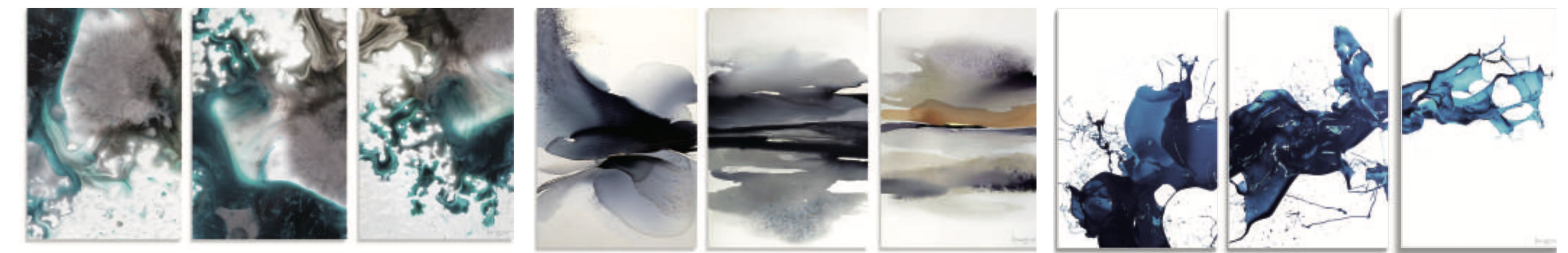

P16 P17 P18

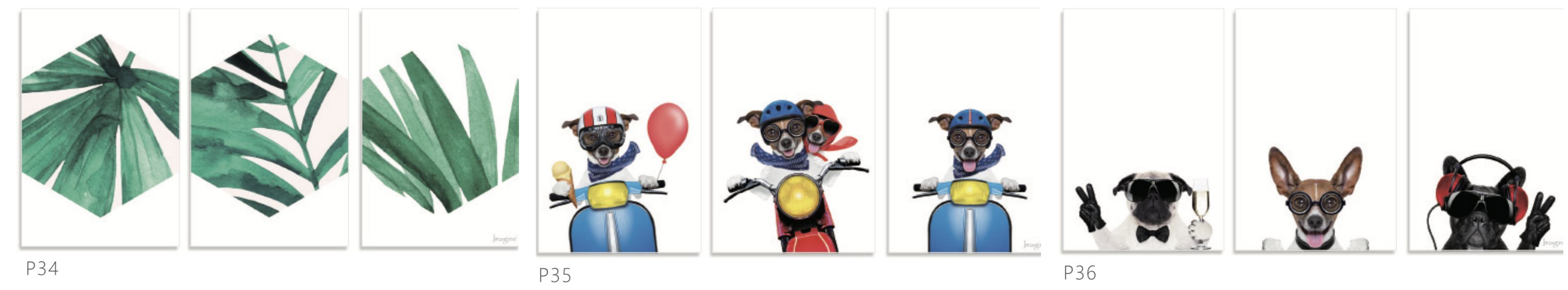
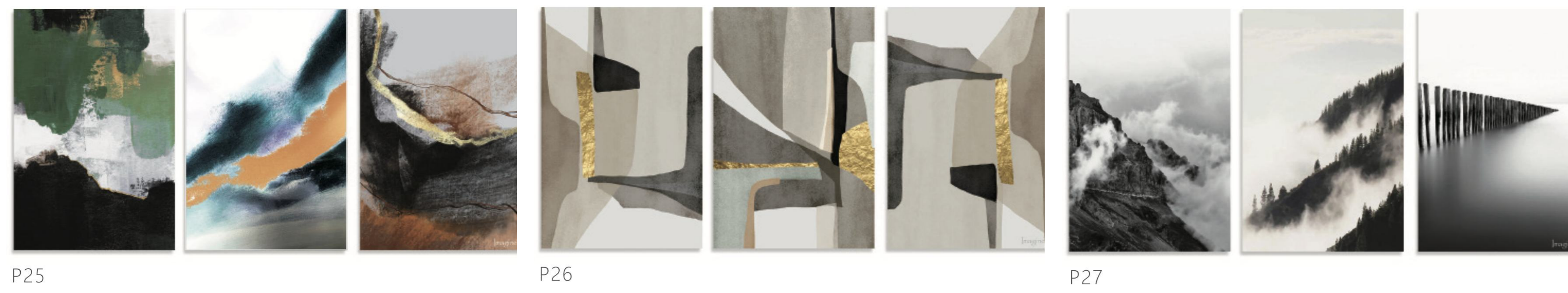
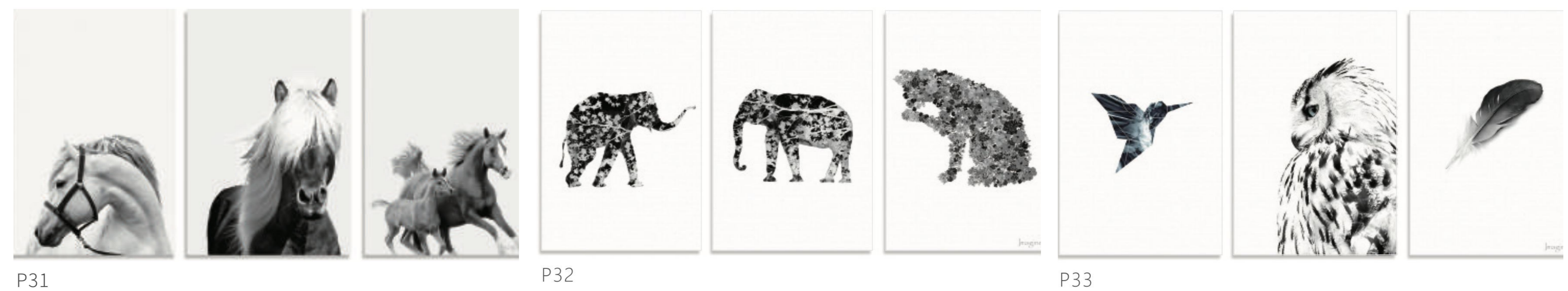
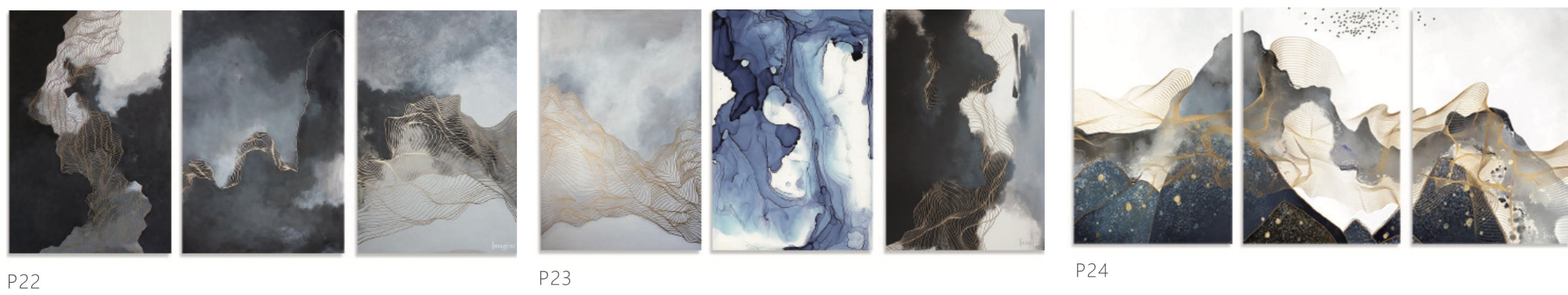

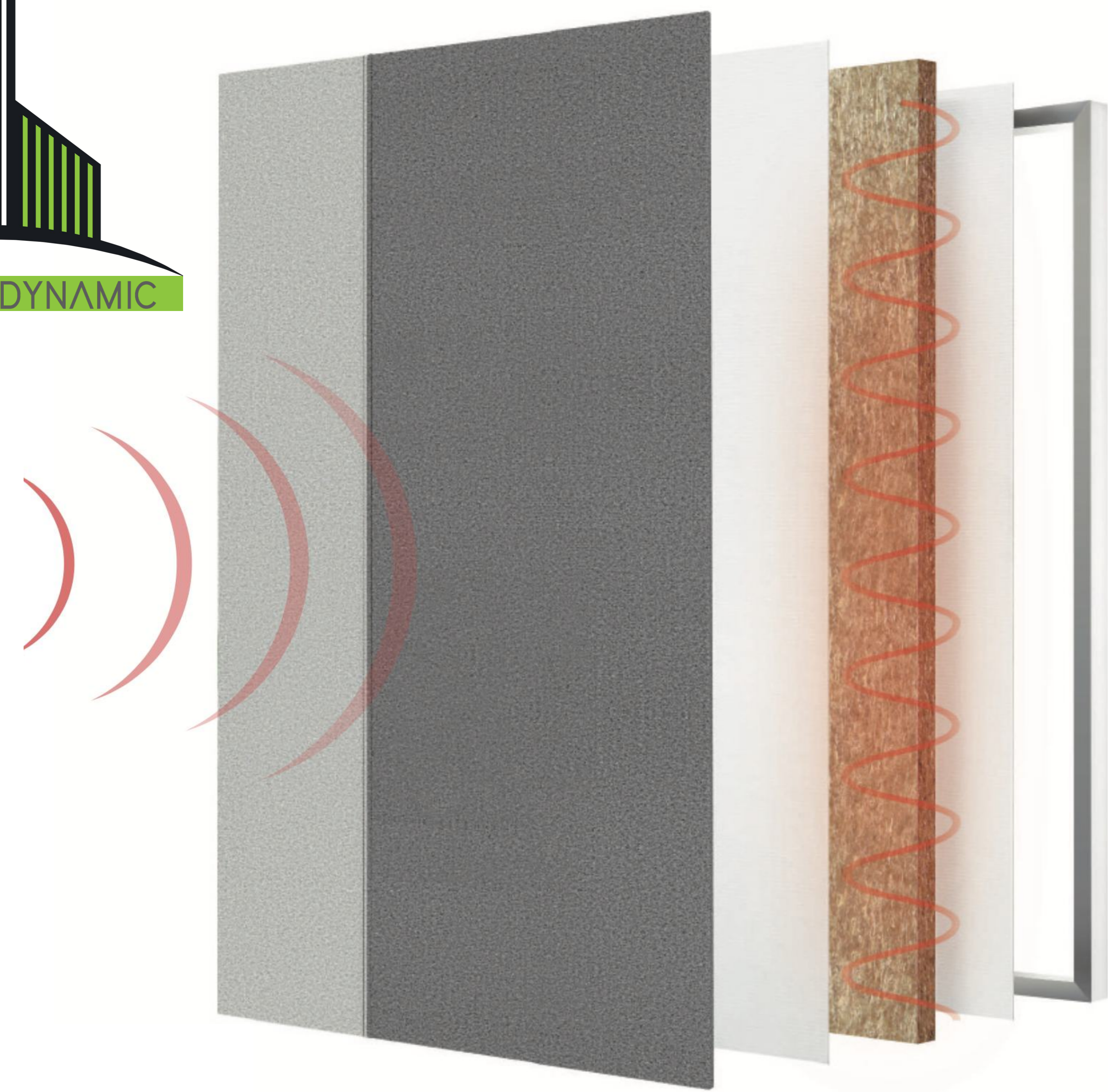

Imagine Acoustic Painting

Natural acoustic cotton substrate made of natural plant ultra-fine fiber as raw material, mixed with 3% PET polyester fiber, and made of 280 degree high temperature and without glue heat compound. The substrate is double-sided with a 100% PET ultra porous acoustic trunk with a large number of unequal radius pores connected to each other, the pores are deep inside the structure, and the internal and external unequal orders of air layer constitute a wide frequency absorber.

The layer of the substrate is also a good acoustic energy sealing structure, and the sound wave penetrates the surface layer to the ultra-micro-long radial pore, and the friction between the substrate material and the material converts the acoustic energy into heat energy, realizing the multi-stage reflection sound and noise that consumes excess space.

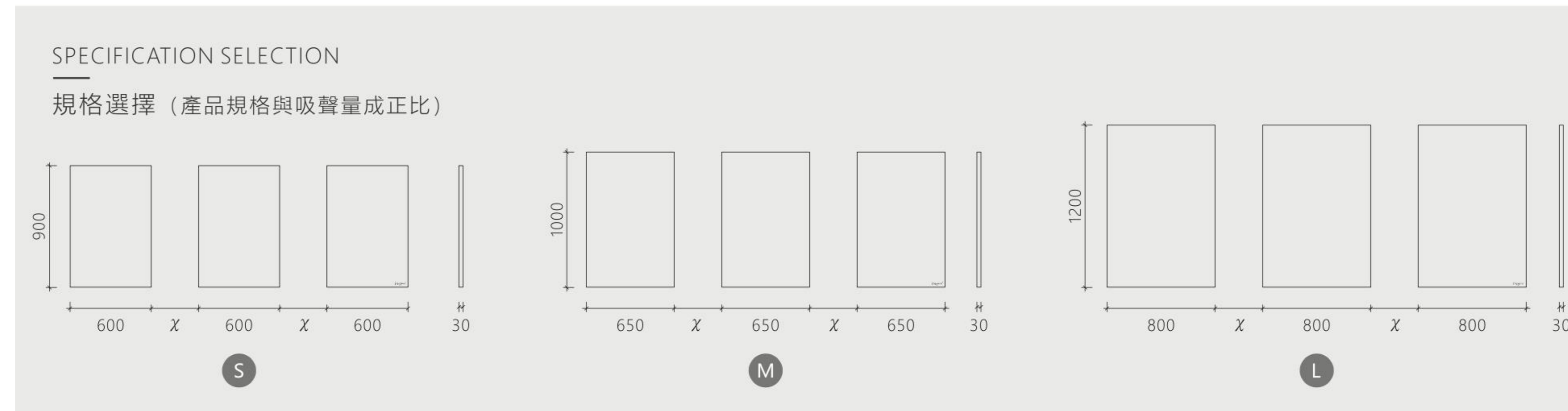
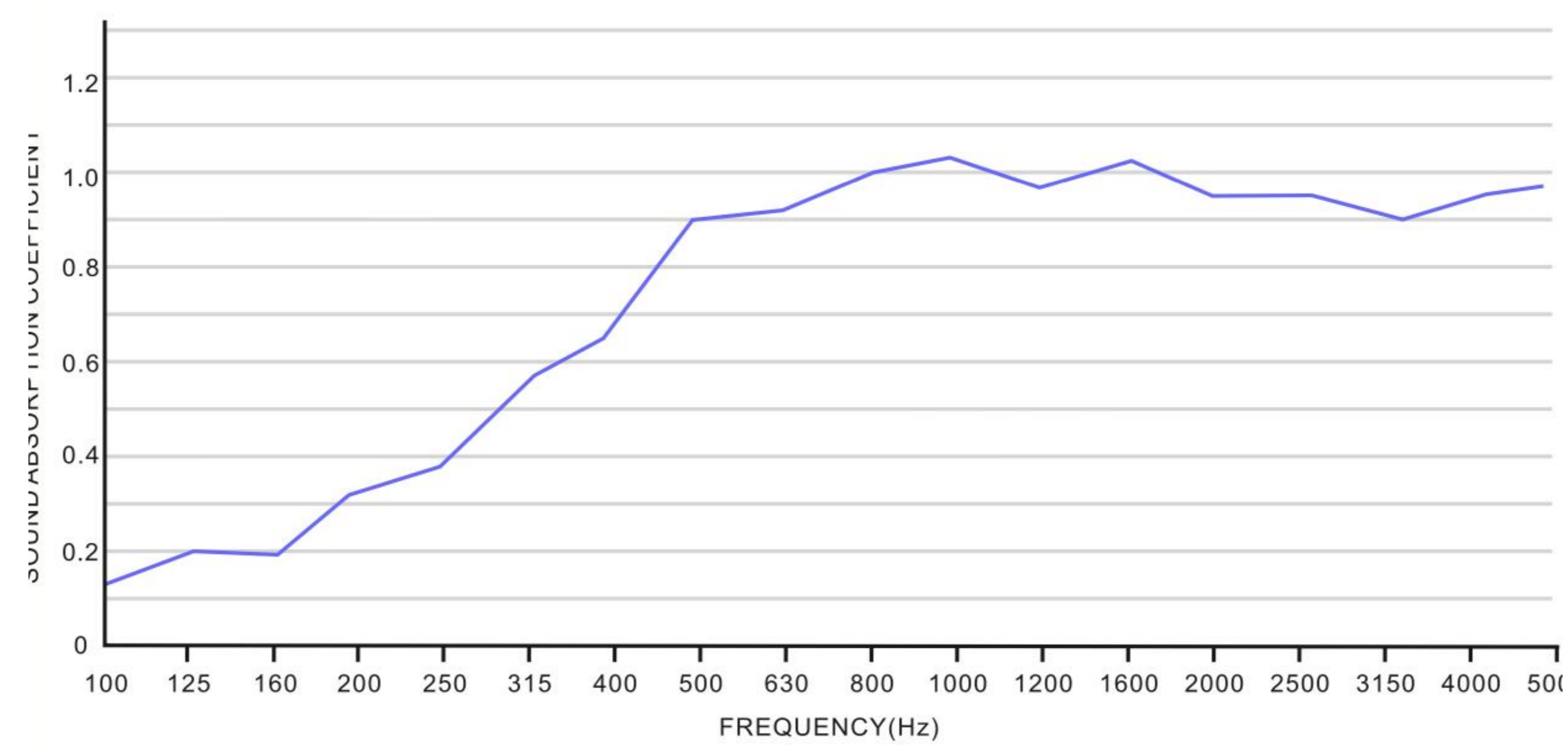
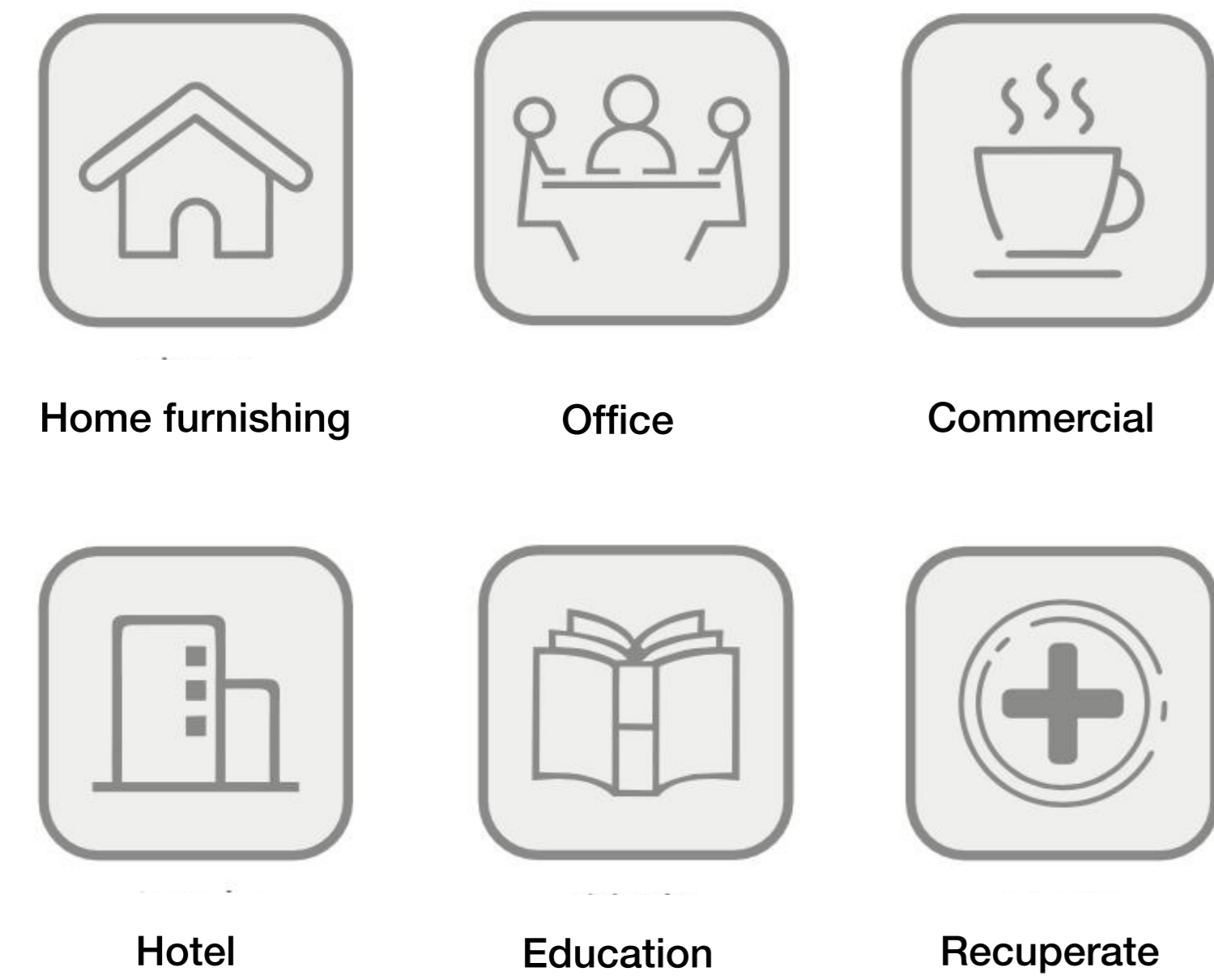
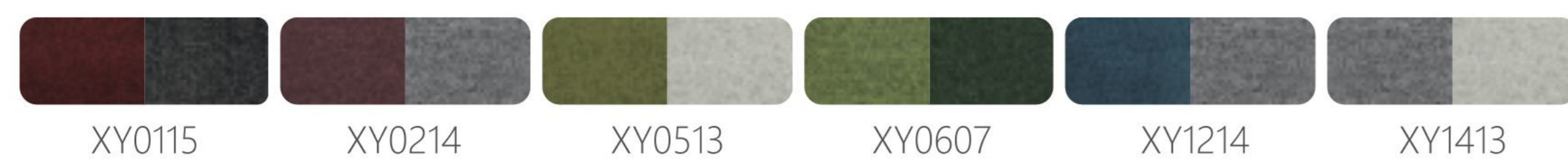

Installation

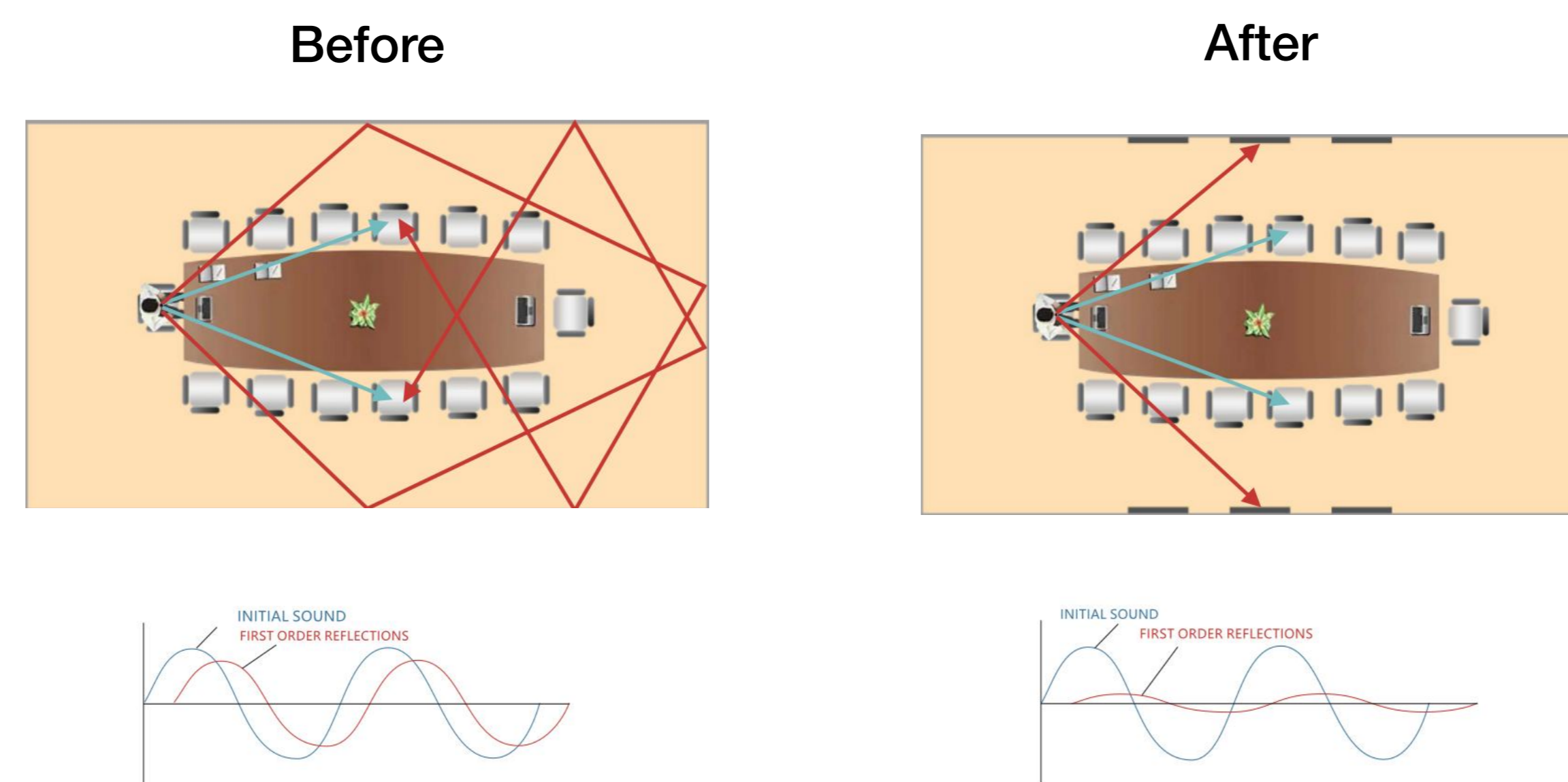
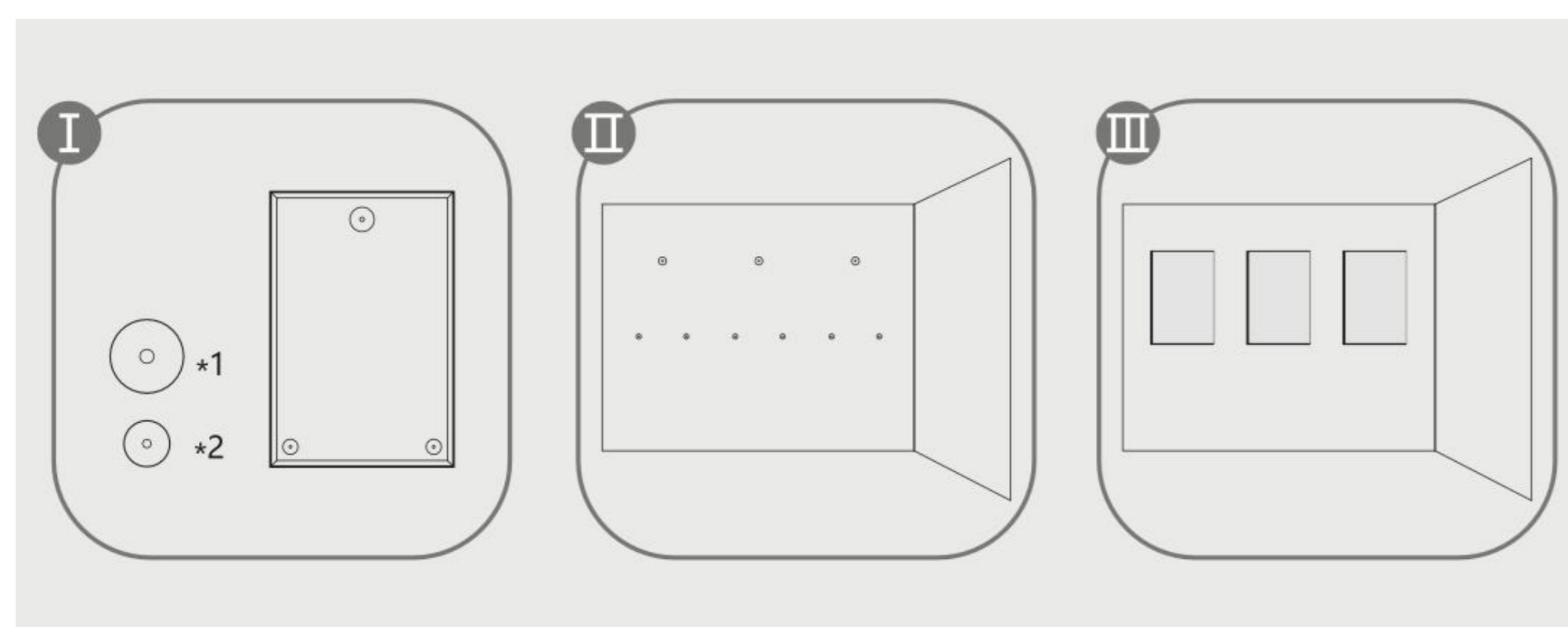

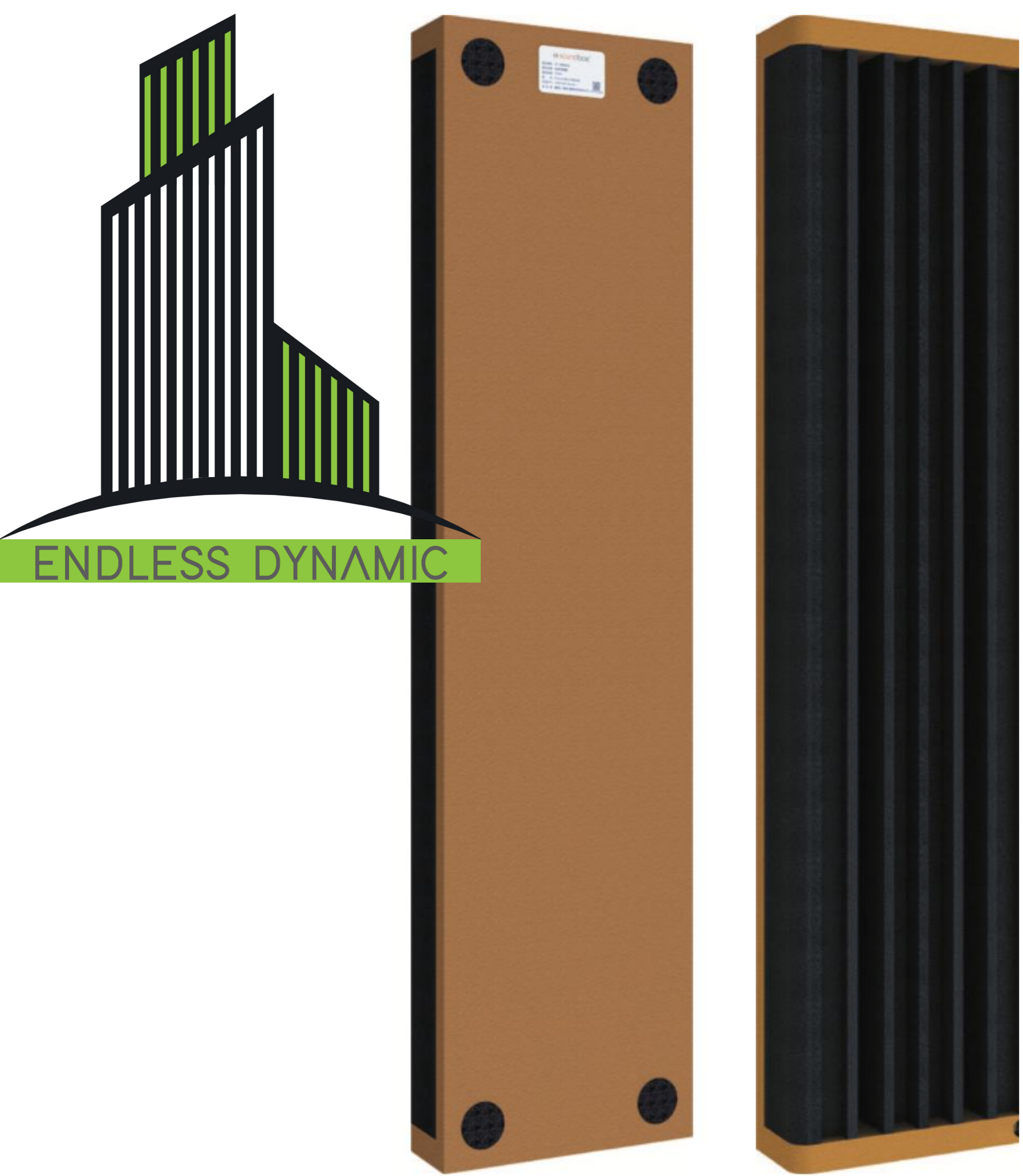

Name: DQ High Frequency Absorber

Models: F300H

Base Material: Polymer / Polyether polyol fire retardant acoustic foam

Finish: E0 Eco-friendly water based paint

Eco-Friendly: Zero Formaldehyde emission, E0 standard

Weight: ~ 1.3 Kg/pcs

Size: H1200*W300*D100mm

Acoustic structure:

High density Polyether polyol acoustic foam improves sound absorption; QRD array achieves broad band frequency absorption, and create balanced reflection (by dealing with the high frequency excess).

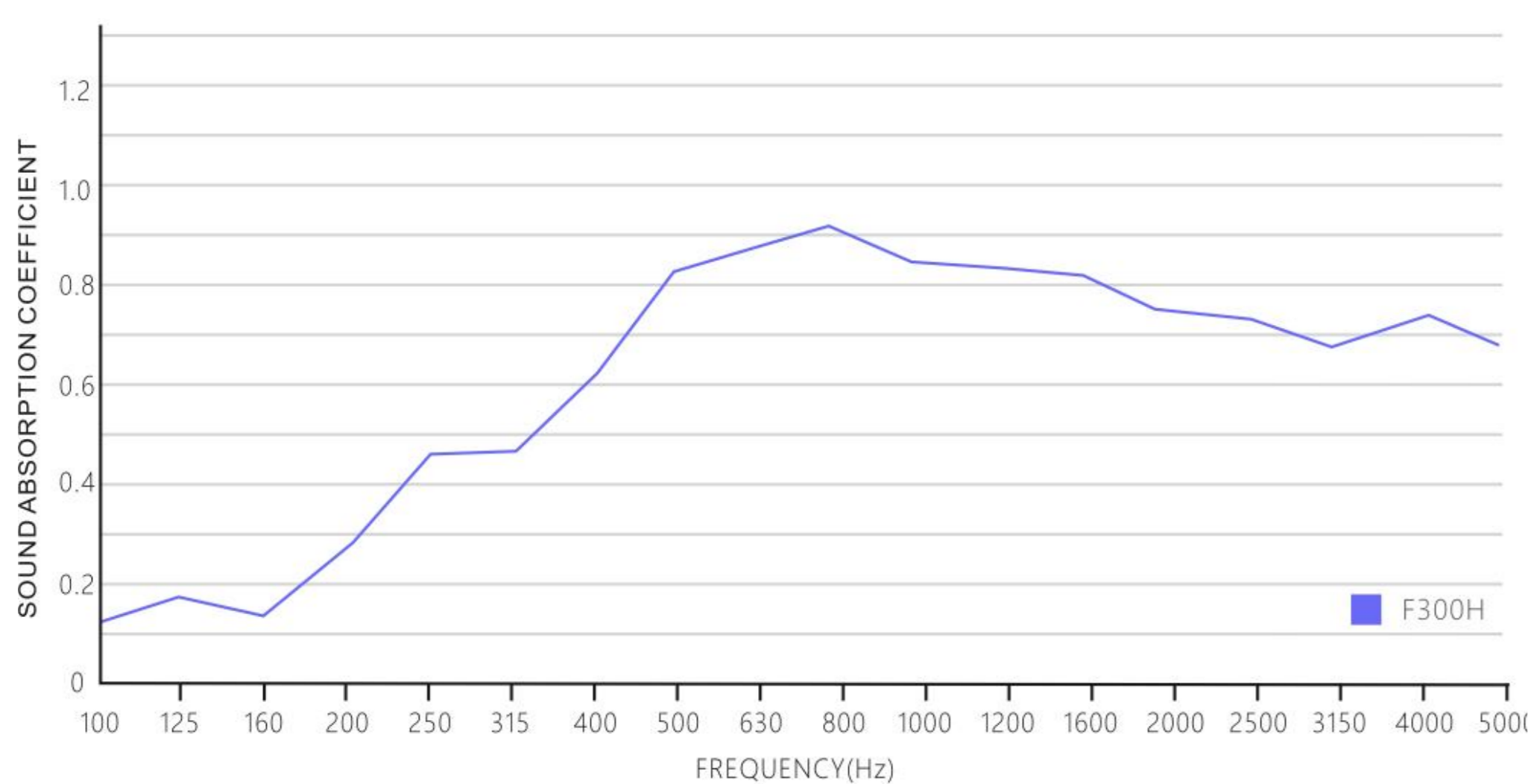
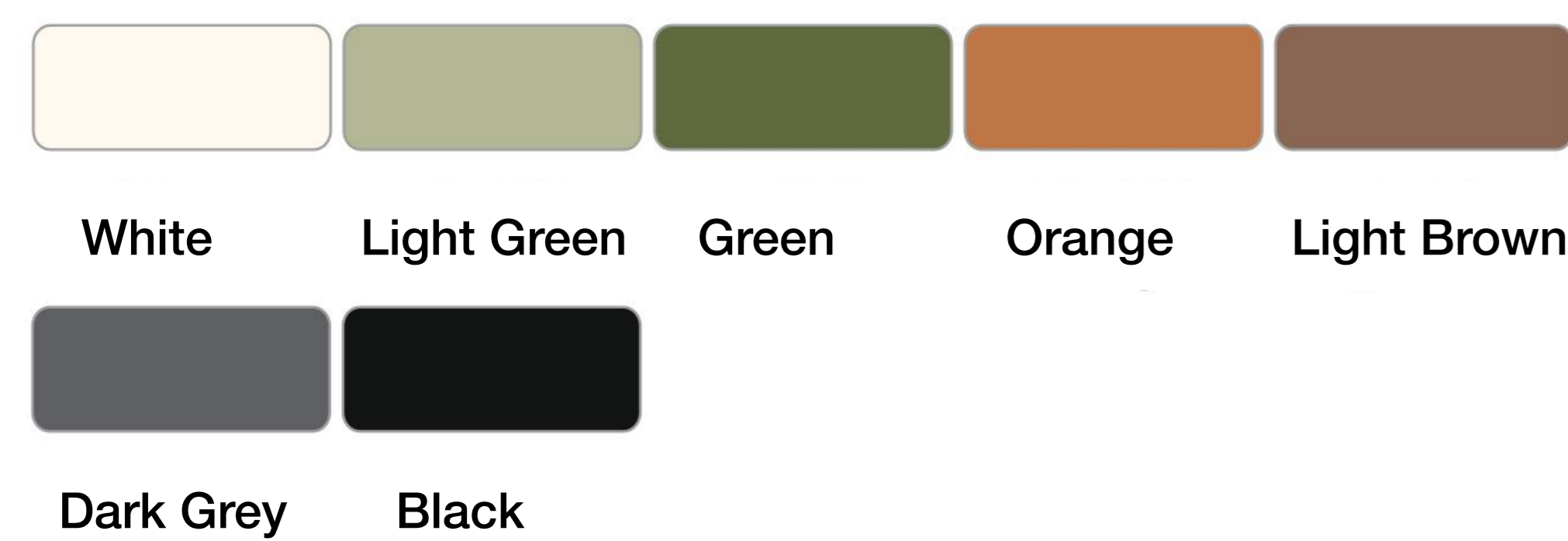

Name: DQ Medium Frequency Absorber

Models: F300M

Base Material: Polymer / Polyether polyol fire retardant acoustic foam

Finish: E0 Eco-friendly water based paint

Eco-Friendly: Zero Formaldehyde emission, E0 standard

Weight: ~ 1.6 Kg / pcs

Size: H1200*W300*D100mm

Acoustic structure:

A half concealed cavity structure that is formed polymer material and the U type Polyether polyol acoustic foam, forming a cavity that specialized to deal with low frequency sound of 300-800Hz

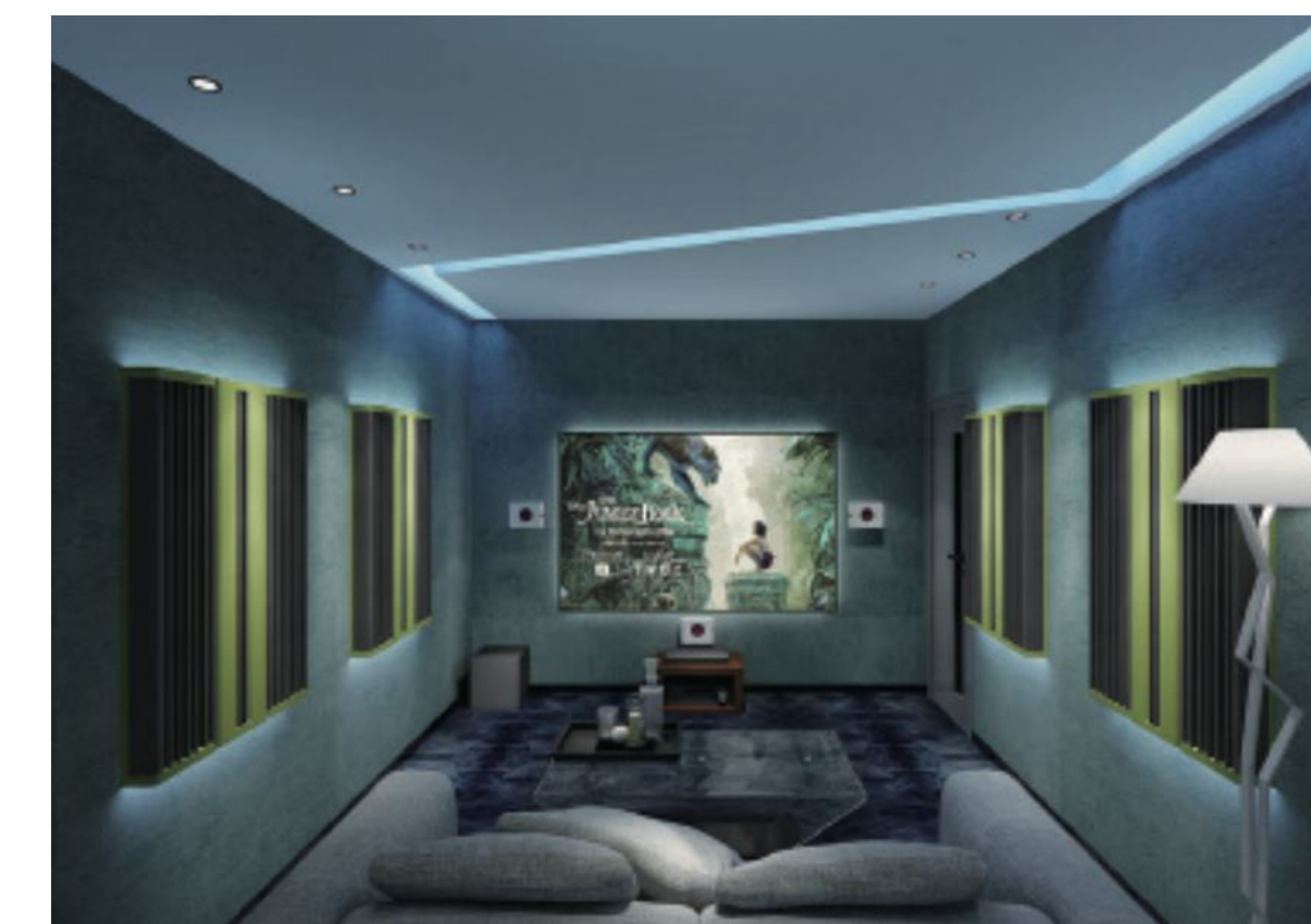
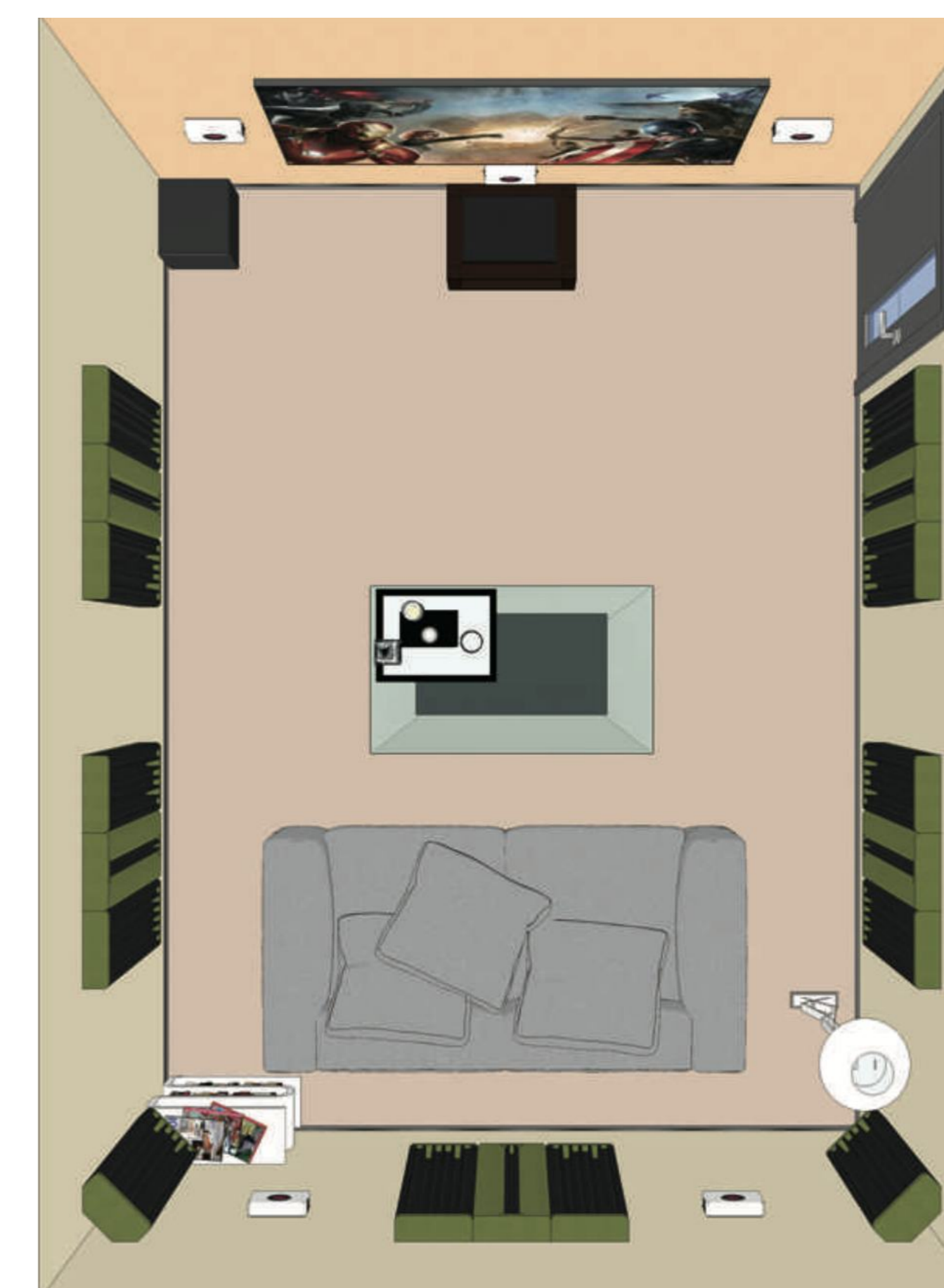
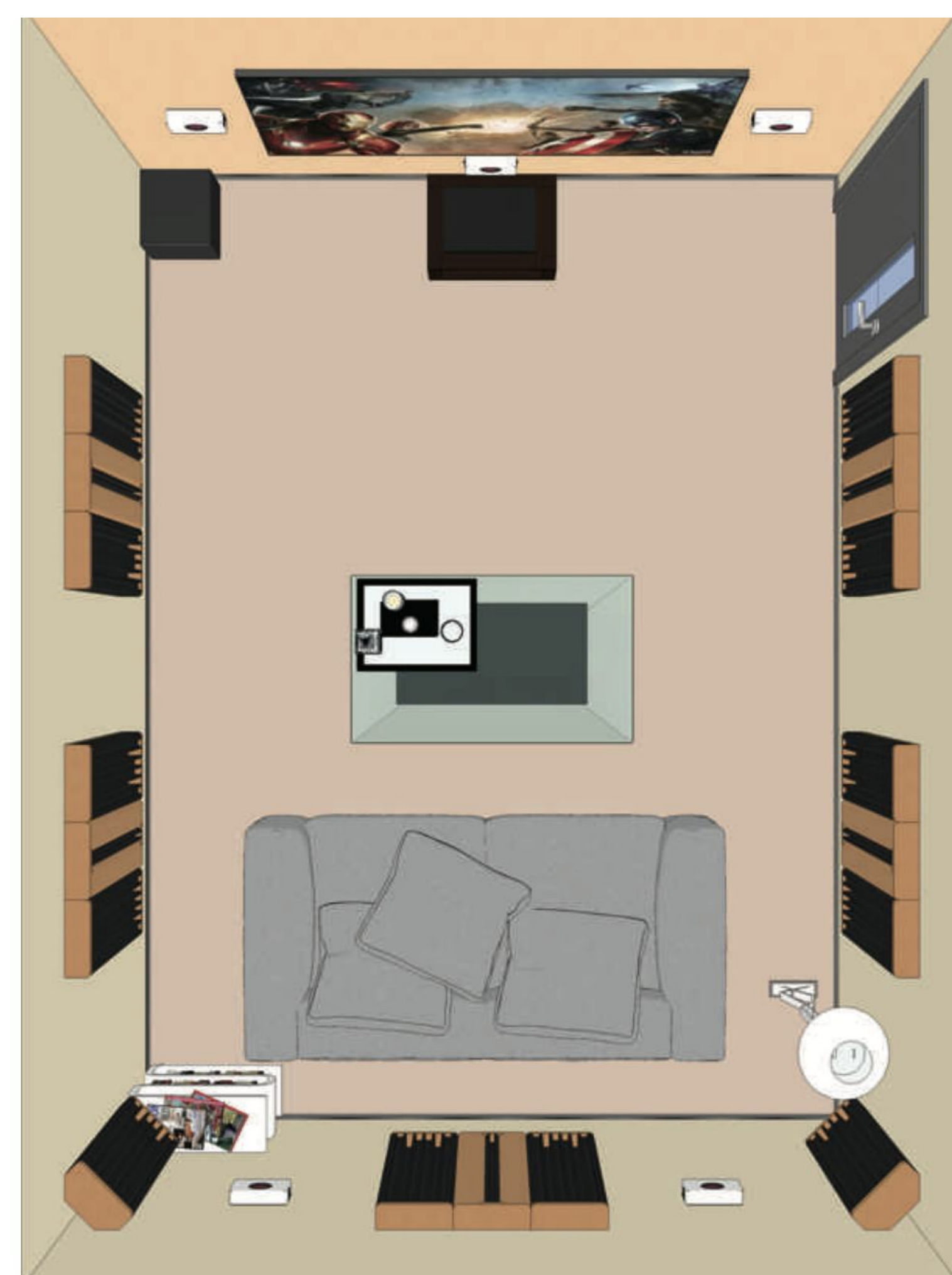
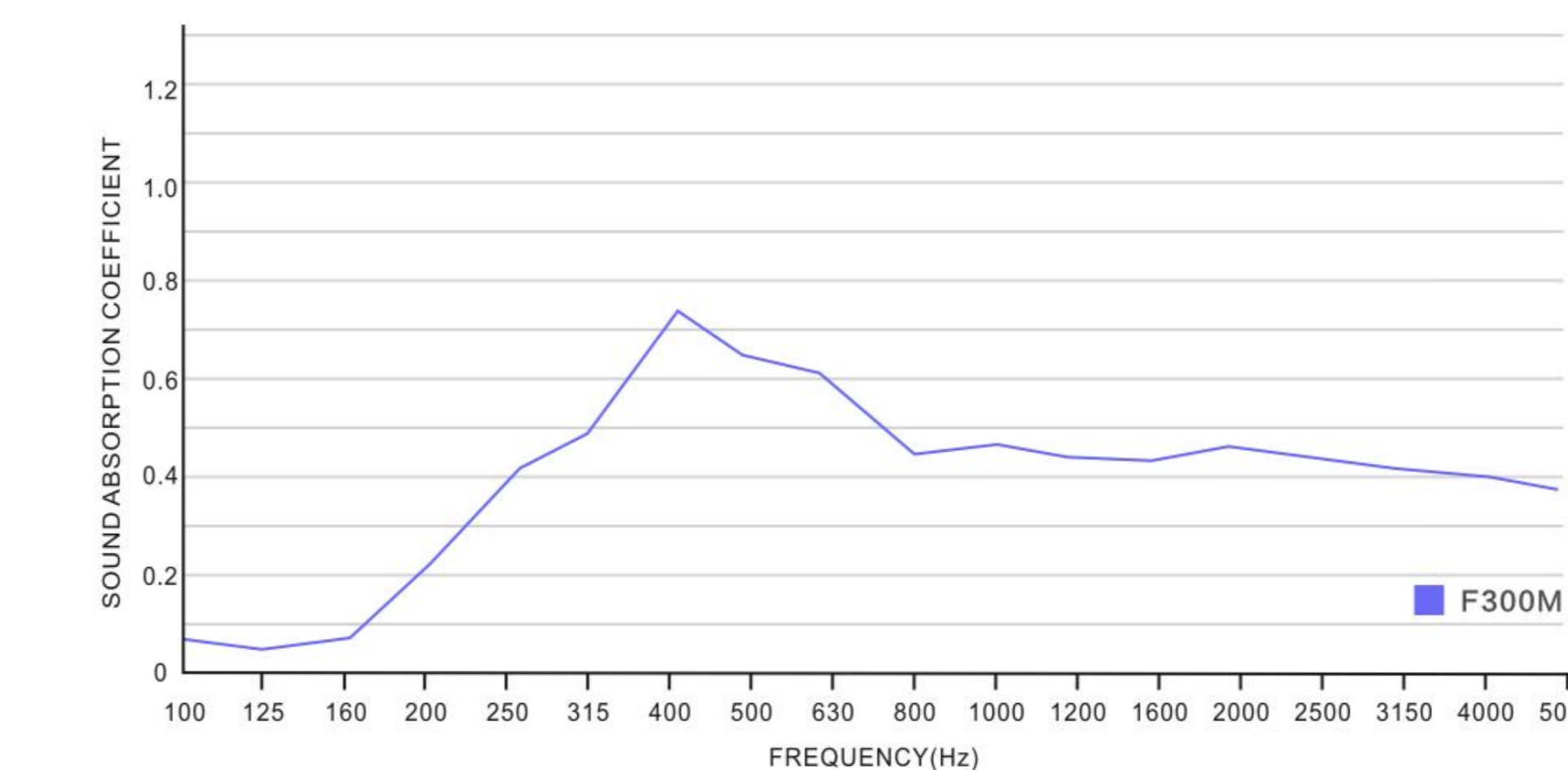
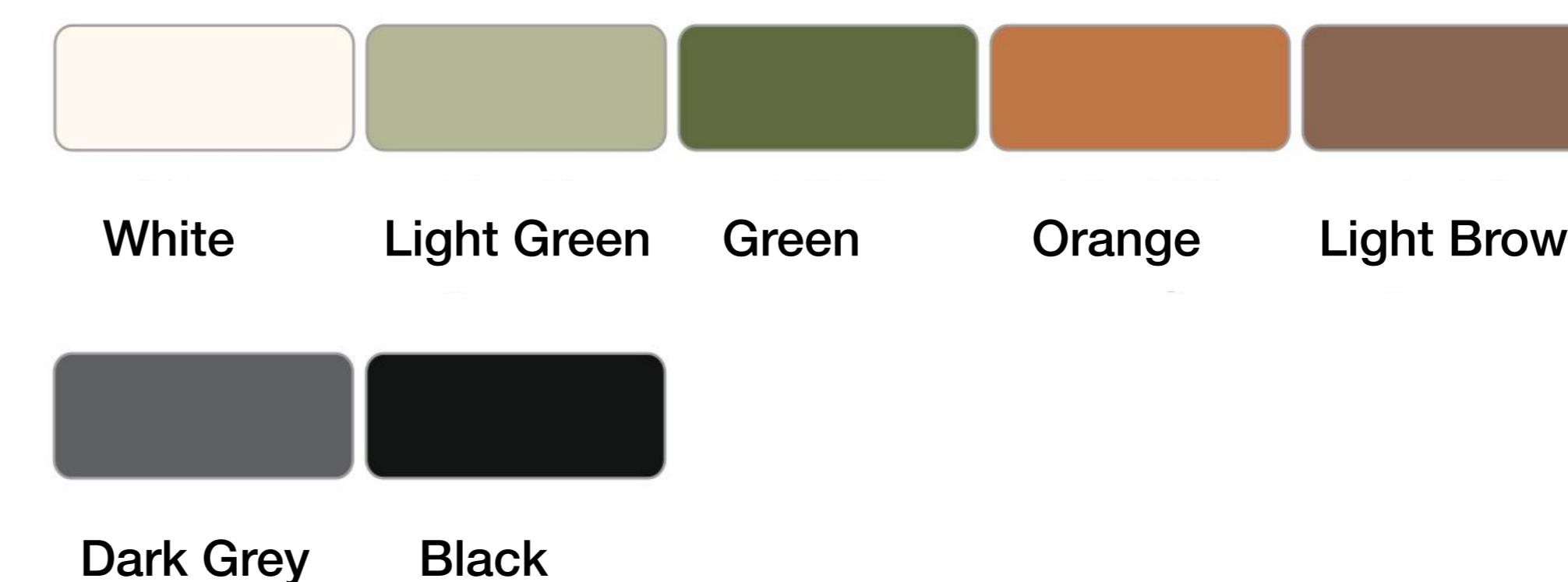

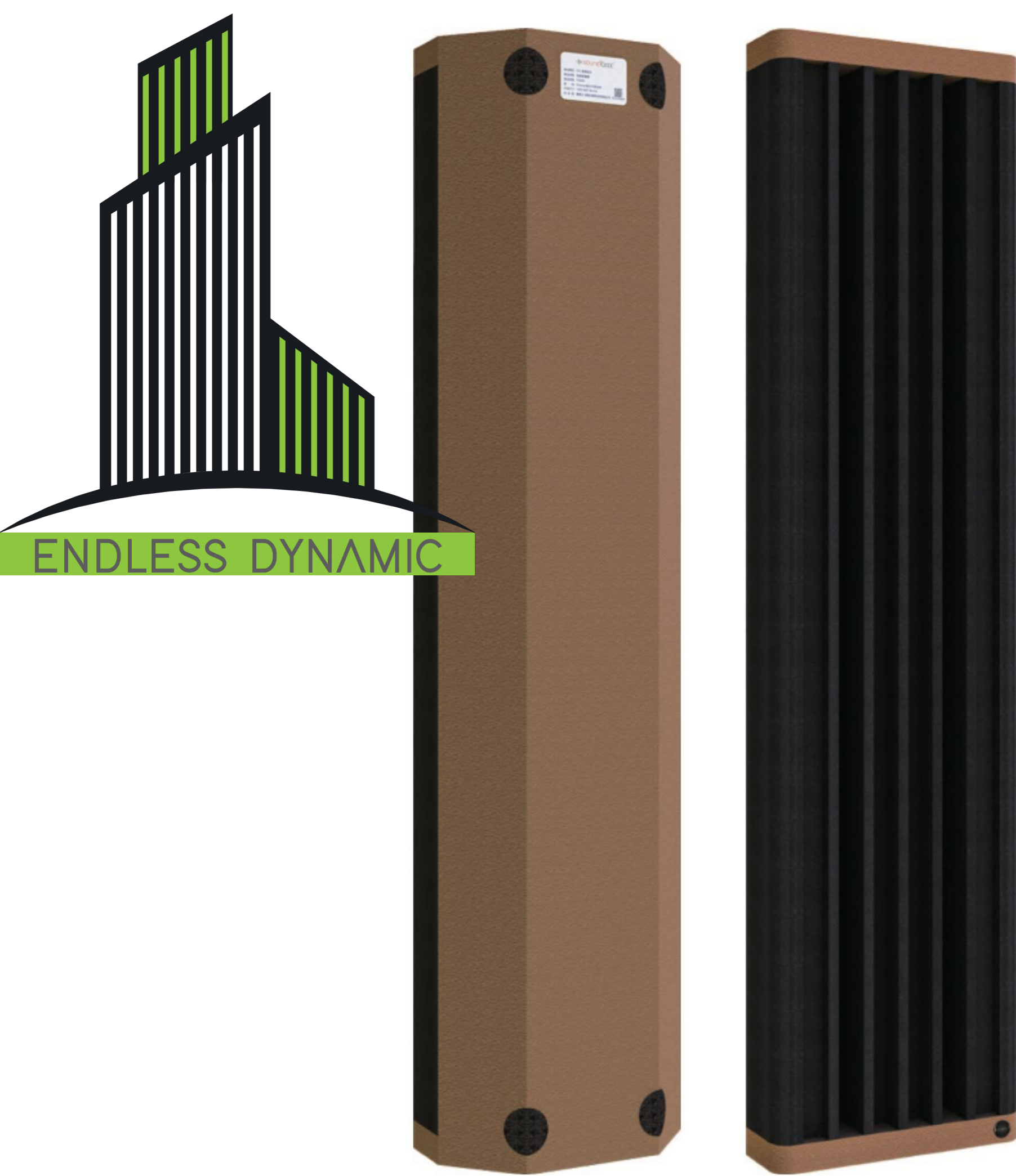

Name: DQ Low Frequency Absorber

Models: F300W

Base Material: Polymer / Polyether polyol fire retardant acoustic foam

Finish: E0 Eco-friendly water based paint

Eco-Friendly: Zero Formaldehyde emission, E0 standard

Weight: ~ 1.6 Kg/pcs

Size: H1200*W300*D150mm

Acoustic structure:

High density Polyether polyol acoustic foam improves sound absorption; QRD array and in-coordinated back cavity structure can achieve certain low frequency absorption. A balanced acoustic environment will be obtain via suitable products combination

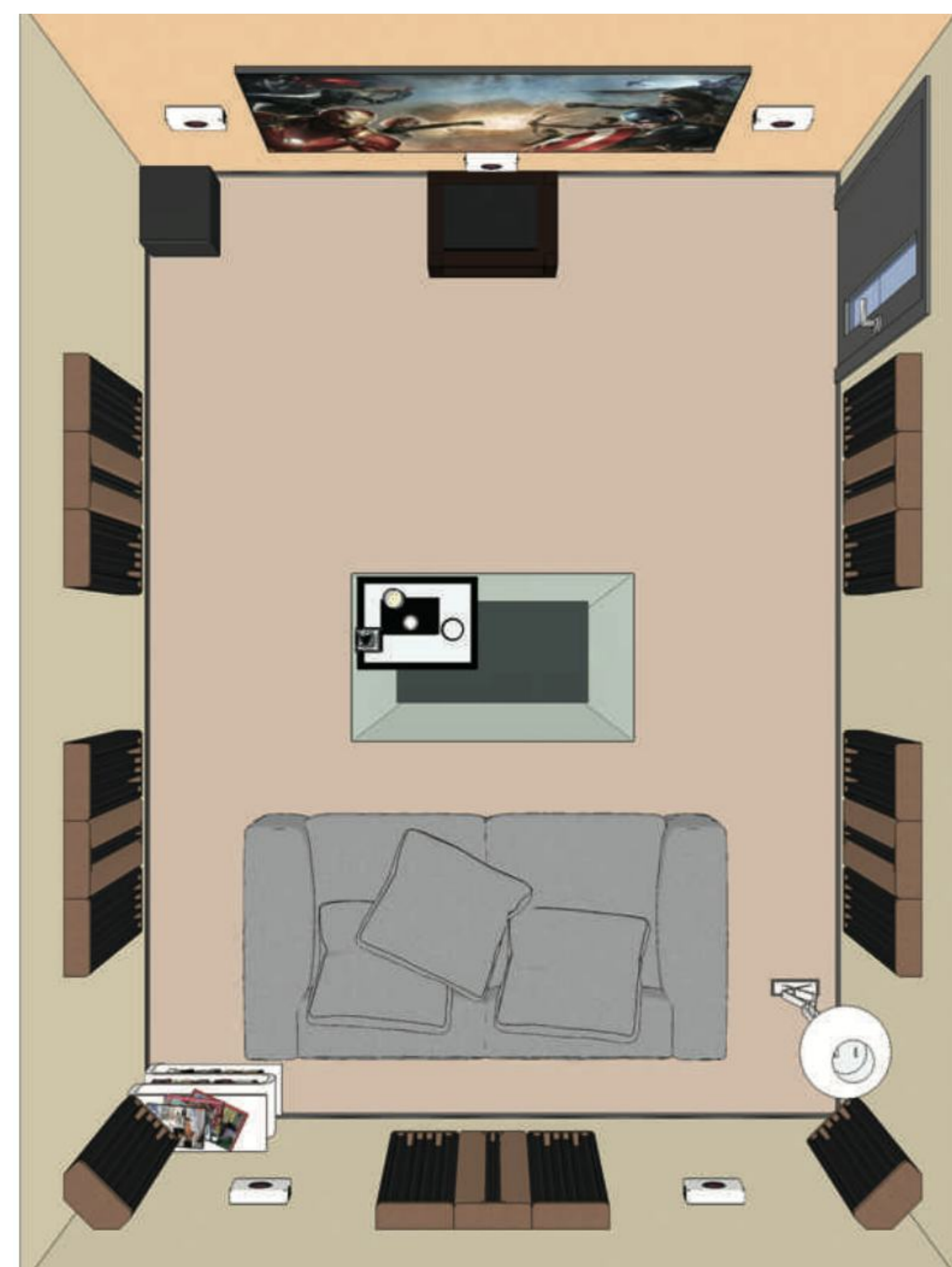
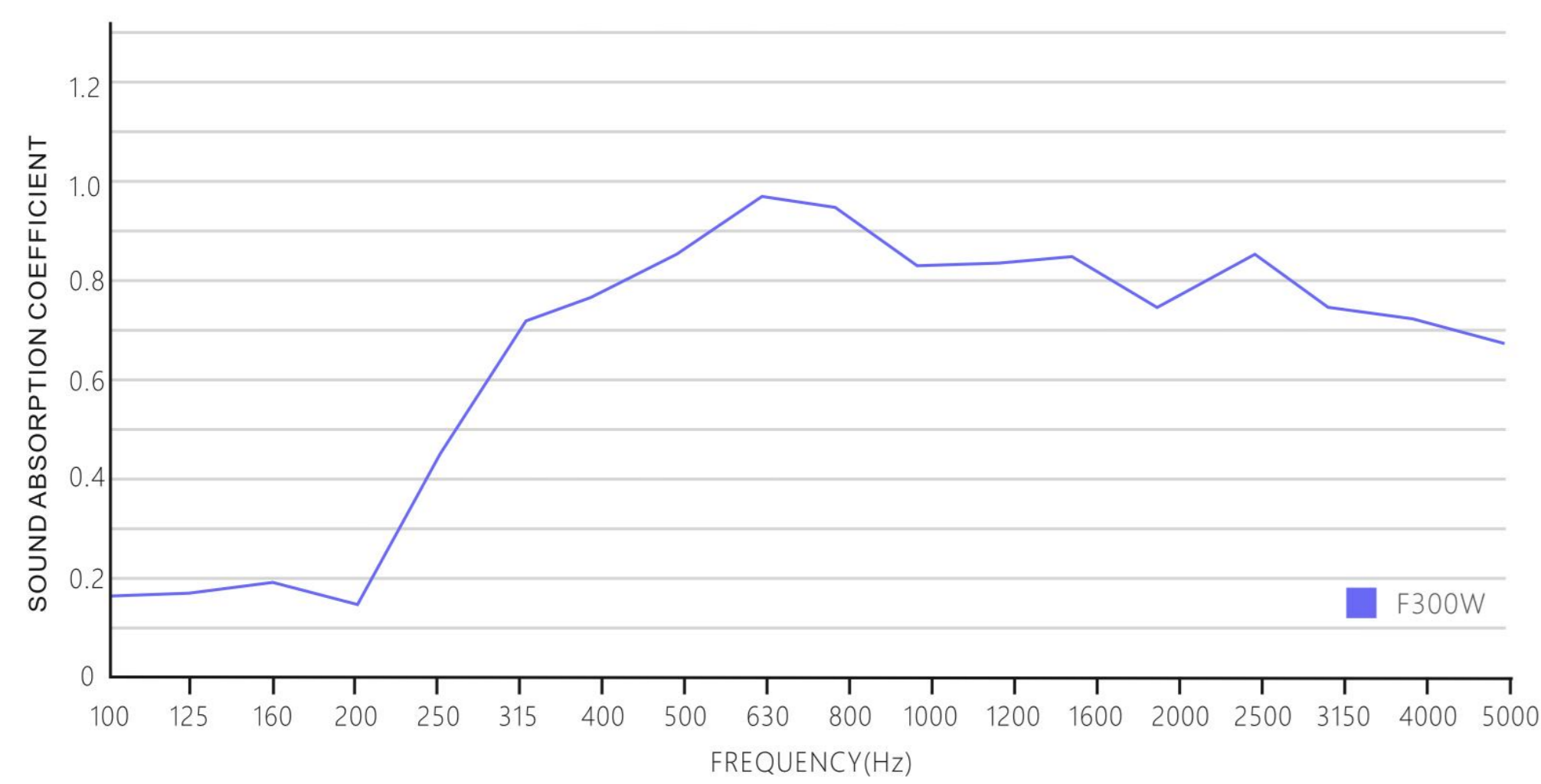
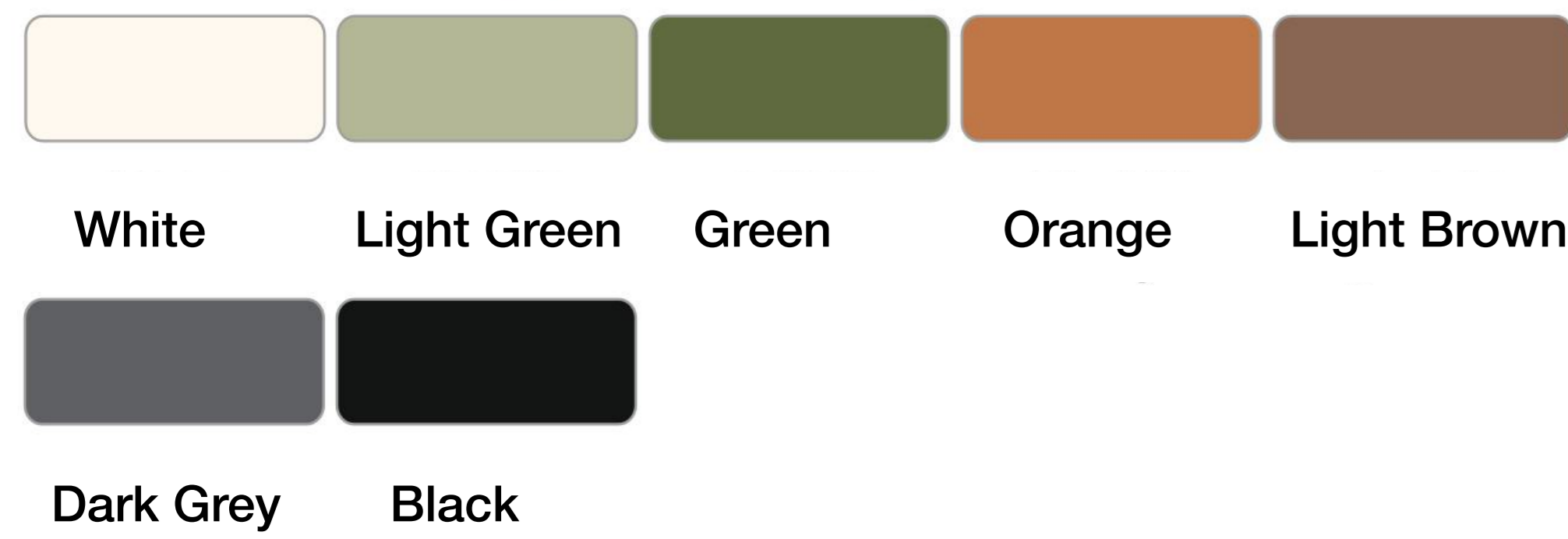

Name: DQ Full Band Frequency Diffuser

Models: F300D

Base Material: Polymer, chemical compound with large molecules

Finish: E0 Eco-friendly water based paint

Eco-Friendly: Zero Formaldehyde emission, E0 standard

Weight: ~ 2.8 Kg/pcs

Size: H1200*W300*D100mm

Acoustic structure:

Combining high tensile inorganic polymer coating, it will satisfy our stringent technical requirement from design on diffusion frequency and density of materials. At the same time, we are able to decrease product weight by eliminating defects of traditional materials. QRD array plays diffusion role effectively. When bettering sound dryness in small rooms, it improves sound fullness and surrounding sense without hurting natural reverberation.

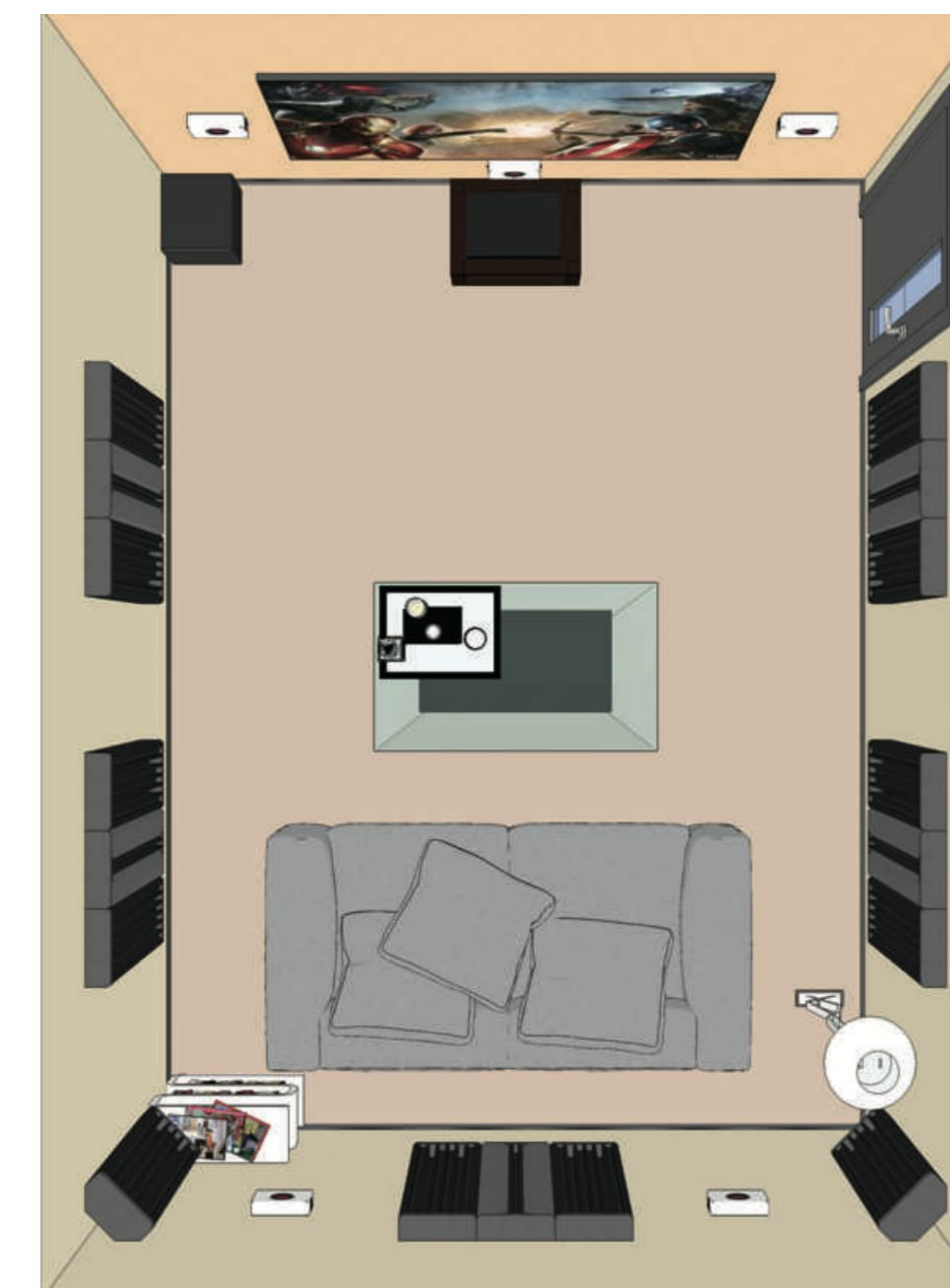
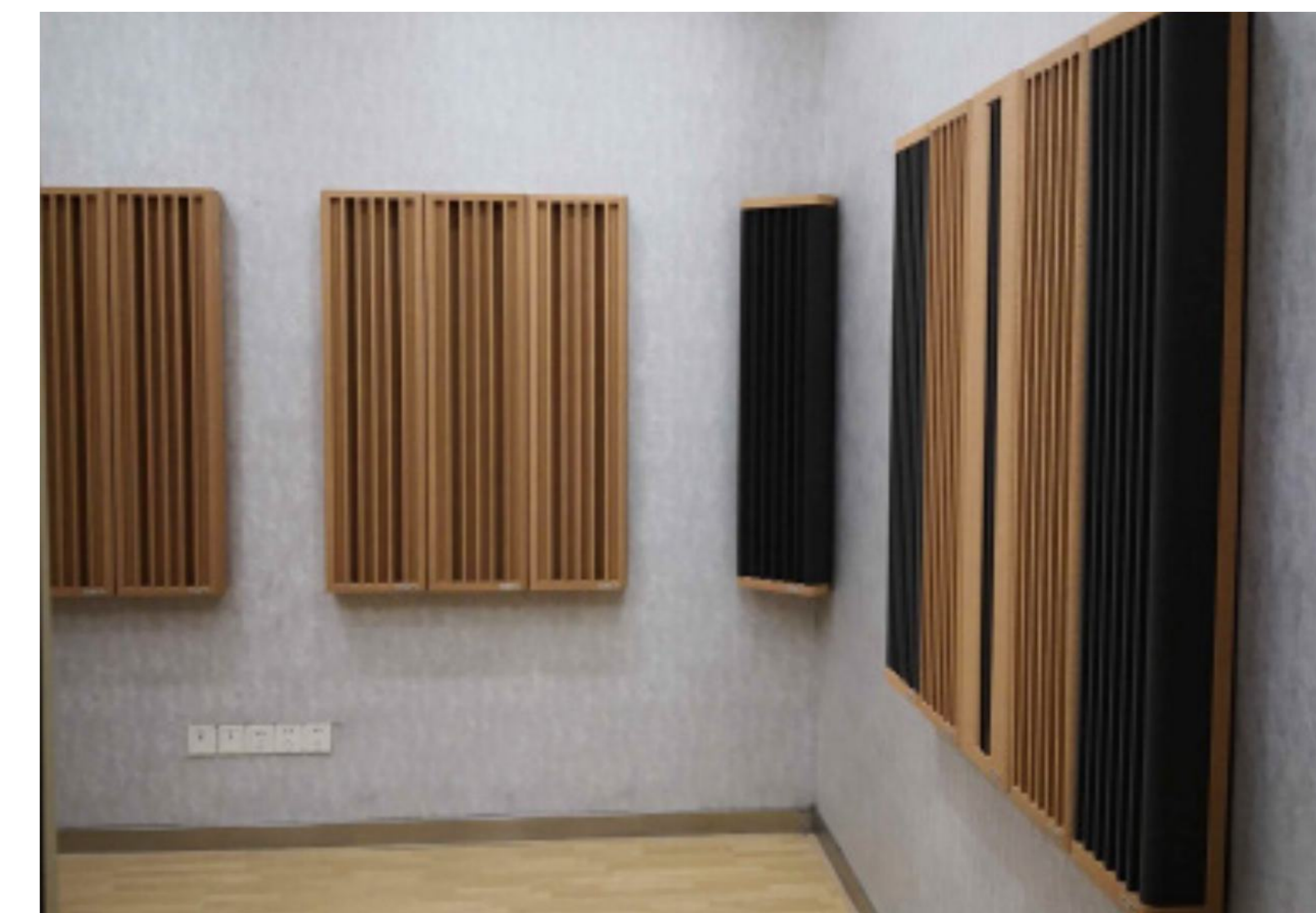
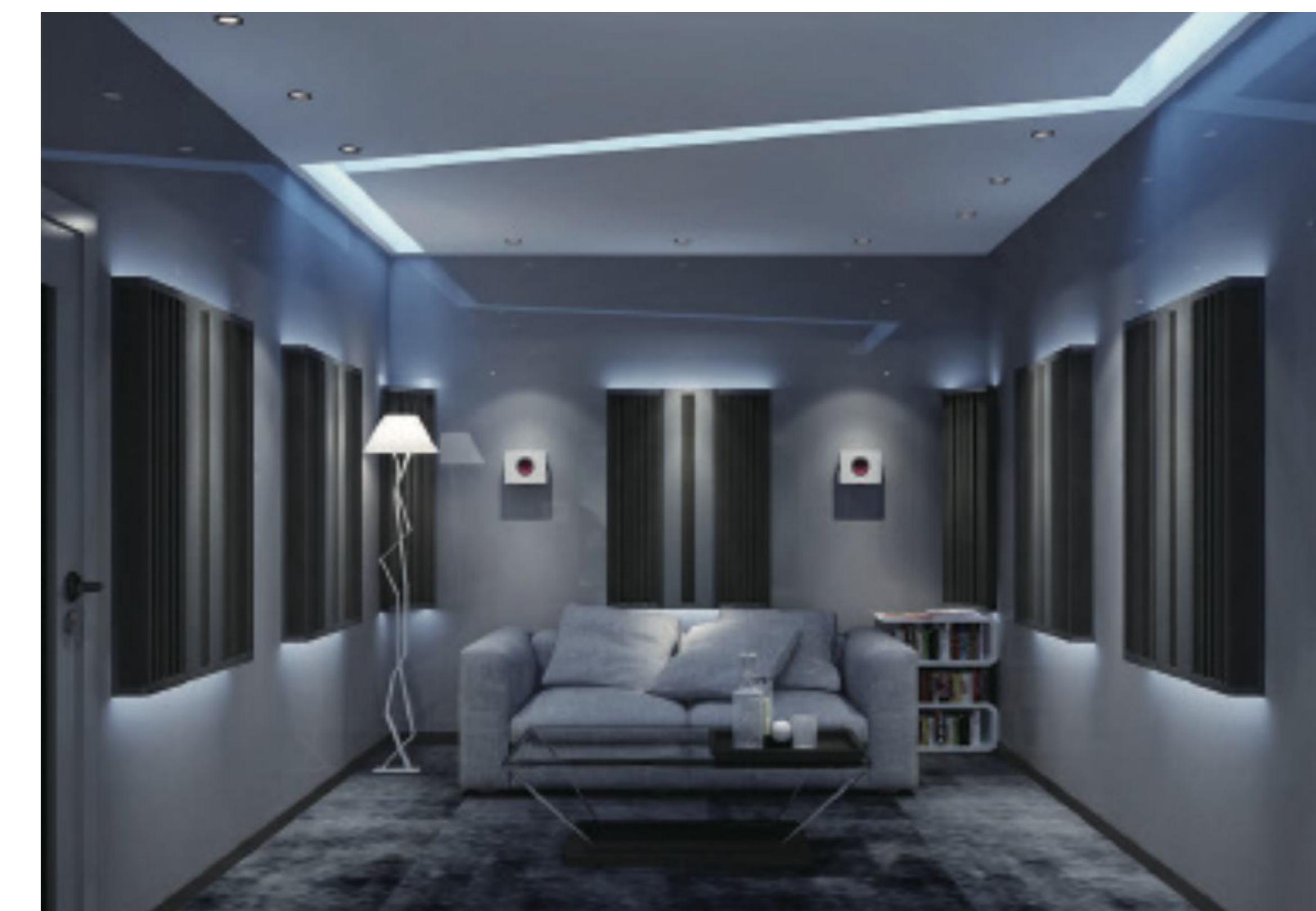
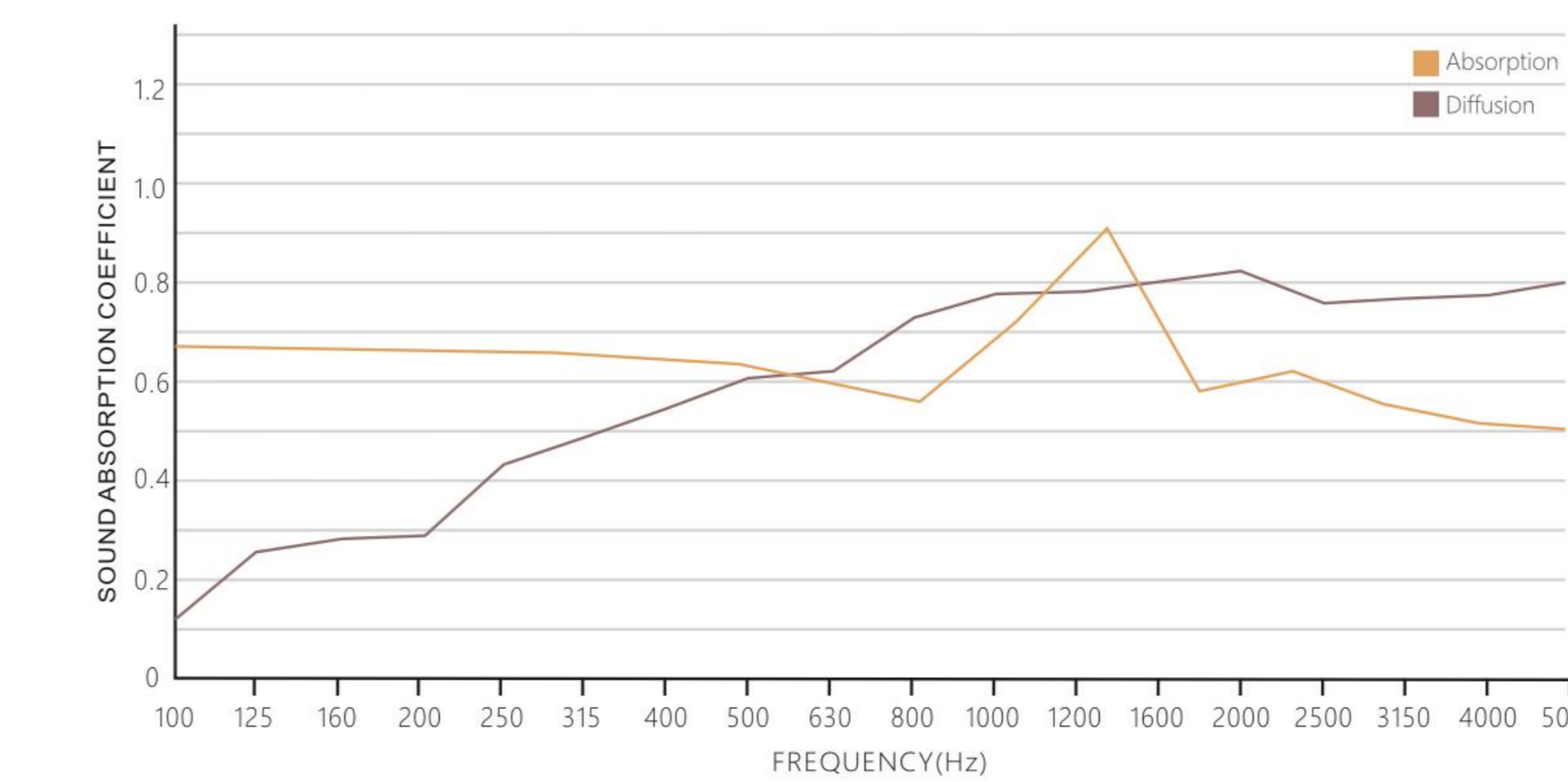
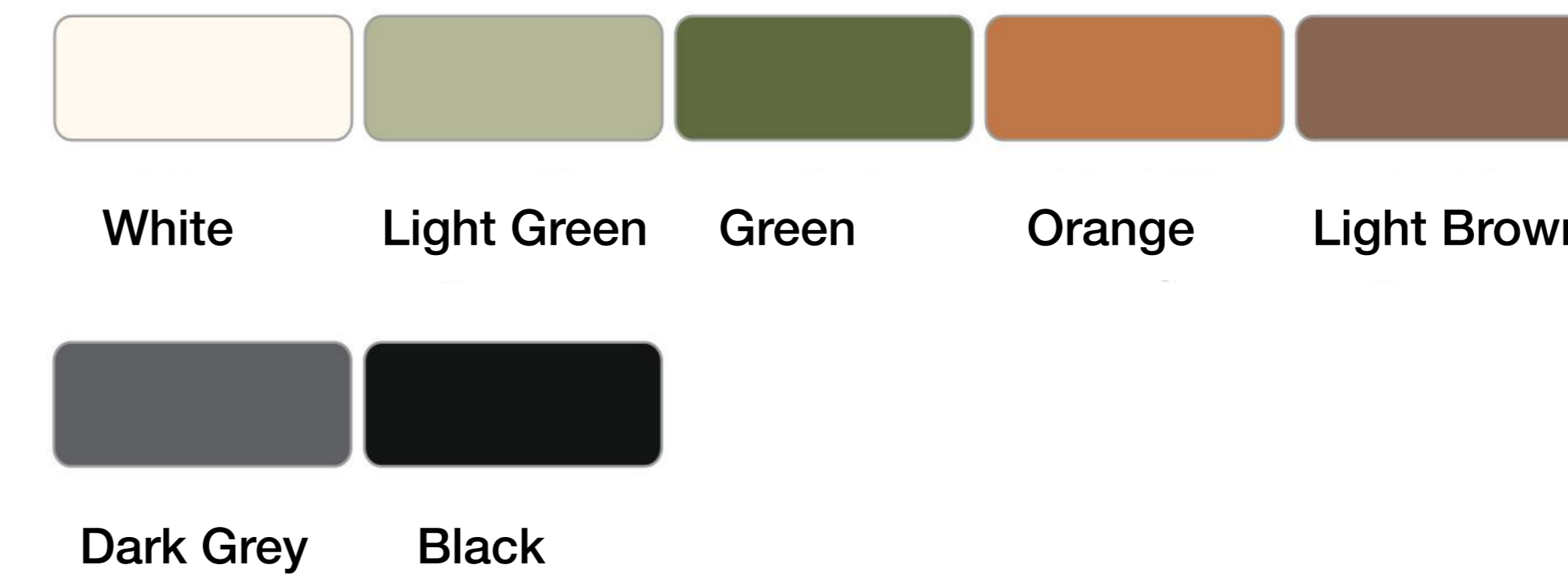



Name: DQ Cylinder Basstrap

Models: R300W / R350W

Base Material: Polymer, chemical compound with large molecules

Finish: E0 Eco-friendly water based paint

Eco-Friendly: Zero Formaldehyde emission, E0 standard

Weight: R300W ~ 2.8 Kg/pcs, R350W ~ 3.5 Kg/pcs

Size: R300W: r150 * H1200mm, R350W: r175 * H1200mm

Acoustic structure:

Combining high tensile inorganic coating, they are formed by pouring Polymer materials which is with good low absorption character, decreasing weight and overcome traditional drawbacks.

Adopting the wise open resonance box model, it is the one of the effective approaches to capture 100-250Hz, taming most of problems caused by excess of low frequencies.

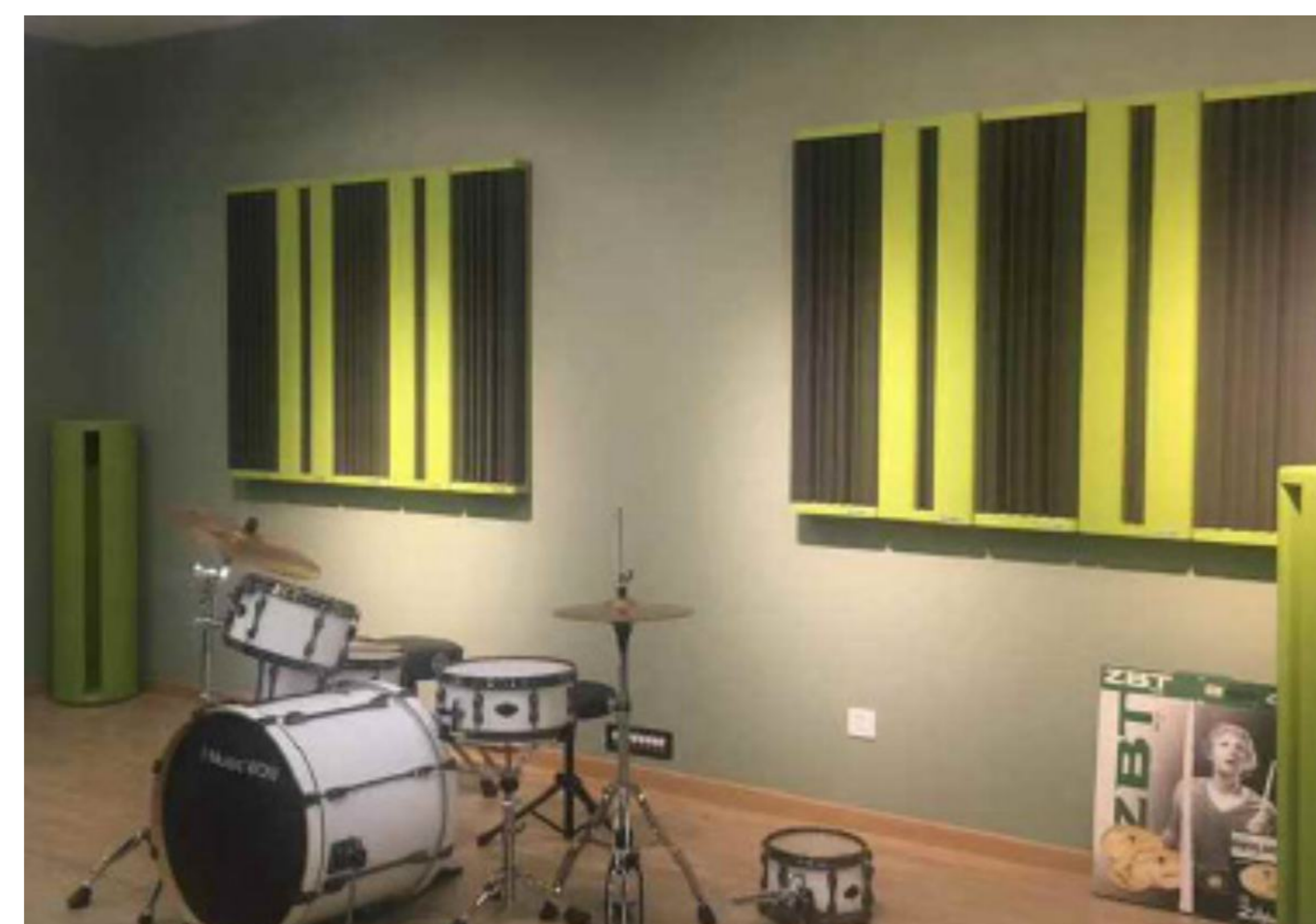
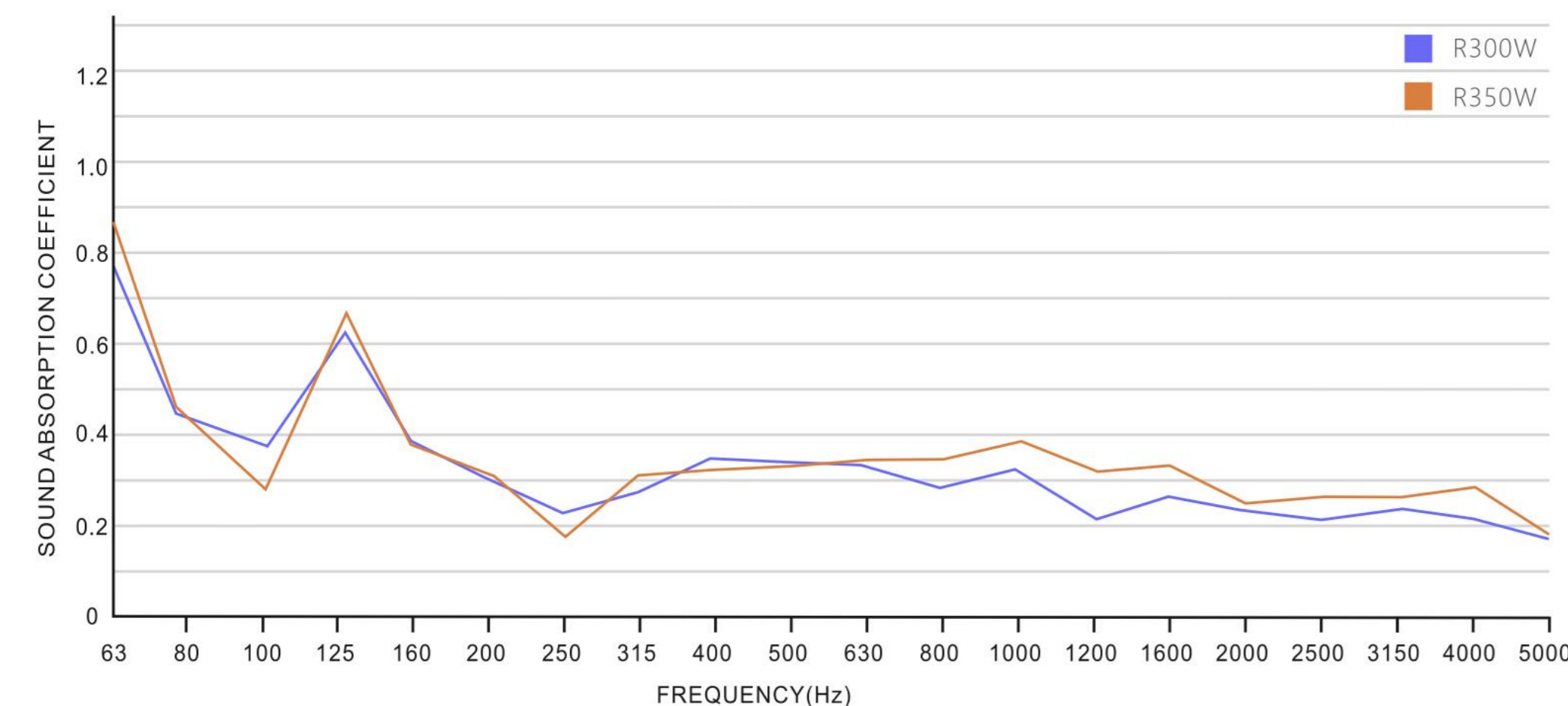
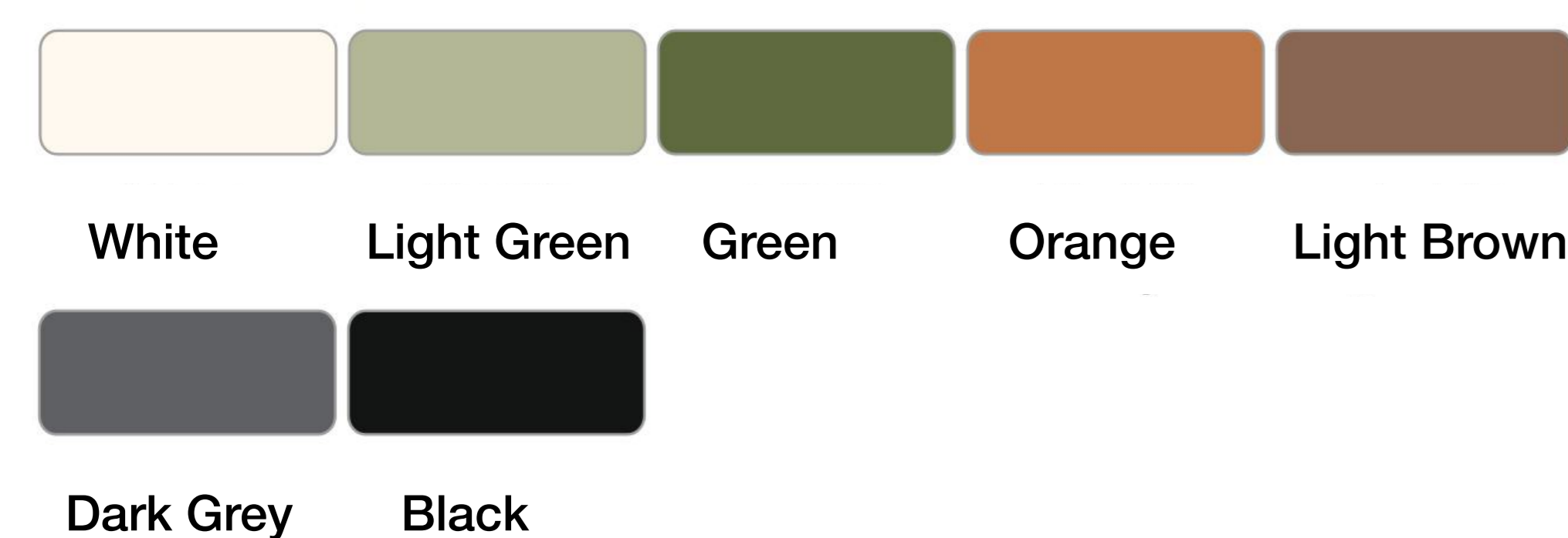

Name: DQ Corner Basstrap

Models: C300W / C350W

Base Material: Polymer, chemical compound with large molecules

Finish: E0 Eco-friendly water based paint

Eco-Friendly: Zero Formaldehyde emission, E0 standard

Weight: C300W ~ 2.8 Kg/pcs, C350W ~ 3.2 Kg/pcs

Size: C300W: H1200*W300*D300mm, C350W: H1200*W350*D350mm

Acoustic structure:

Combining high tensile inorganic coating, they are formed by pouring Polymer materials which is with good low absorption character, decreasing weight and overcome traditional drawbacks.

Adopting the wise open resonance box model, it is the one of the effective approaches to capture 100-250Hz, taming most of problems caused by excess of low frequencies.

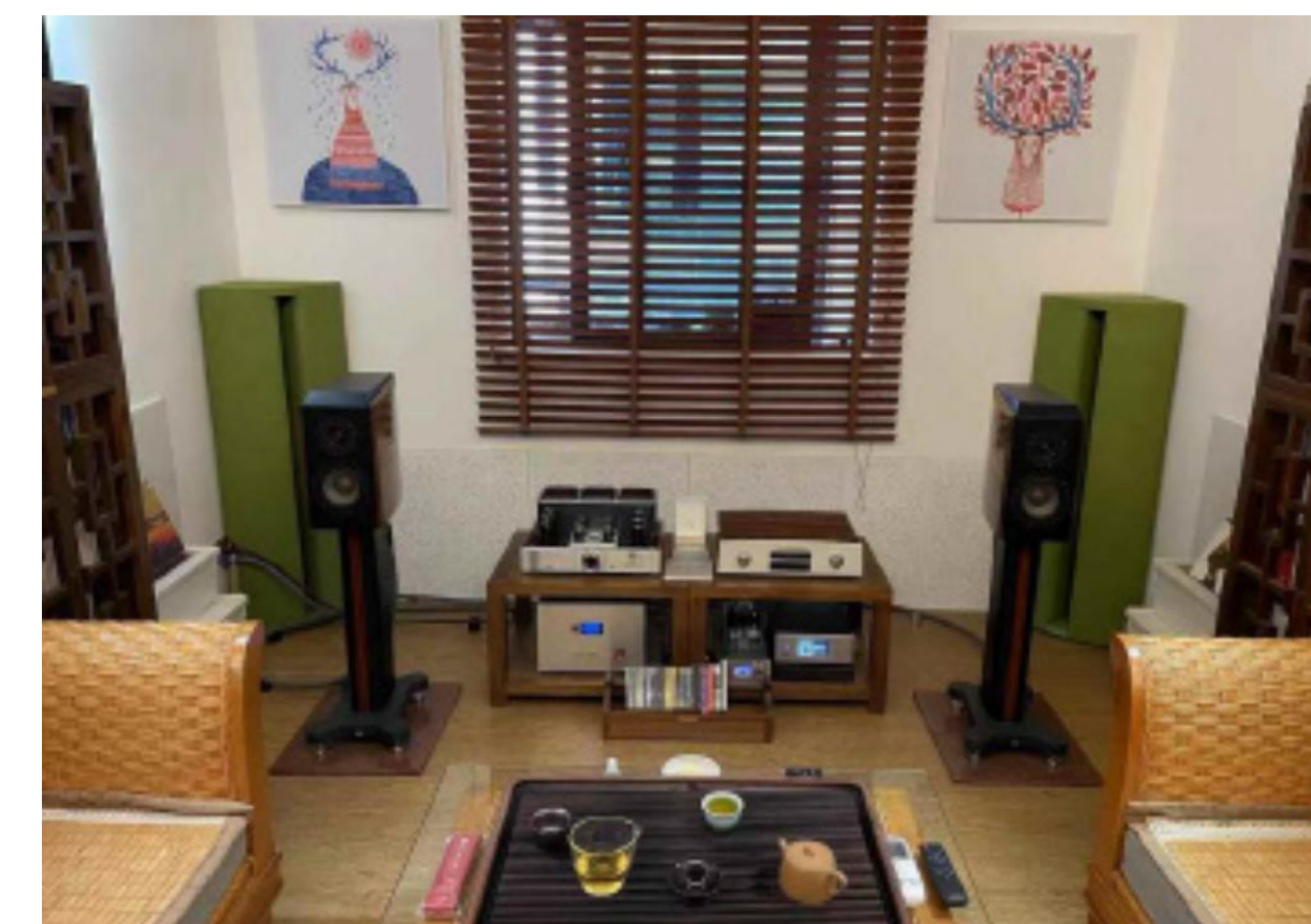
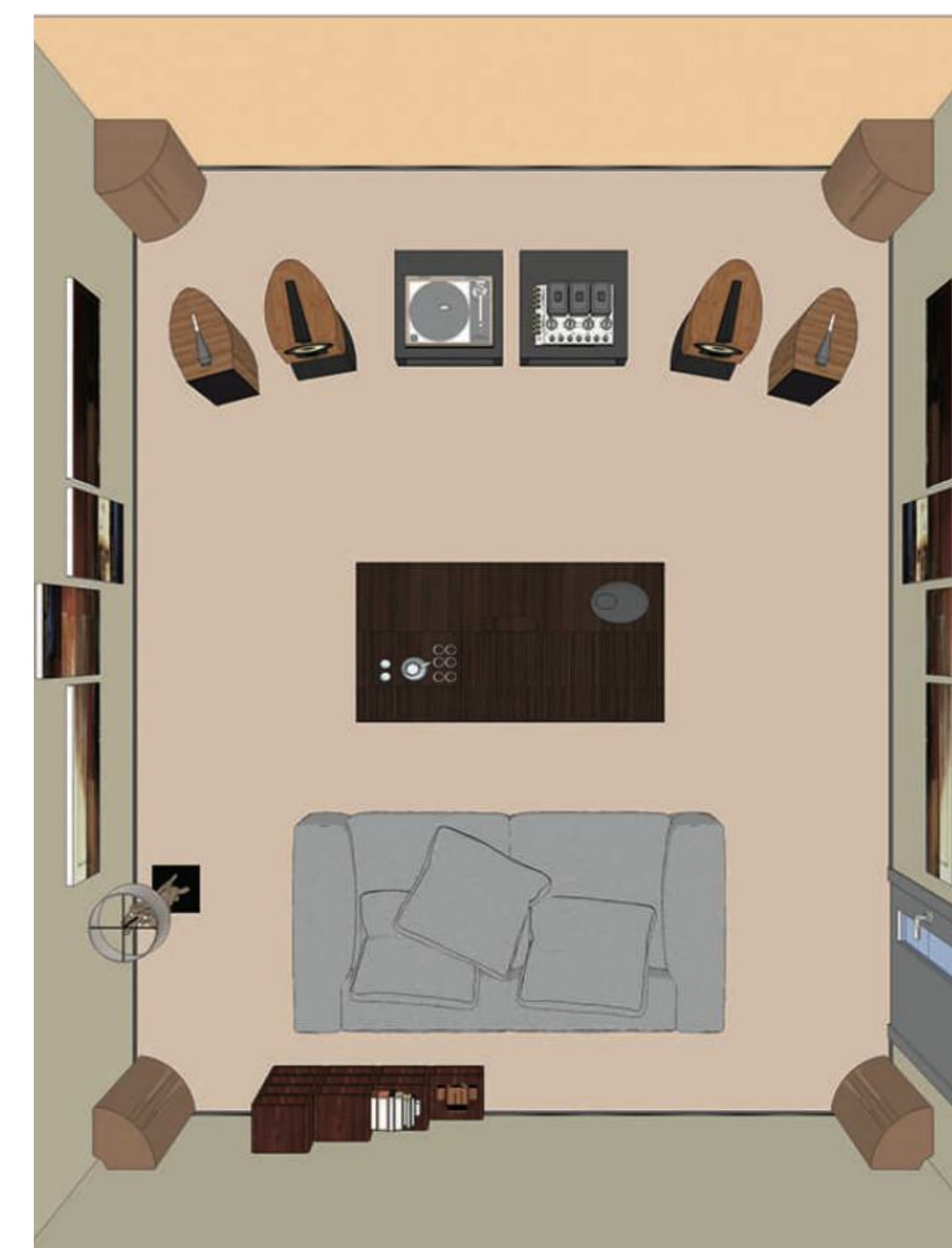
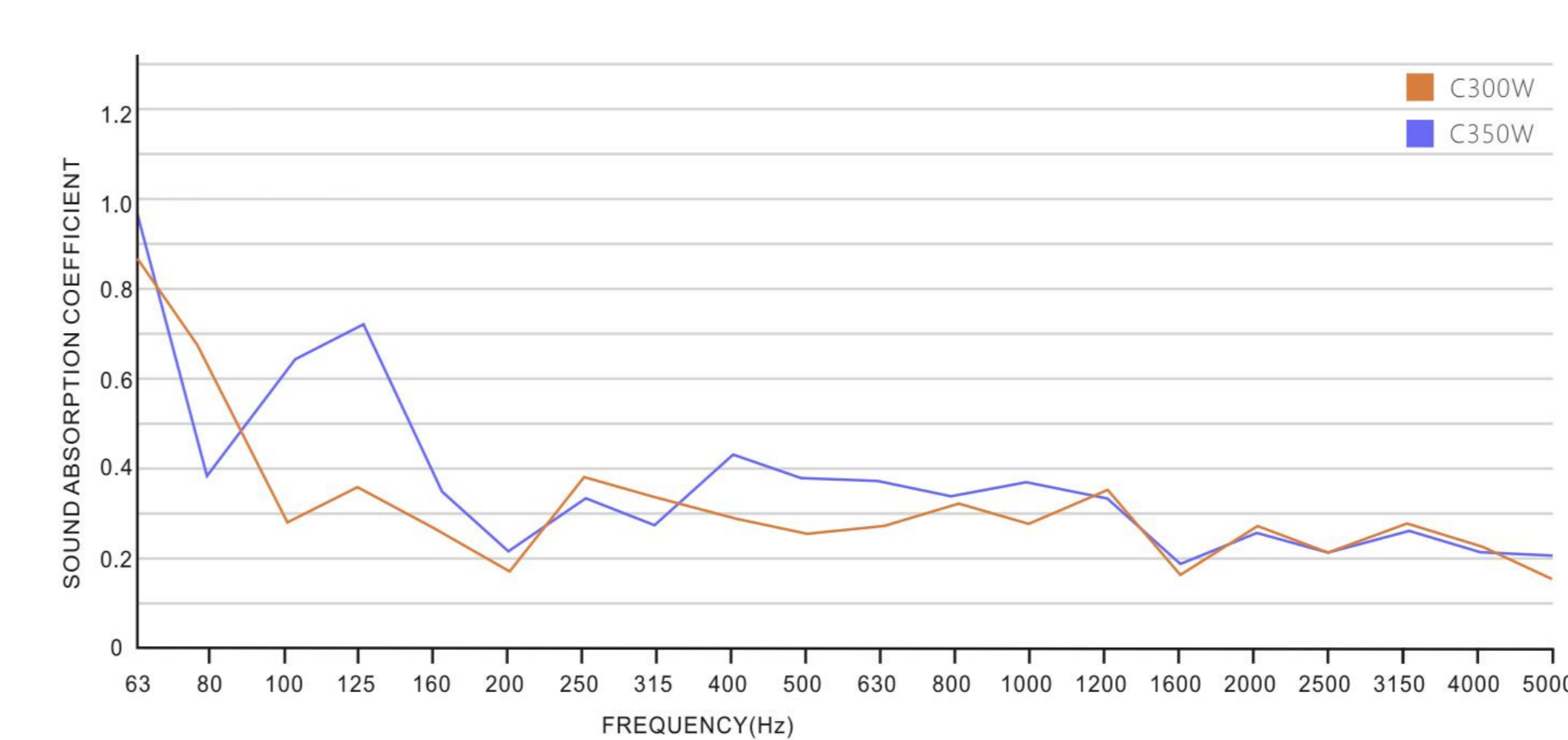
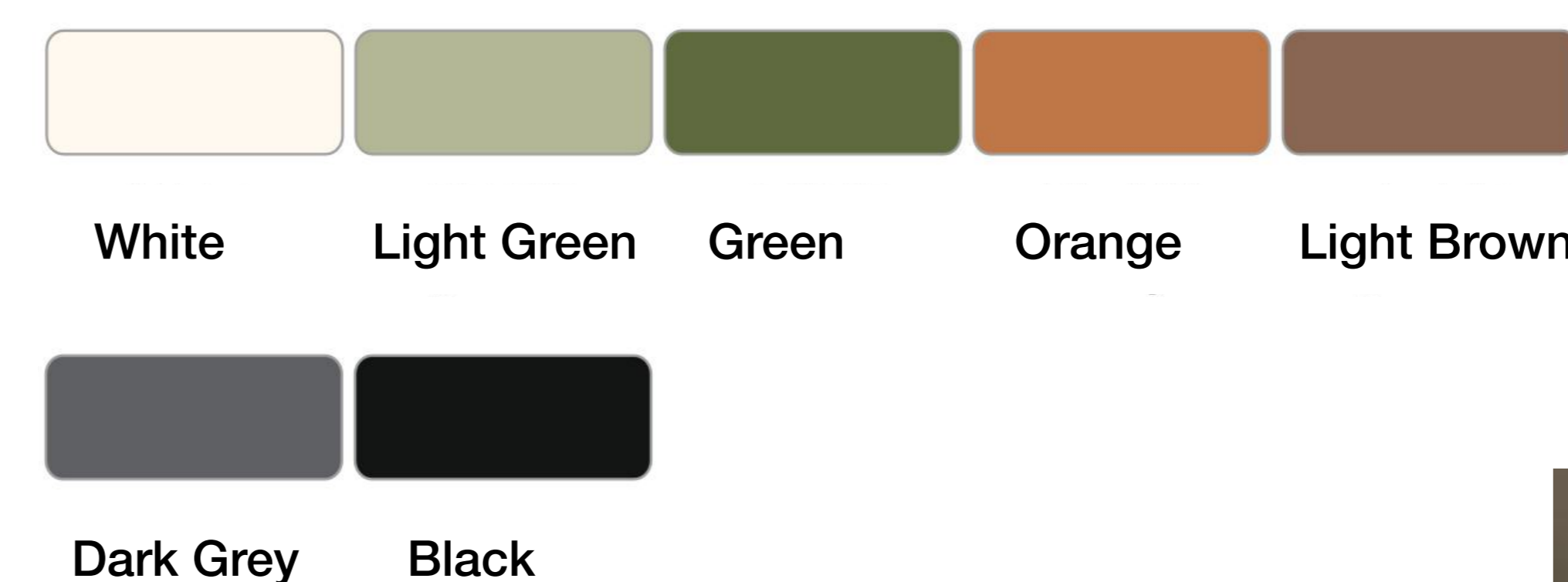



Name: Acoustic Baggle

Models: AQ1000S

Structure: Solid wood formation. Large version of QRD quadratic residue diffusion surface, three-step non-proportional cavity broadband sound absorption surface, labyrinth-type low-frequency trap with vibration damping base.

Eco-Friendly: E0 standard

Finish: SF1200 Acoustical fabric for sound absorption, Diffusion side: Solid wood (Refer to color chart for details)

Weight: 38 Kg

Size: H1600 *W600*D150/350mm

Optional: Movable roller accessories can be installed on the base (purchased separately).

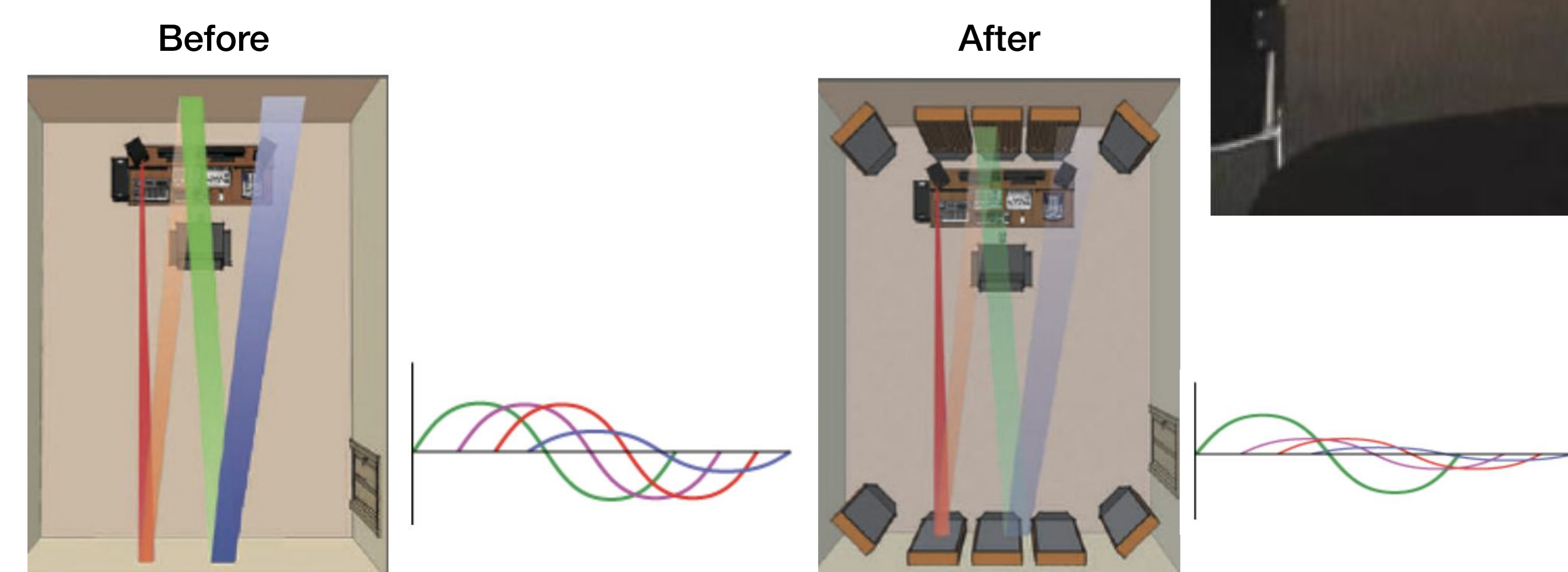
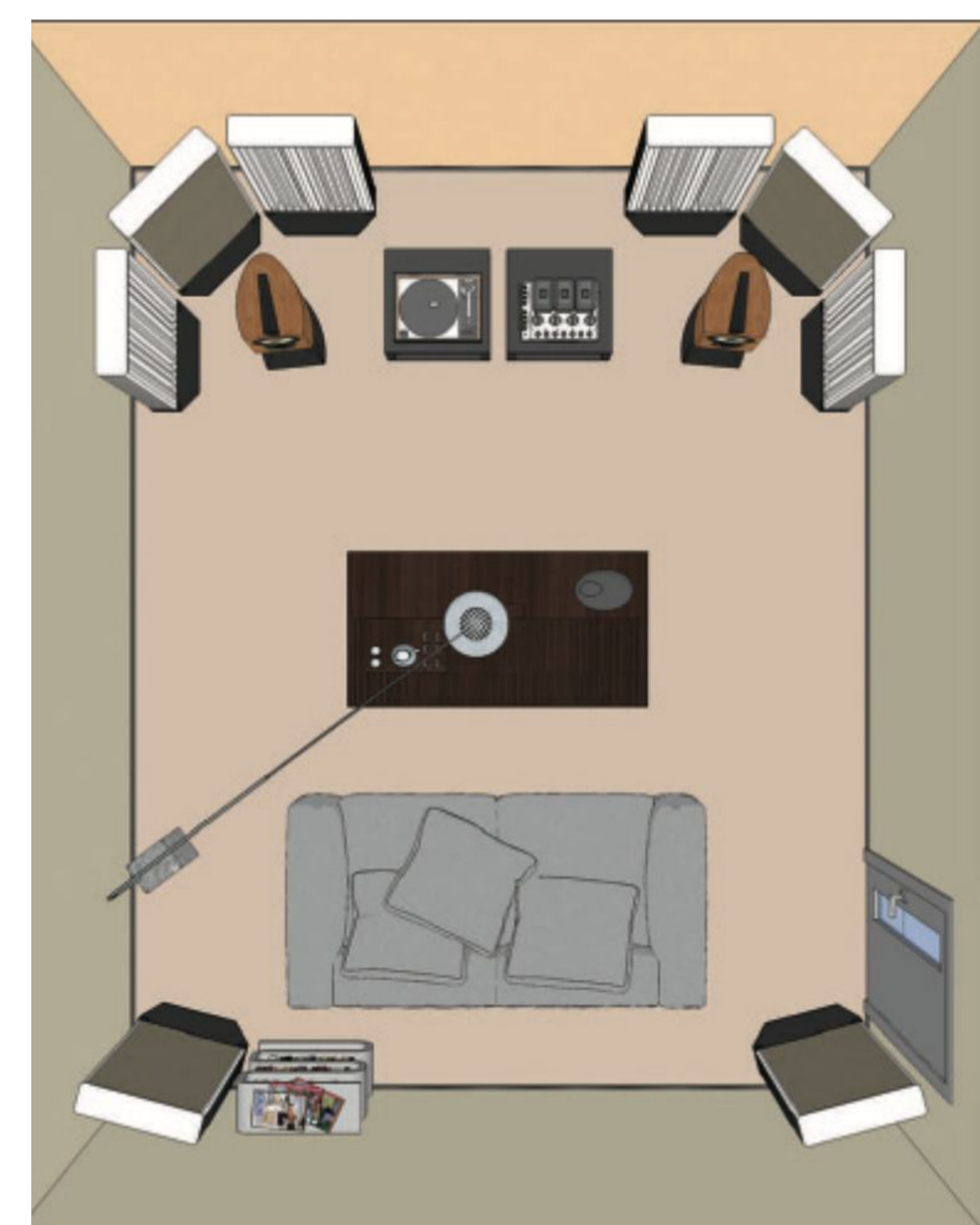
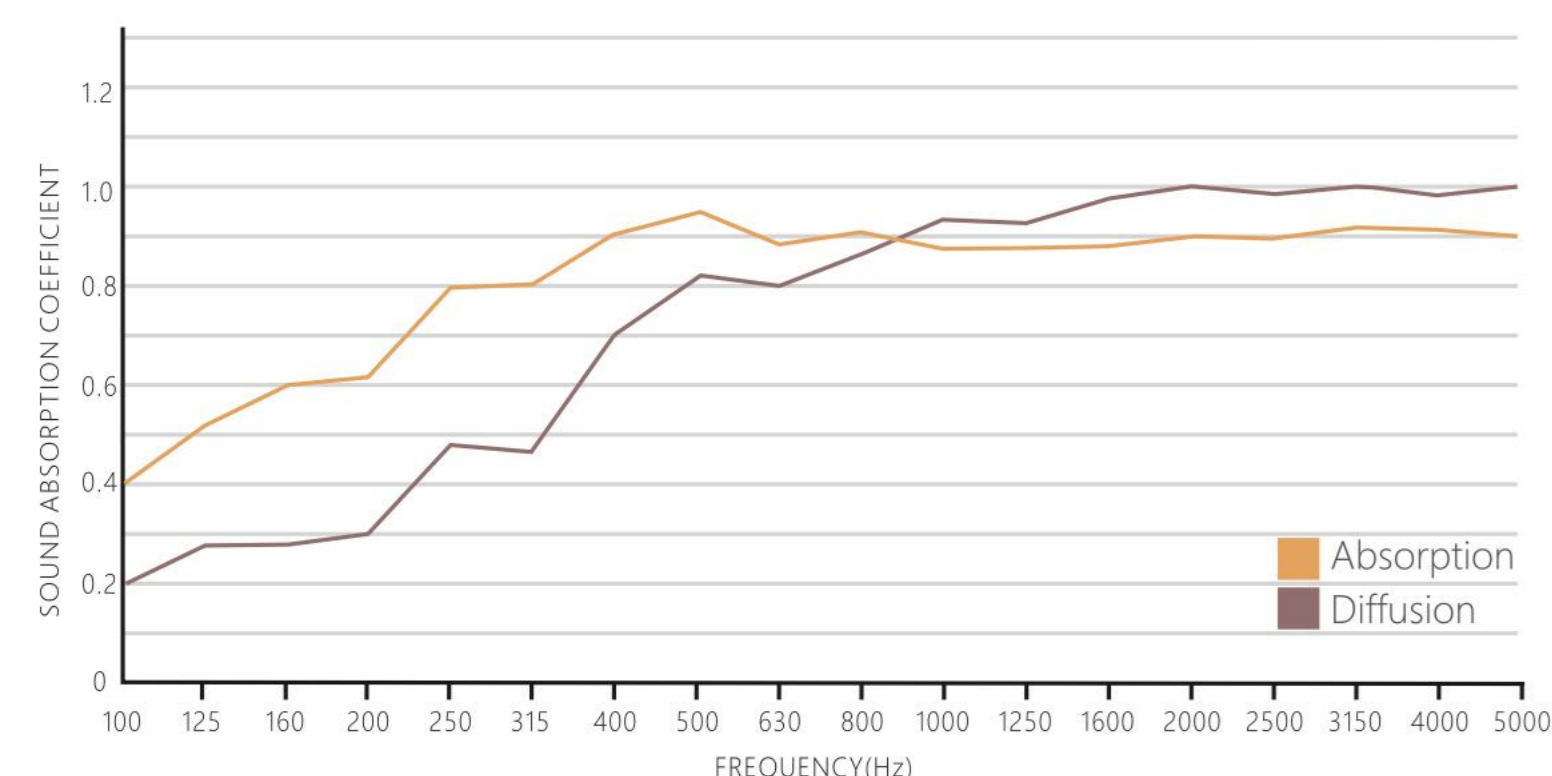
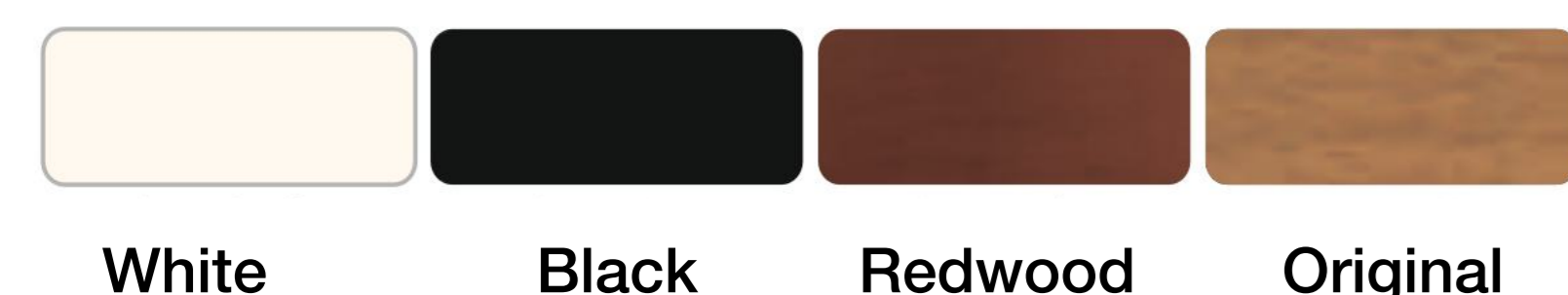

Application:

Suits for controlling reverberation time and standing waves at the corner in small rooms : listening rooms, studio and home theater. it does well in sound absorption and diffusion when sound is being reflected.

The most important goal of the room acoustic treatment is to establish a neutral listening space. Most of the residential or commercial rooms adopt the rectangular parallel walls. This means that those rooms will suffer from strong reflection, flutter echo, standing waves and resonance. AQ1000S will make a poor resonant room become a very practical space and will help to obtain the conditions for finishing the audio work.



Name: Haydn Acoustic Array

Models: AQ1000SL

Structure: Solid wood formation. Large version of QRD quadratic residue diffusion surface, three-step non-proportional cavity broadband sound absorption surface, labyrinth-type low-frequency trap with vibration damping base.

Eco-Friendly: E0 standard

Finish: SF1200 Acoustical fabric for sound absorption, Diffusion side: Solid wood (Refer to color chart for details)

Weight: 71 Kg

Size: H2400 *W600*D150/800mm

Application: Suits for bigger rooms- listening rooms, studio and home theater.

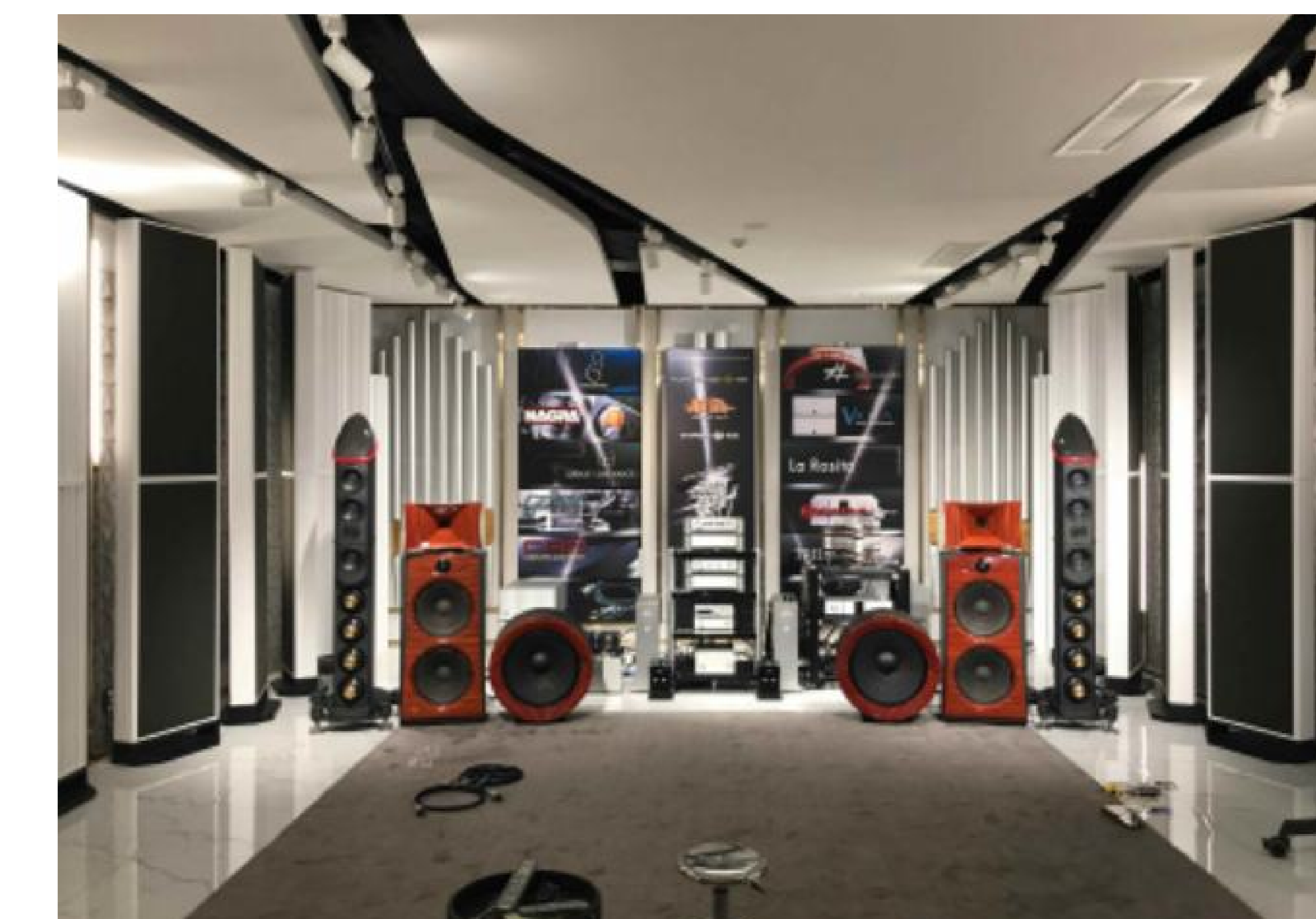
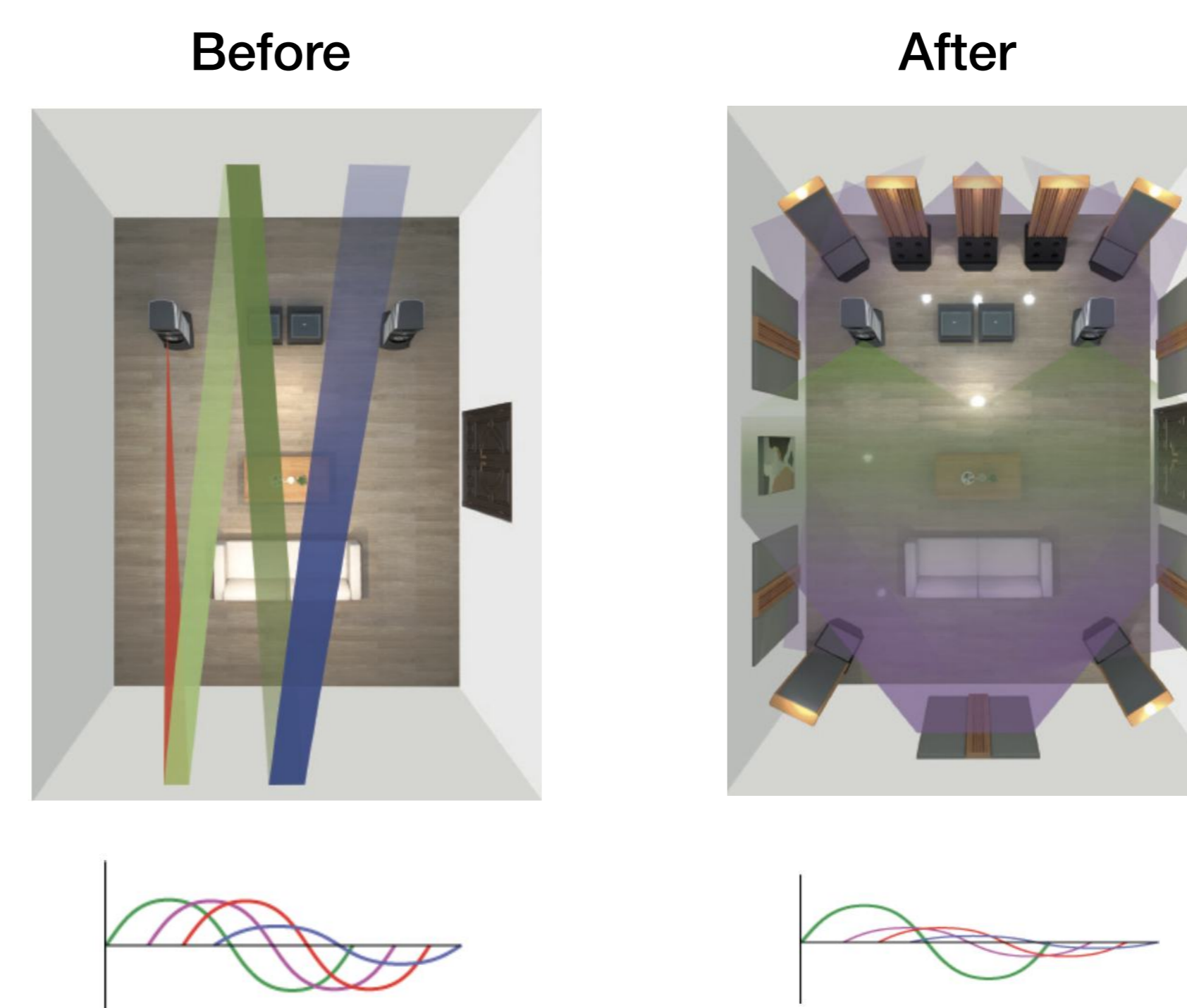
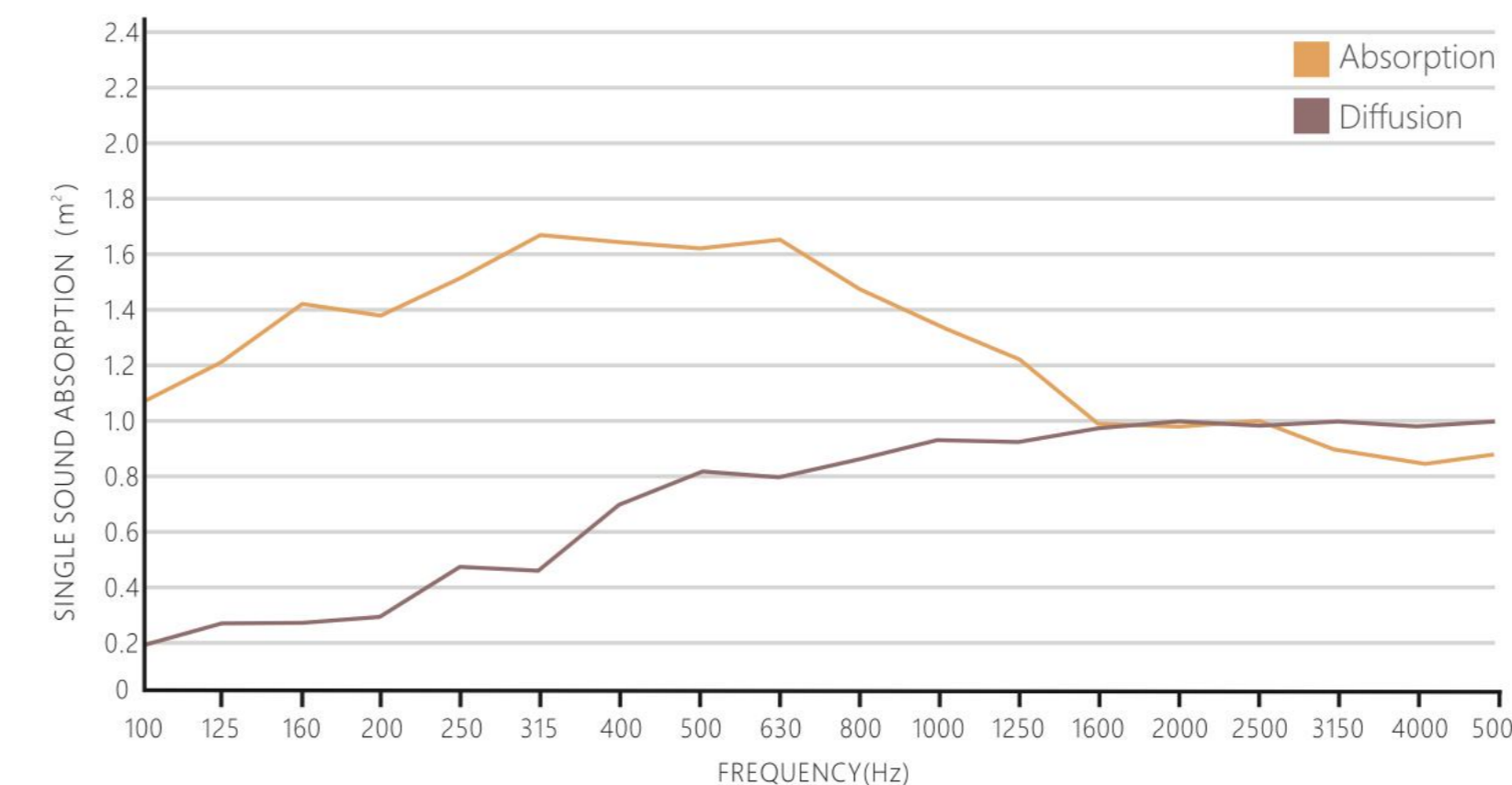
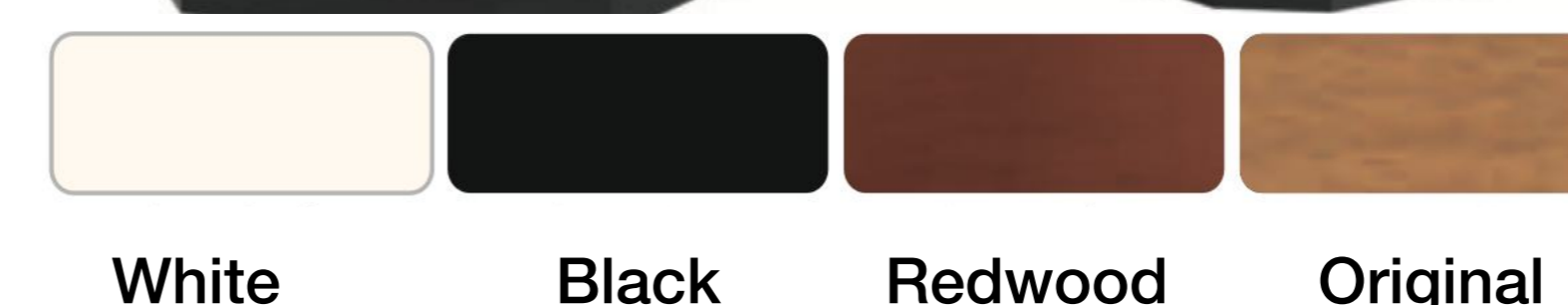

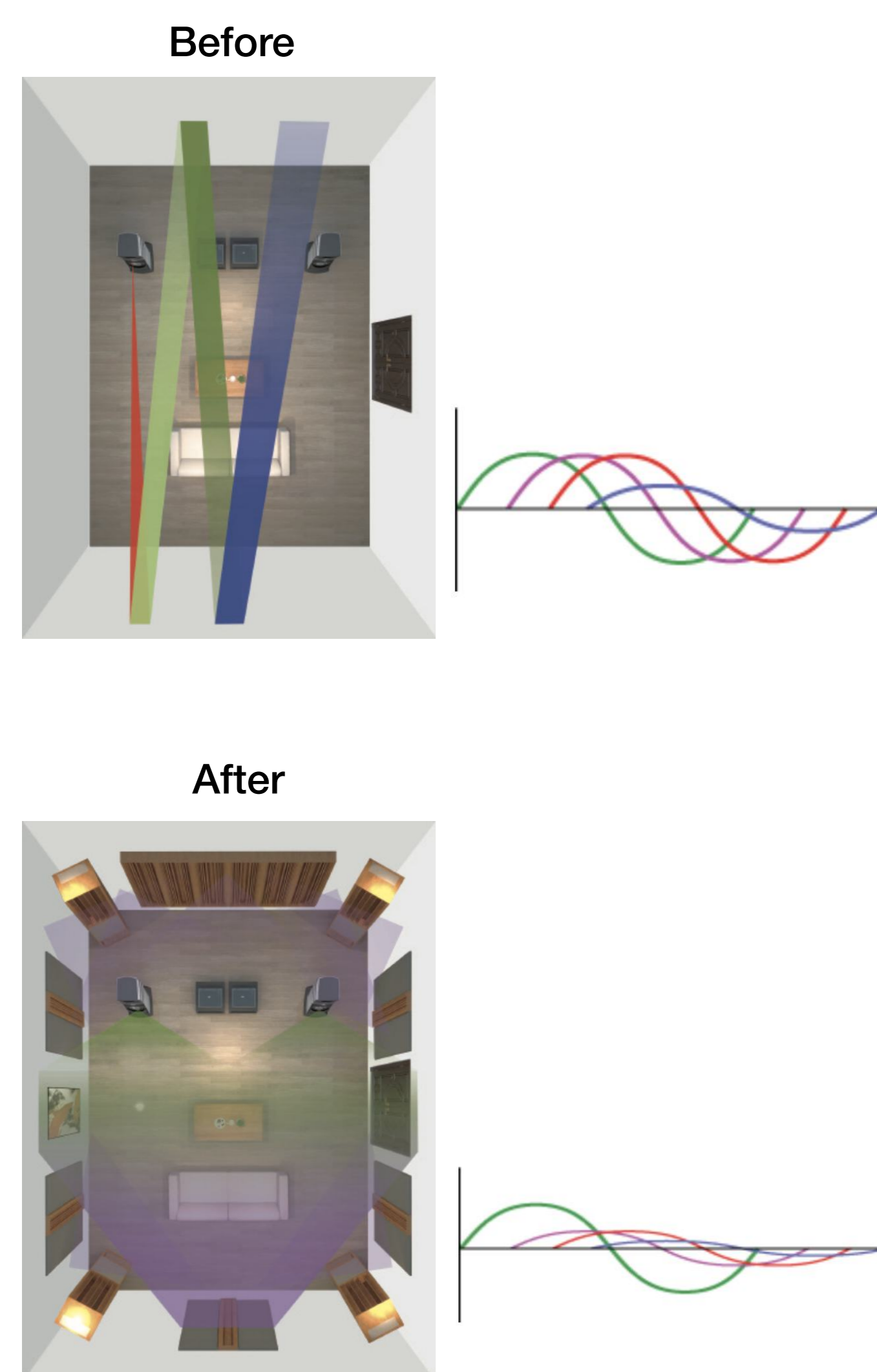
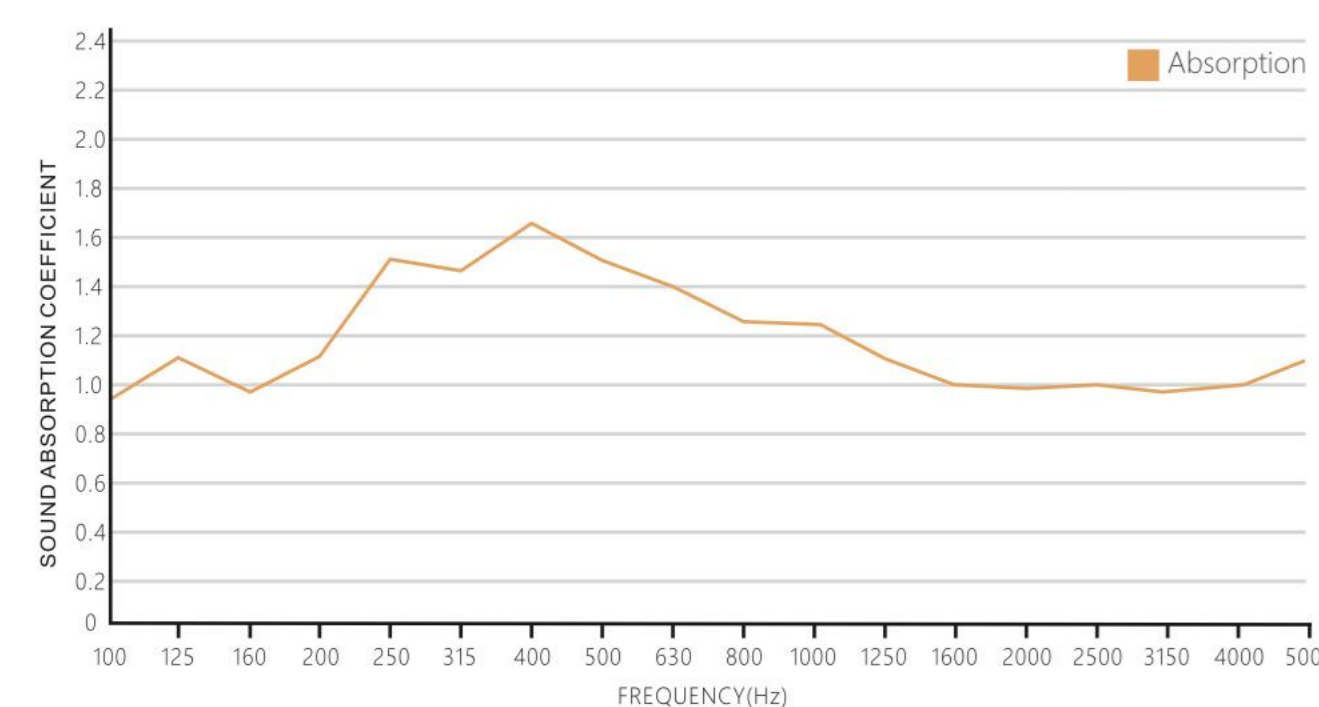
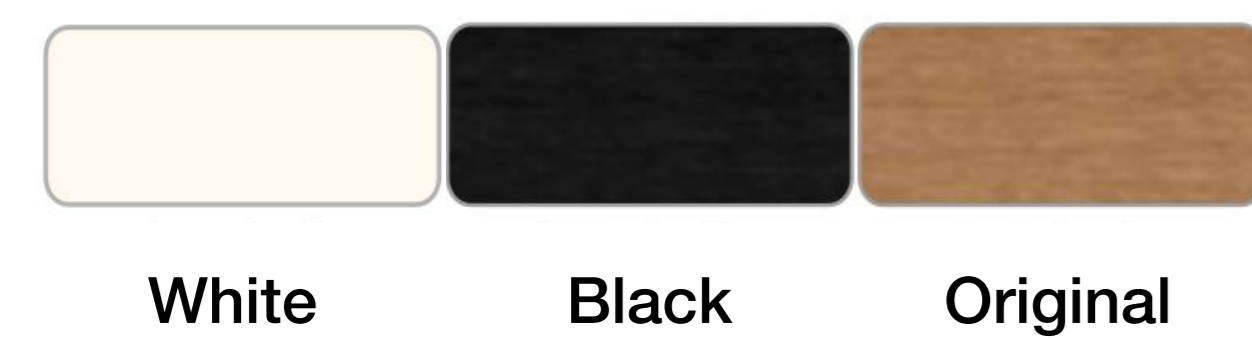
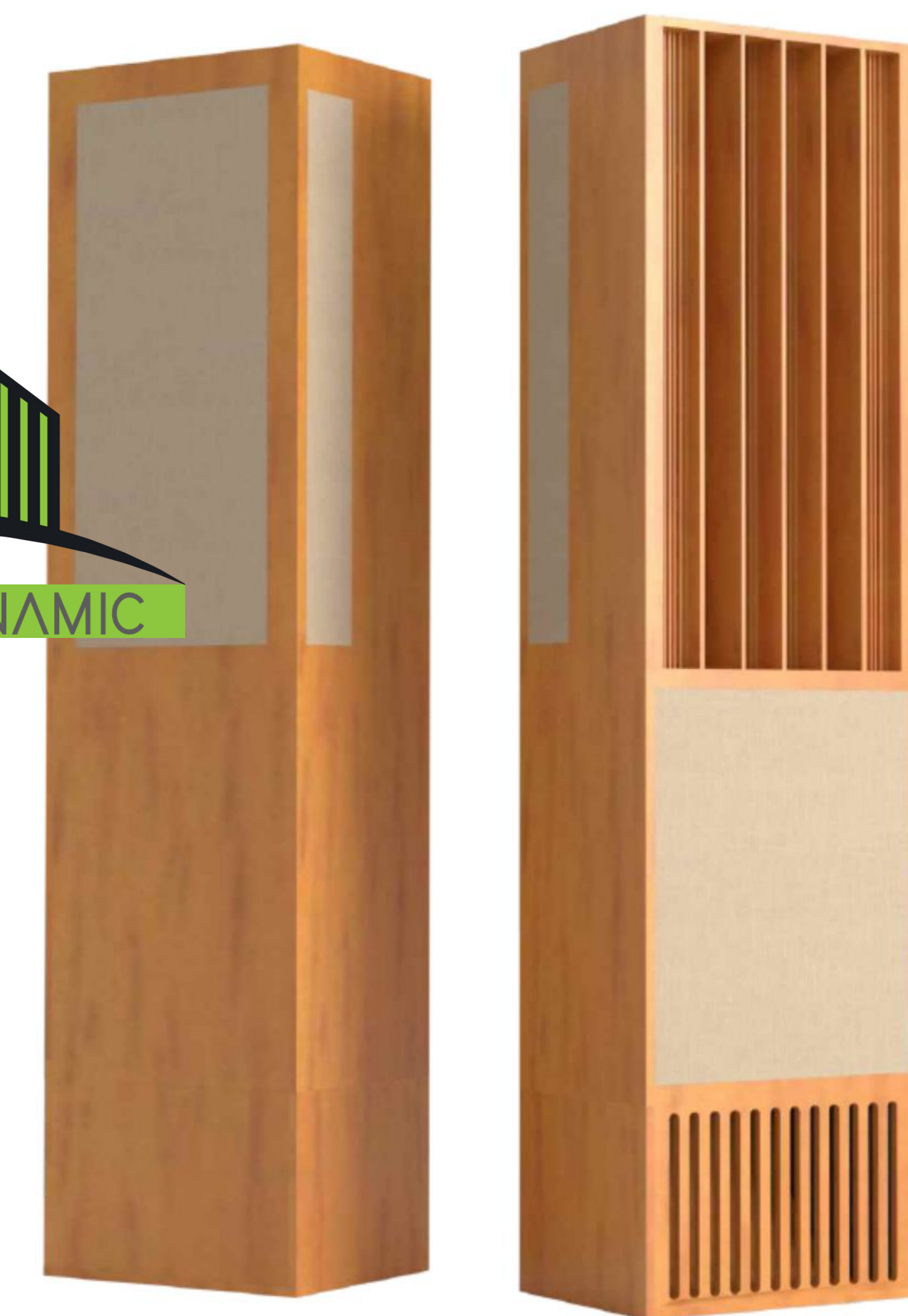
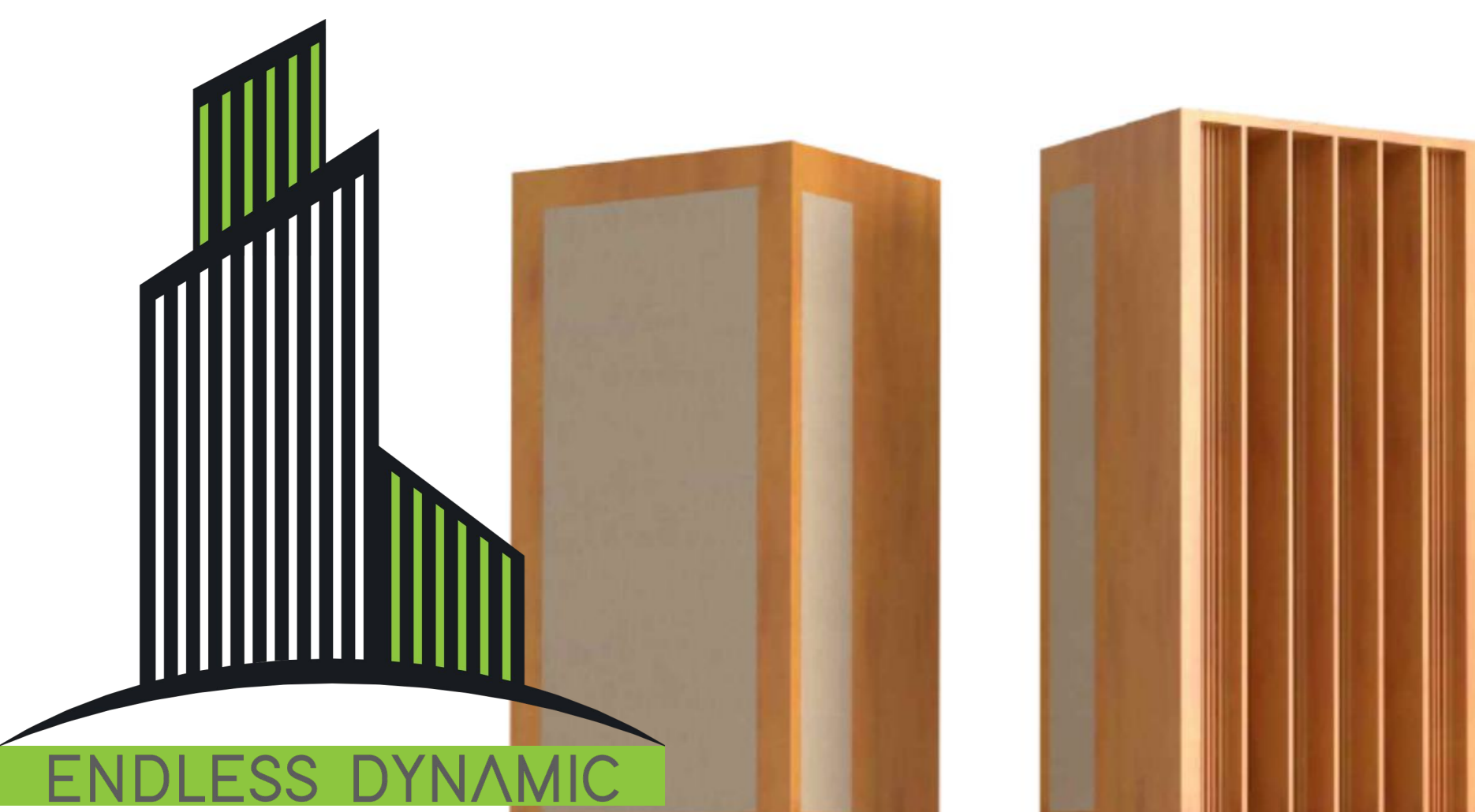

Name: Bach Acoustic Array

Models: AQ1000SW

Structure: The high-density solid wood structure is composed of three structures of medium and high frequency diffusion, medium and low frequency absorption cavities.

Eco-Friendly: E0 standard

Finish: 268-12 Acoustic fabric for sound absorption.

Weight: 100 Kg

Size: H2350 *W600*D450mm

Application: Suits for bigger rooms- listening rooms, studio and home theater.

AQ100SW integrates three sound optimization modes, the upper half of the front composite QRC medium and high frequency diffusion, the built-in Helmholtz resonator in the middle, and the lower labyrinth low frequency trap.

Comb filtering and residual low frequency commonly found in rectangular spaced are a sound quality killer.

Conventional narrow-band diffusers and low-frequency traps are difficult to control.

Bach's innovative acoustic array design and composite QRD diffusion break through everyone's concerns about QRD diffusion bandwidth, the built-in Helmholtz resonator captures the mid-low frequency margin in the most efficient way.

The most unexpected thing is that its low-end labyrinth-type low-frequency trap phase guide, runs through the back of the entire combination, and the 2.4 meter-long phase guide is realized and reduces the consumption of ultra-low-frequency headroom waves below 50Hz.

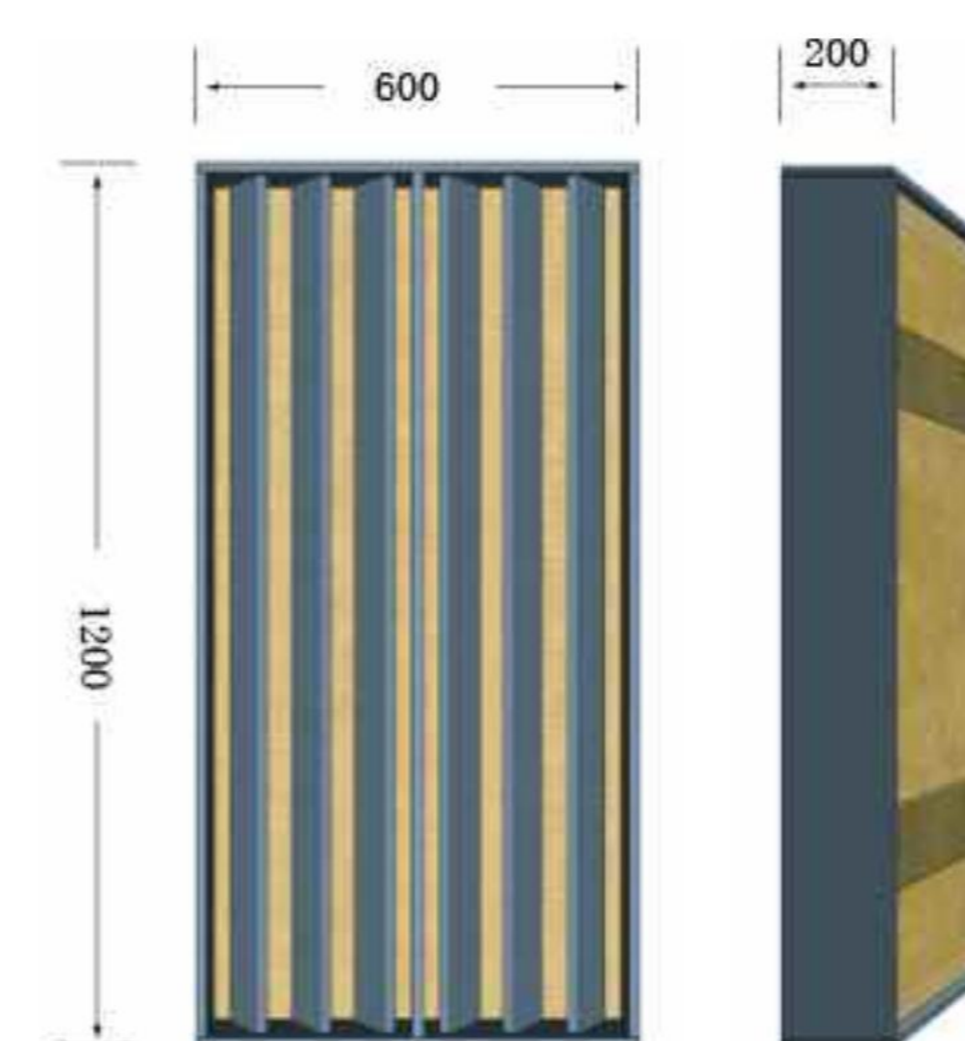
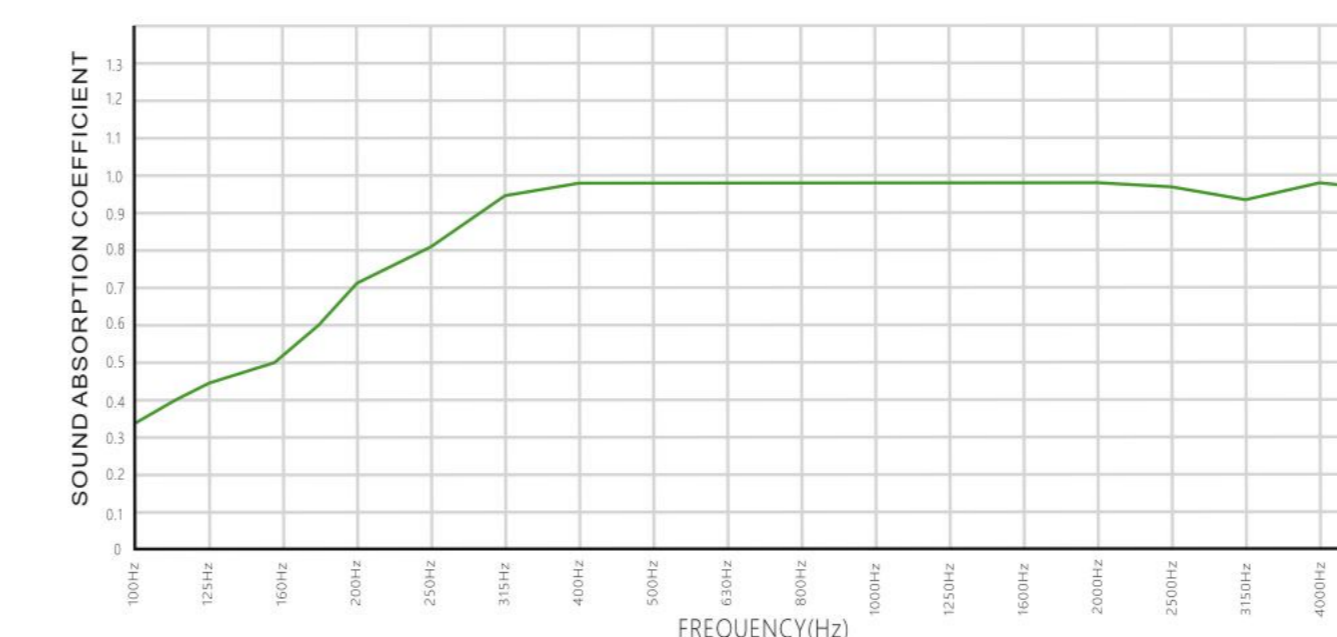
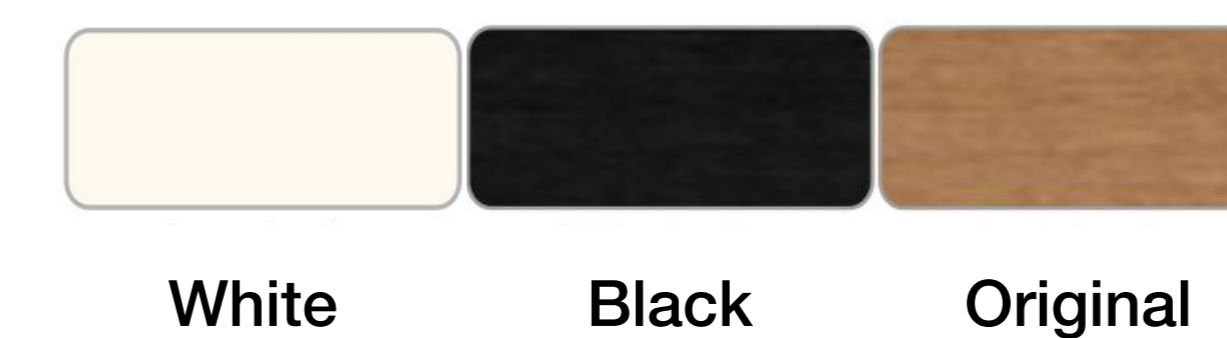
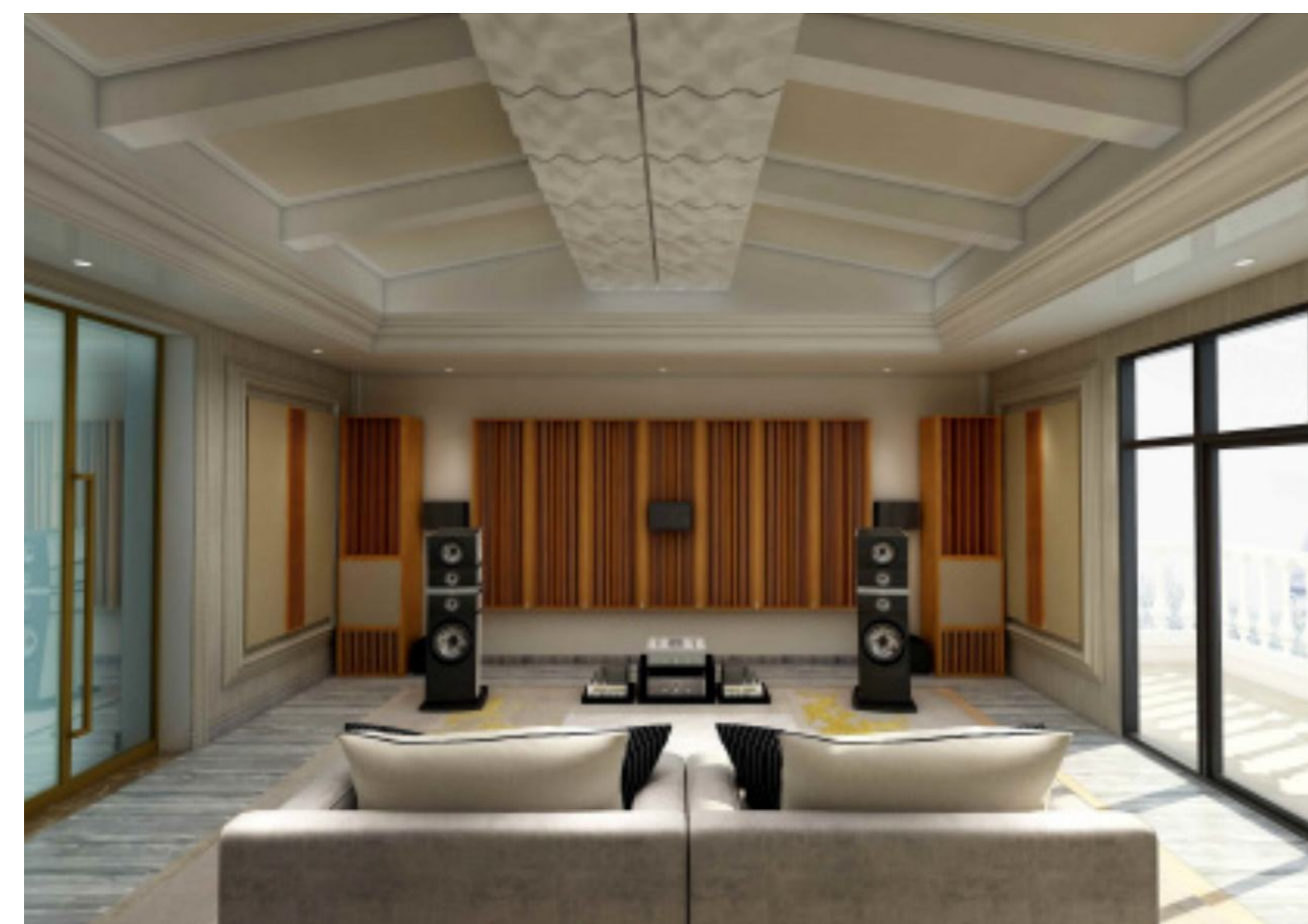

Name: Smartfuser

Models: AQ1000M

Weight: ~ 16.2 Kg/pcs

Size: H1200 *W600*D200mm

Variable lath diffusion and cavity absorption design to effectively eliminate flutter echos and standing waves. Diffusion angles can be adjusted as required by different applications e.g recording rooms, home theater etc. The controllable diffuse reflection combination diffuse and absorb to eliminate high frequency flutter echoes and effectively make use of the main reflected sound. It has an overall size of 600x1200mm, composed of 6 variable direction diffusion laths, which rotate to different angles to eliminate high frequencies and create the required energy distribution. High density strong sound absorbing board is provided behind the reflection laths to effectively absorb 250Hz and eliminate the harmonic waves behind the oriented reflection board.

To summarise these units will absorb negative reflections, standing waves and troublesome flutter echos to tune the near wall main reflection for HIFI listening rooms, home theaters and small audio studios.

The elegant appearance with porous meshes and resin hardened edges makes it suitable for most architectural space designs.

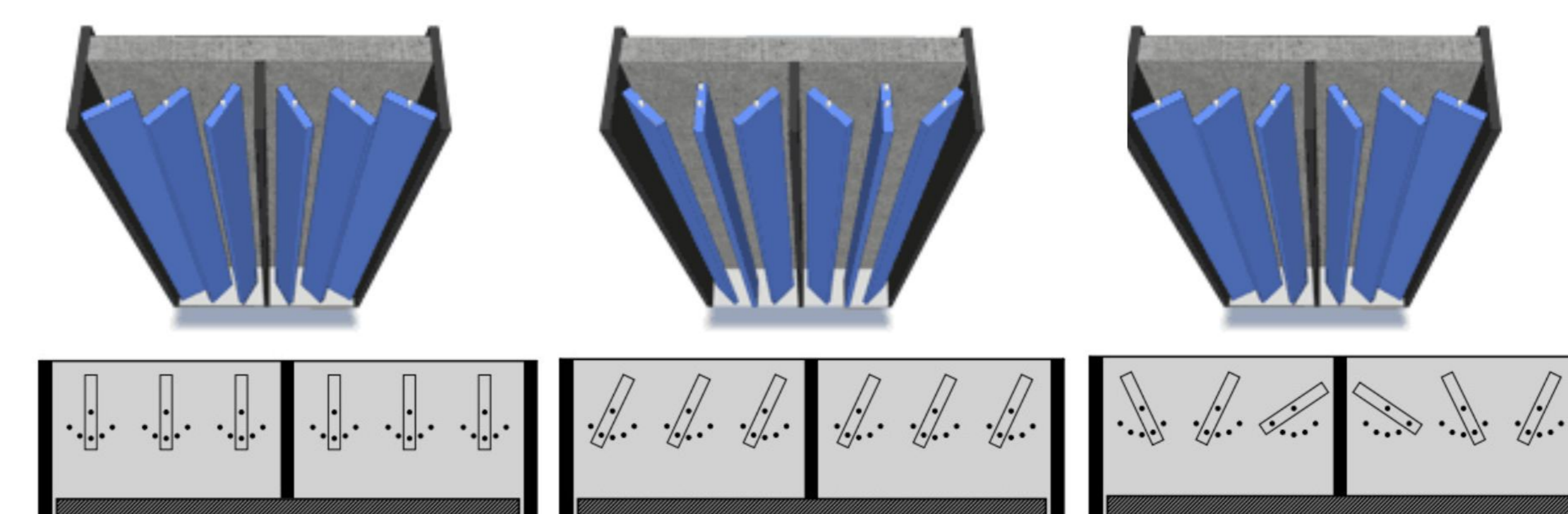

Vertical opening for sound absorption Inclined opening for sound reflection Left opening for diffusion

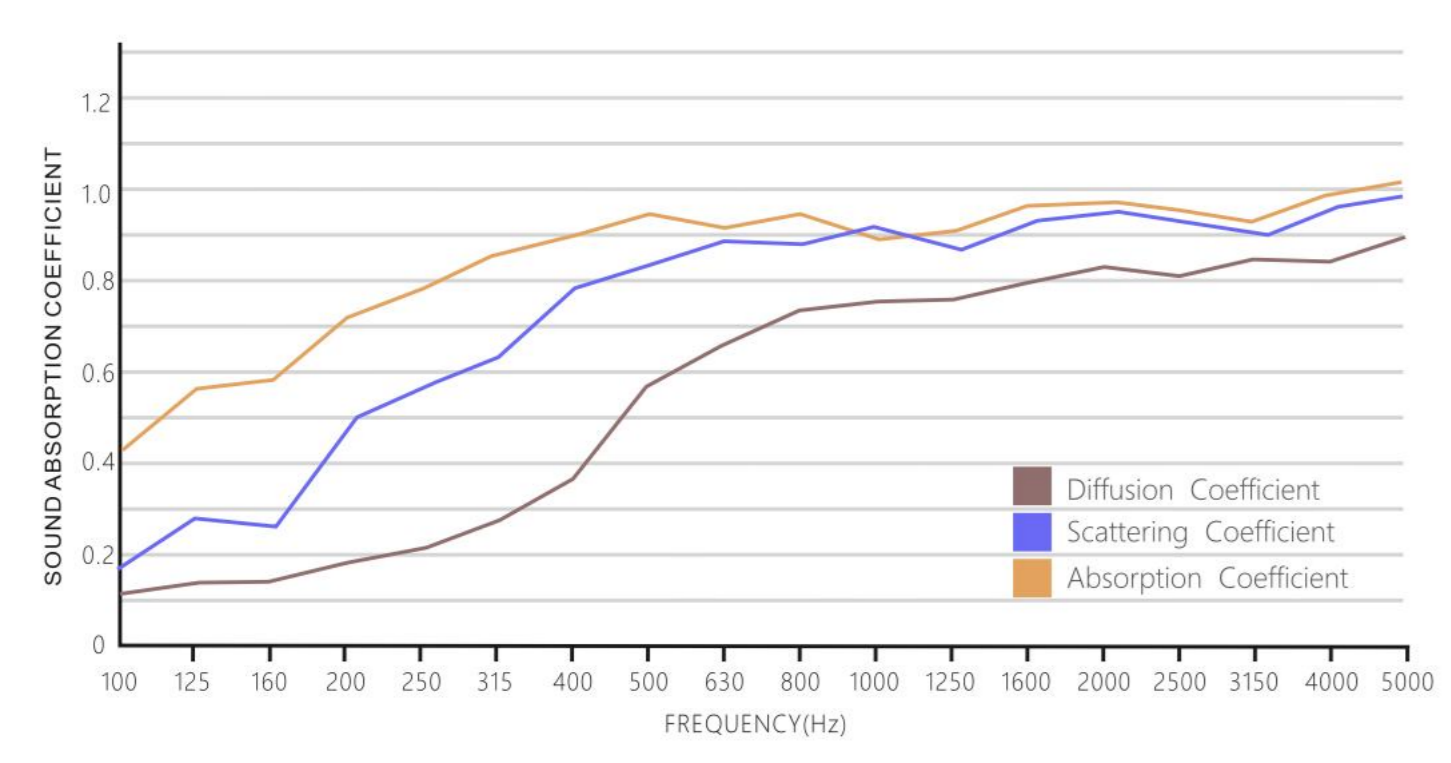

Name: Movable Acoustic Baffle

Models: AQ1000H/HD

Structure Properties: A patented anti oxidation treated metal frame that is anti sound reflection & resonance.

Side A performs excellently in absorbing sound in all frequency.

Side B - The MLS diffusing cloud is made by HIPS forming process

Base materials: Ultra-micropore glass fiber in different density. Green treatment without any formaldehyde emission.

Eco-Friendly: E0 standard

Finish: 1 - Acoustical fabric for sound absorption.
2 - Diffusion side: PU Matte painting.

Flame retardation: Base material - Grade A

Weight: AQ1000H 28 Kg / AQ1000HD 15.5 Kg

Size: AQ1000H H2100*W800*D200mm / AQ1000HD H2000*W800*D100mm

Scope of Application:
AQ1000H - A semi-enclosed acoustic absorbing shell for portable stage.
AQ1000HD - A hanging acoustic absorbing shell.

Movable acoustic baffle help to control long reverberation time, fluttering echo, parallel sound reflection and standing wave in medium frequency for House of prayer, halls, multi-functional rooms and indoor studios but also outdoor acoustic shell solution.

Installation:

1AQ1000h - Standard fixing system with wheels; Hidden rectangle fixed groove

AQ1000HD - Standard holes for horizontal or vertical hanging.

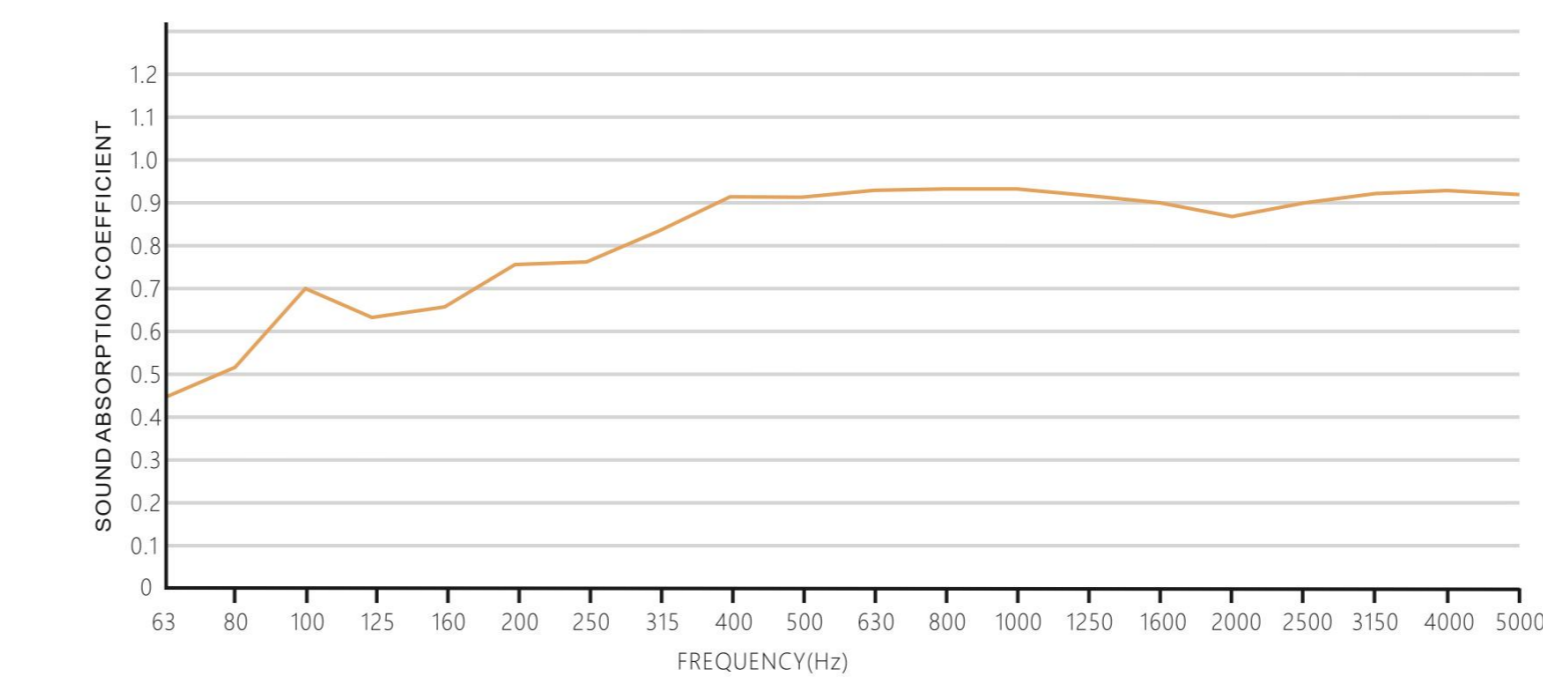
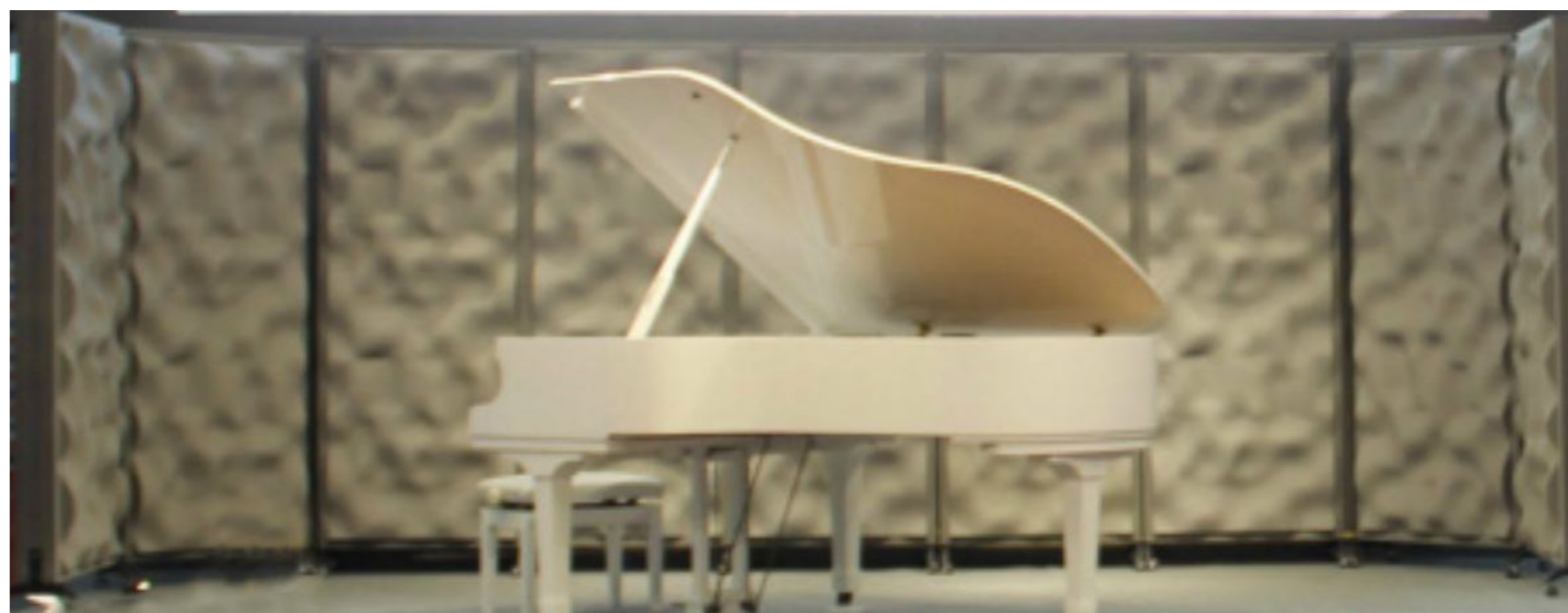

Name: Movable Acoustic Baffle

Models: AQ150W

Structure Properties: A patented anti oxidation treated metal frame. AB full frequency strong sound absorption on both sides.

Base materials: Ultra-micropore composite acoustic wool in different density. Zero-emission.

Eco-Friendly: E0 standard

Finish: Flocking flame retardant acoustic cloth.

Flame retardation: Base material - Grade A

Weight: 15.6 Kg

Size: H1620*W800*D200mm

Scope of Application: Easily build movable sound absorption barrier.

The movable acoustic baffle can easily and effectively control the reverberation time, vibration echo, parallel plane reflection sound, medium and low frequency standing wave and other environmental sound defects in conference rooms, multi-function halls, offices and other spaces.

The two-sided absorbing design ensures very good sound absorption performance, and the ultra-micropore composite acoustic wool of different density and fabric finish enhances the absorbing coefficient.

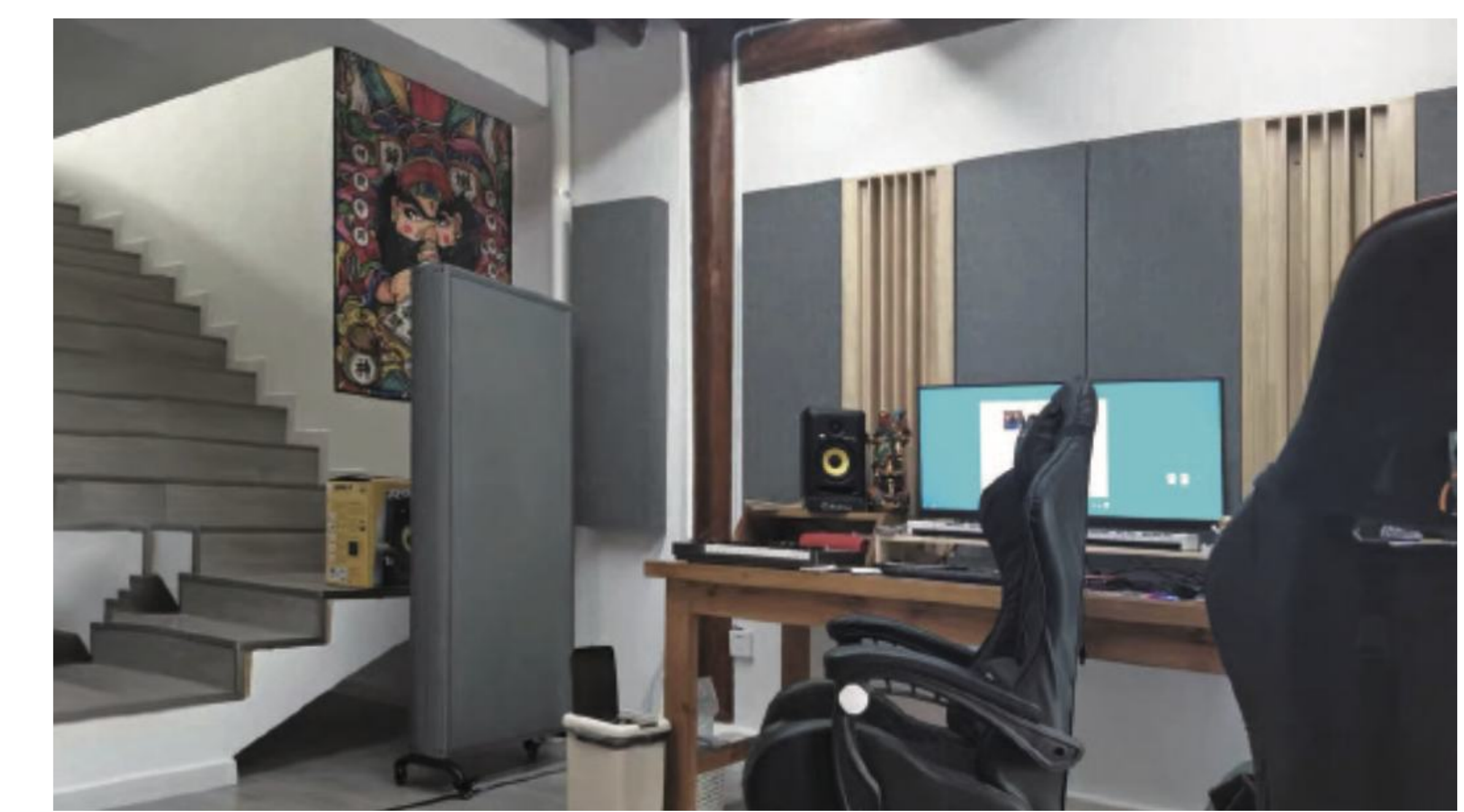



Name: Chessfuser

Models: D64

Base material: Rubber solid wood

Eco-Friendly: Purely natural raw wood, PU finish paint, E0 standard

Diffusion frequency range: 430Hz-861Hz(max 2730Hz)

Weight: 11.6 Kg

Size: H600 *W600*D100mm

Scope of Application: Opera houses, music halls, places of leisure, privet theaters, recording studios, HIFI listening rooms etc.

With high end indoor sound quality requirements for building acoustic decoration.

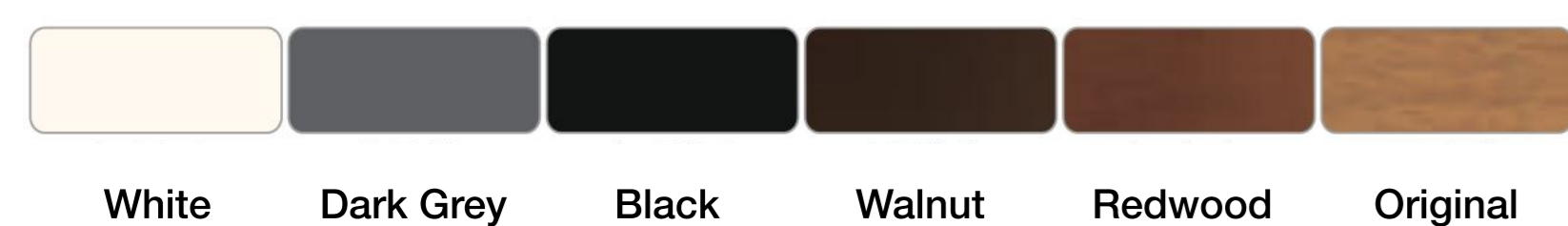

D64 solid wood diffuser is a located sequence grating based on QRD theoretic formula calculations. Its groove depth and width enable it to have uniform diffuse reflections for the incident sound from different angles and all the directions to make human voices more agreeable and high frequencies more gorgeous like in a large hall.

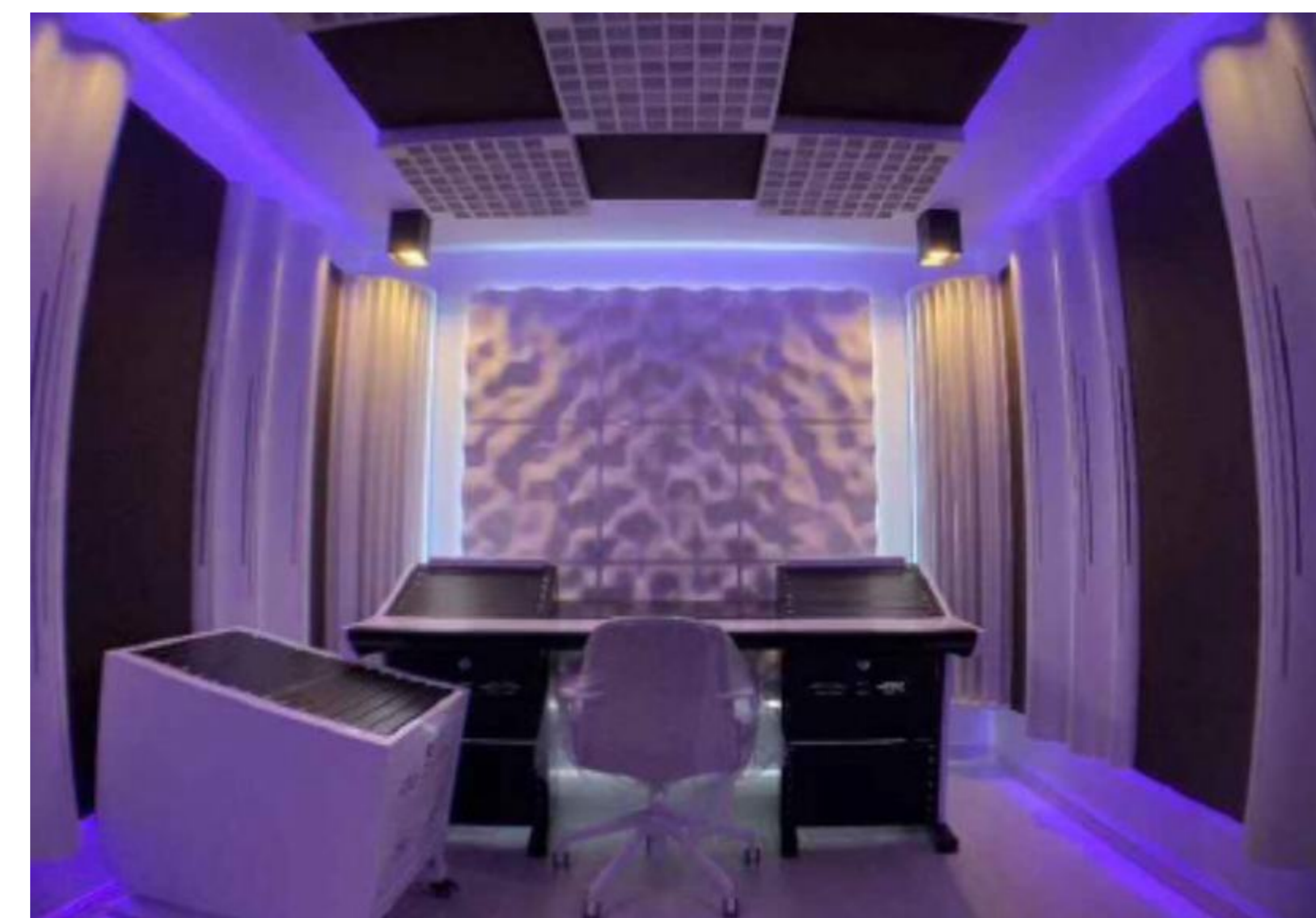
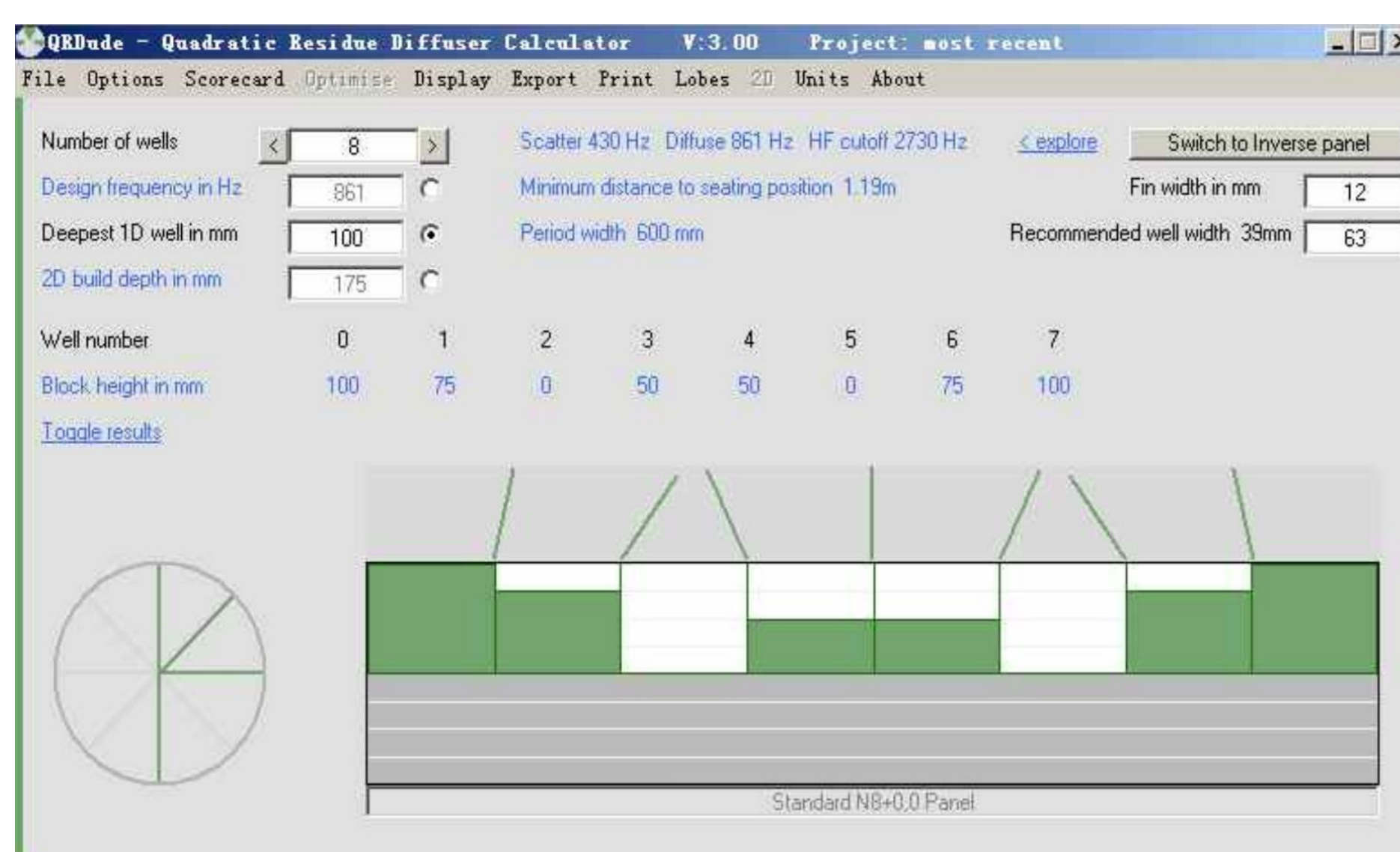
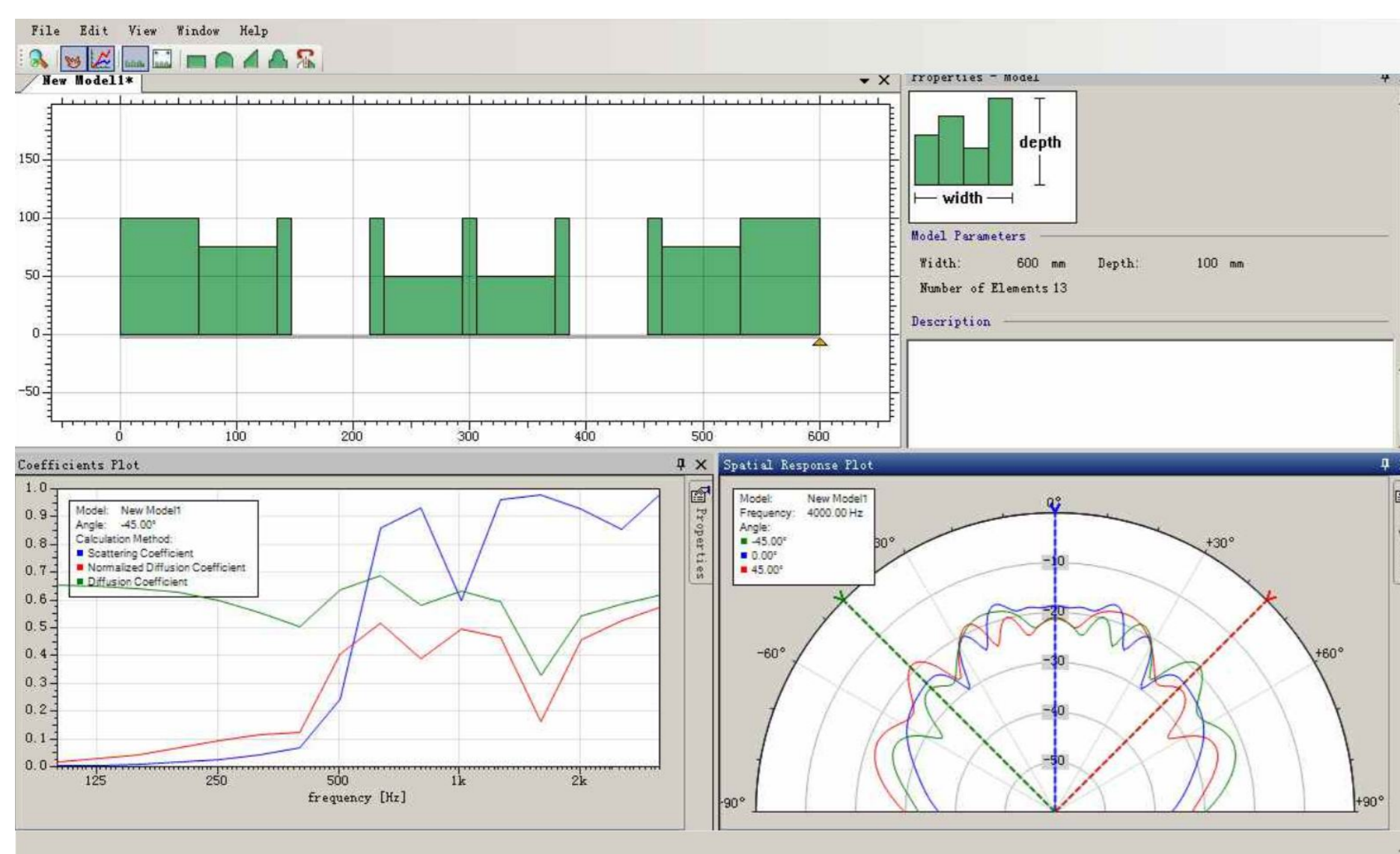

Name: Quadrifuser

Models: D30S / D30

Base material: Rubber solid wood

Eco-Friendly: Purely natural raw wood, PU finish paint, E0 standard

Diffusion frequency range: 571Hz-1142Hz(max 5548Hz)

Weight: D30S ~11.8 Kg D30 ~ 23.6/35.4 Kg

Size: H600 *W600*D100mm

Scope of Application: Opera houses, music halls, places of leisure, privet theaters, recording studios, HIFI listening rooms etc.

With high end indoor sound quality requirements for building acoustic decoration.

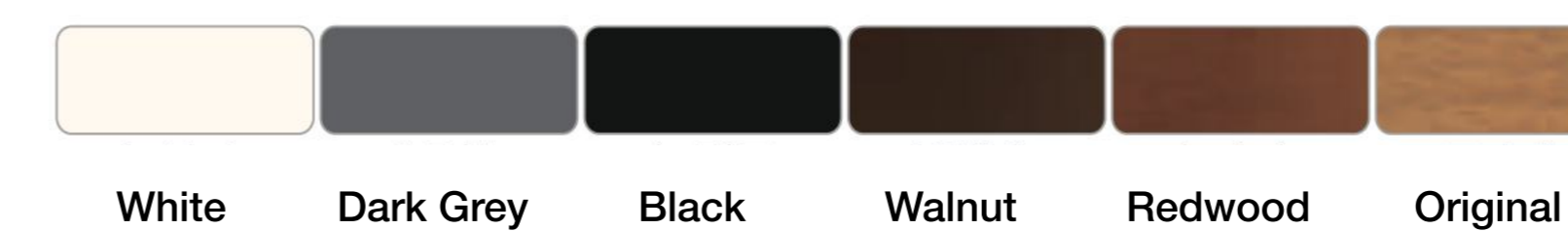

D30 solid wood diffuser can be used to diffuse the sound energy in a stereophonic manner, prevent echos and standing waves to realize diffusion in all directions, and improve the articulation of sound and sense of space.

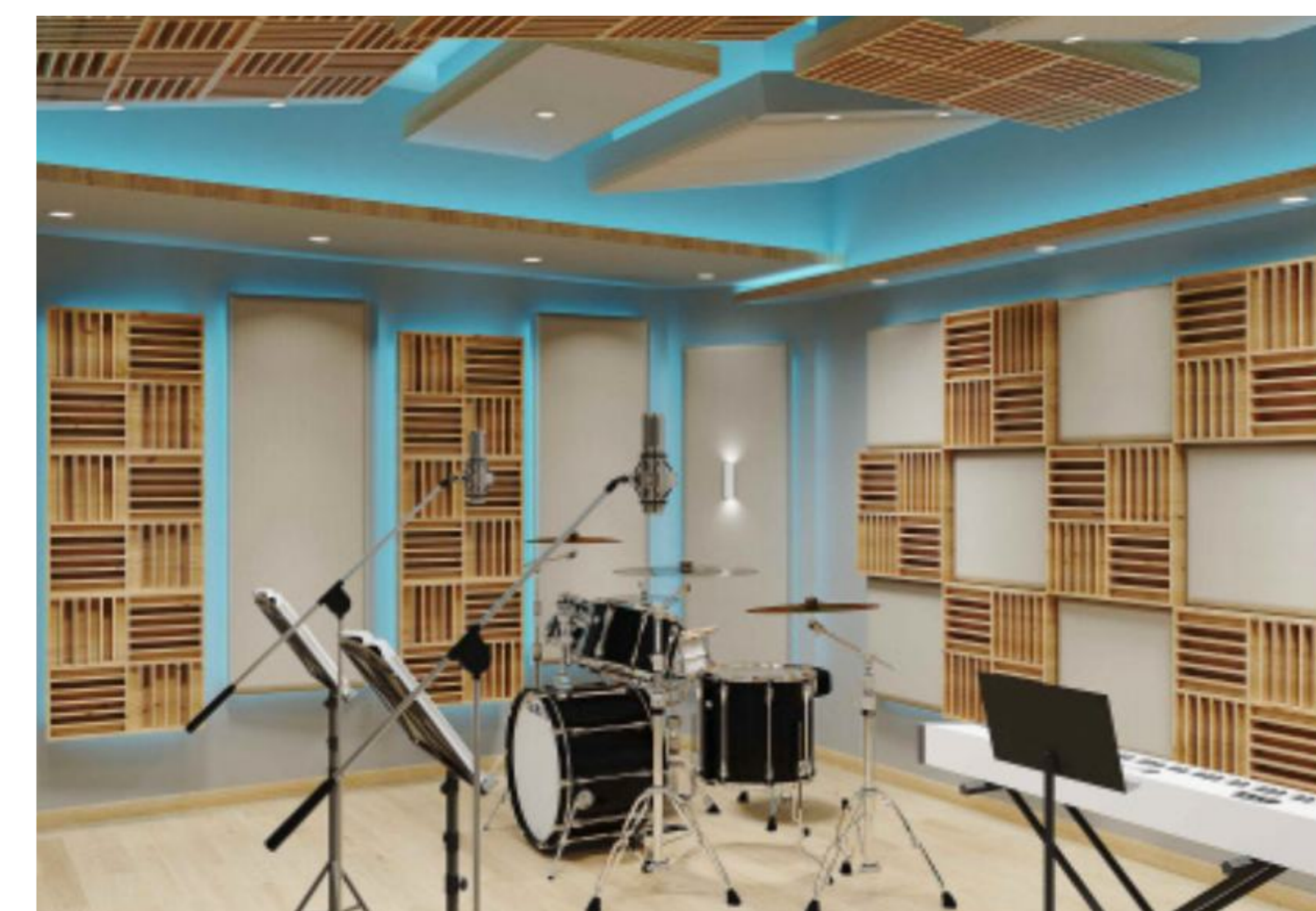
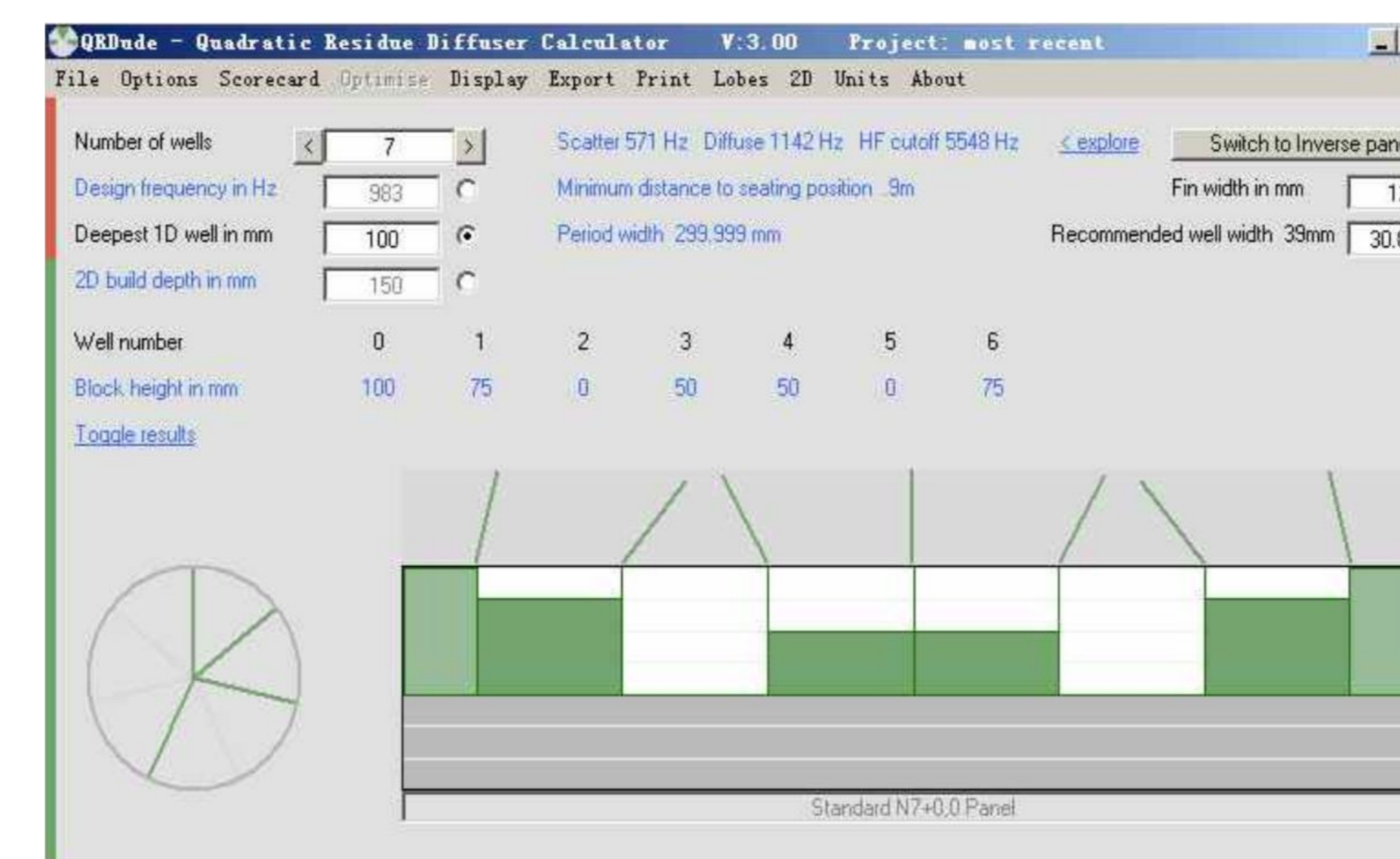
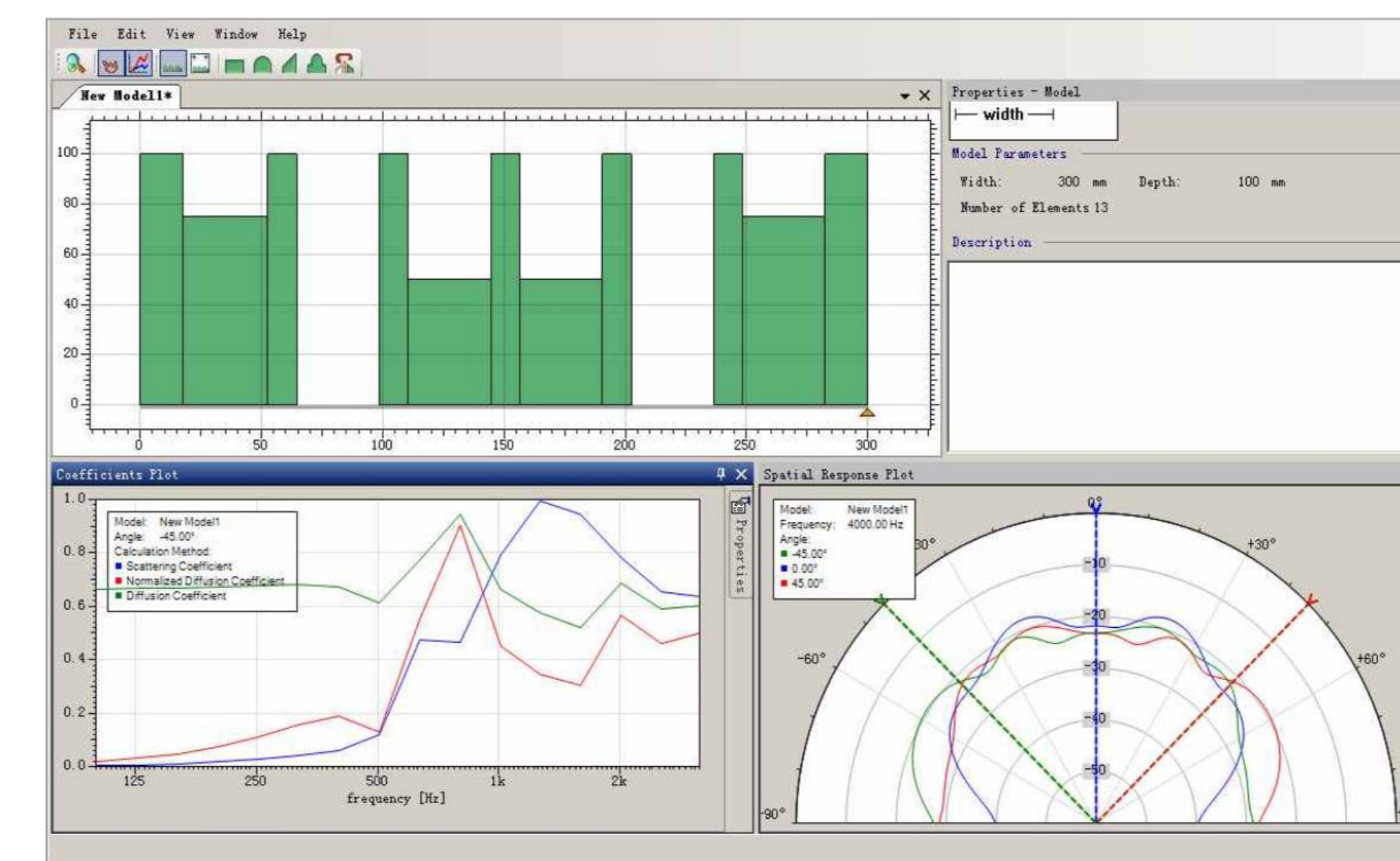



Name: Octofuser

Models: N8

Base material: Rubber oak wood

Eco-Friendly: Purely natural raw wood, PU finish paint, E0 standard

Diffusion frequency range: 491Hz-983Hz(max 2324Hz)

Weight: 11.5 Kg

Size: H600 *W600*D100mm

Scope of Application: Opera houses, music halls, places of leisure, privet theaters, recording studios, HIFI listening rooms etc.

With high end indoor sound quality requirements for building acoustic decoration.

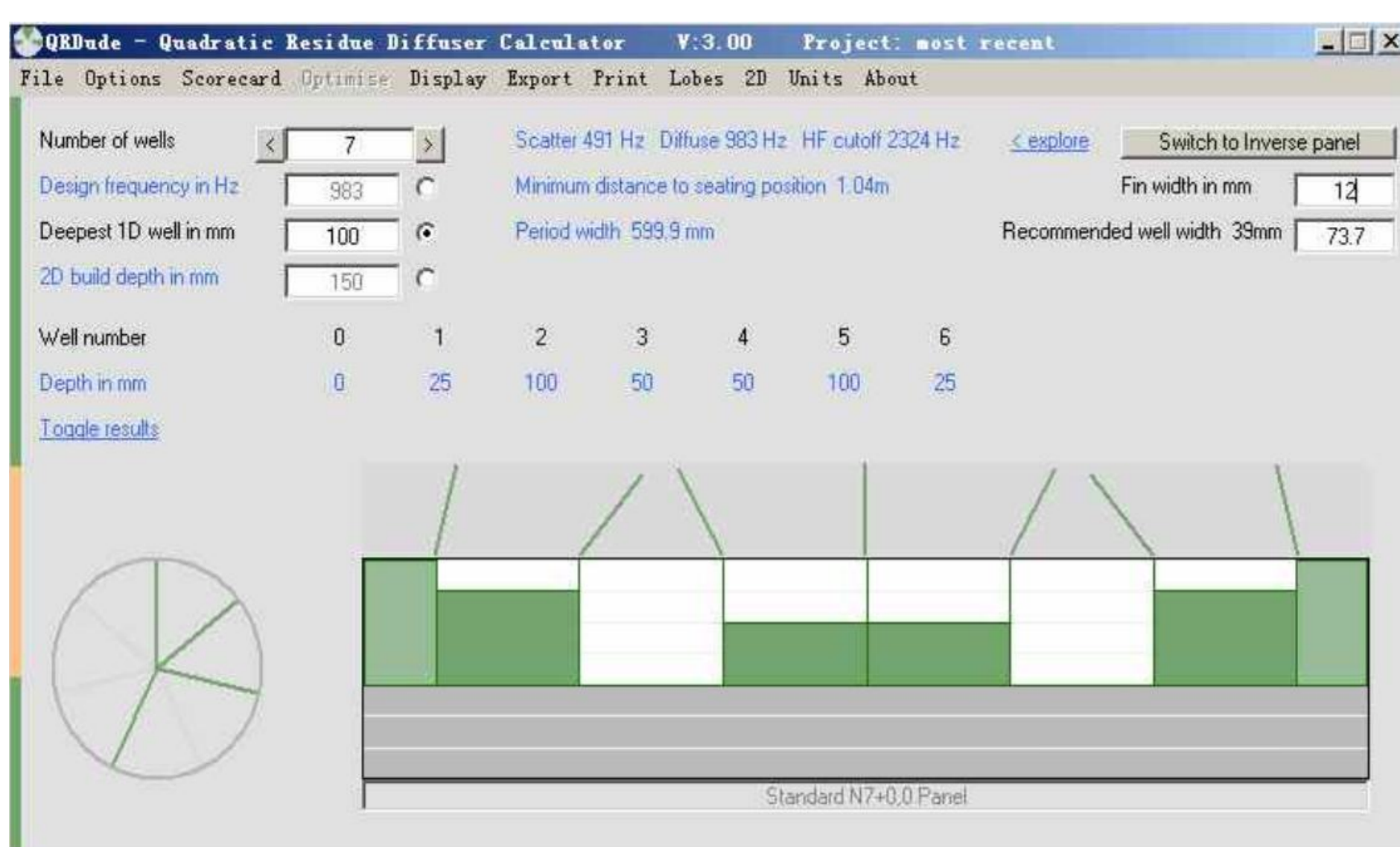
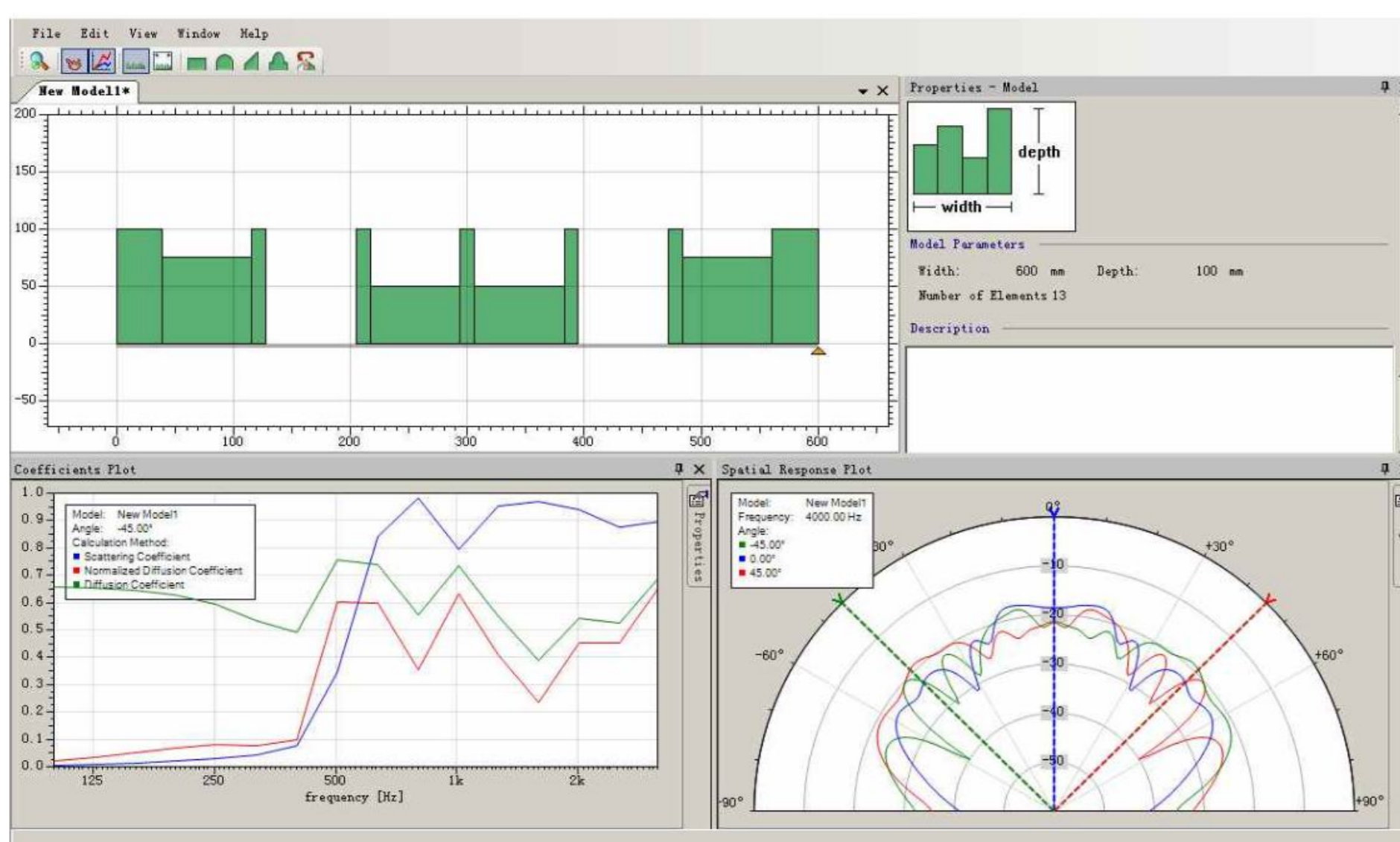

N8 solid wood diffuser can be used to diffuse the sound energy, prevent echos and standing waves to realize diffusion in all direction and improve the articulation of sound



Name: Metafuser

Models: N29

Base material: Rubber oak wood

Eco-Friendly: Purely natural raw wood, PU finish paint, E0 standard

Diffusion frequency range: 524Hz-1049Hz(max 9555Hz)

Weight: H1200~41.5Kg / H1500~51.8Kg / H1800~62.2Kg

Size: H1200/1500/1800 *W540*D158mm

Scope of Application: Opera houses, music halls, places of leisure, privet theaters, recording studios, HIFI listening rooms etc.

With high end indoor sound quality requirements for building acoustic decoration.

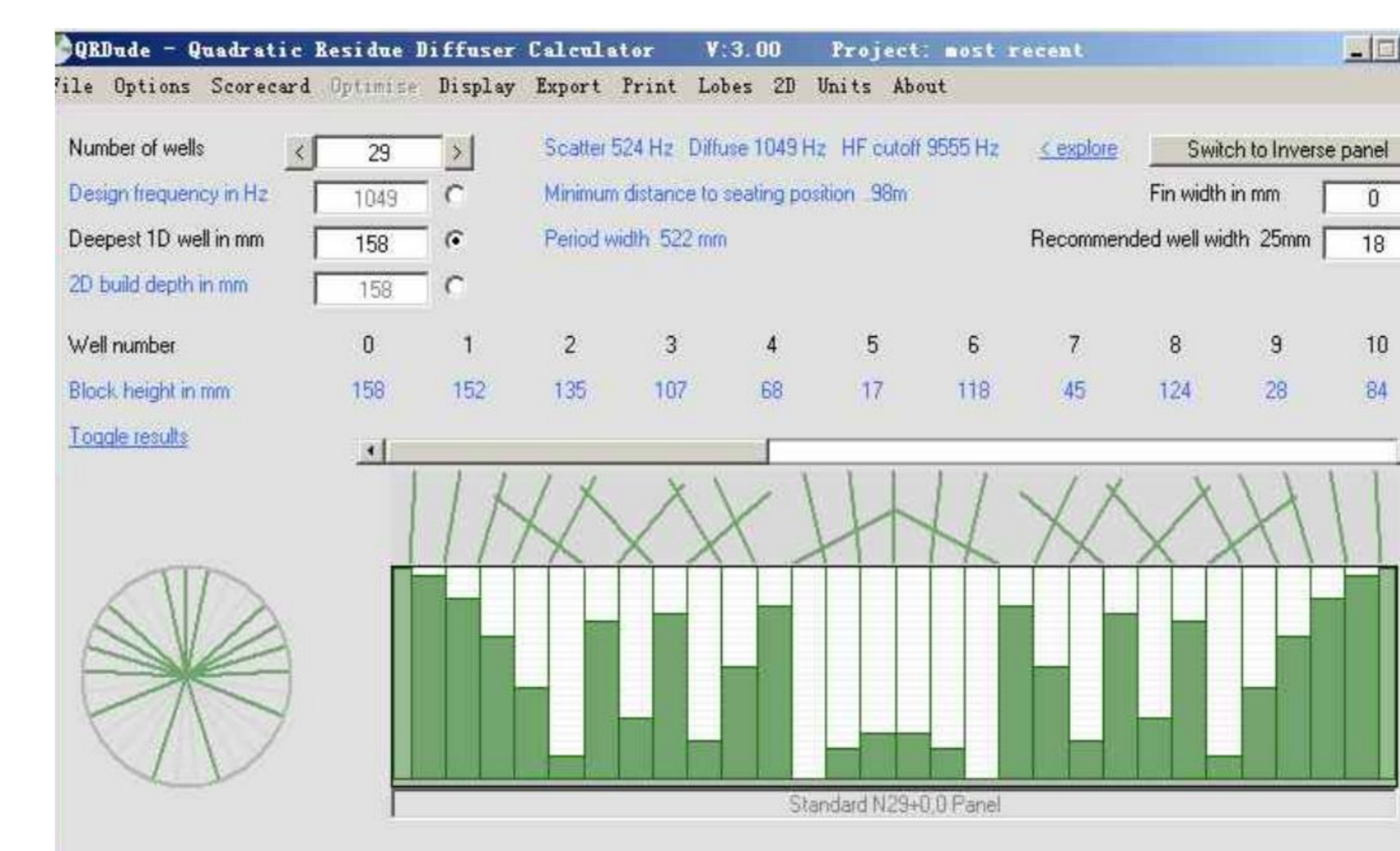
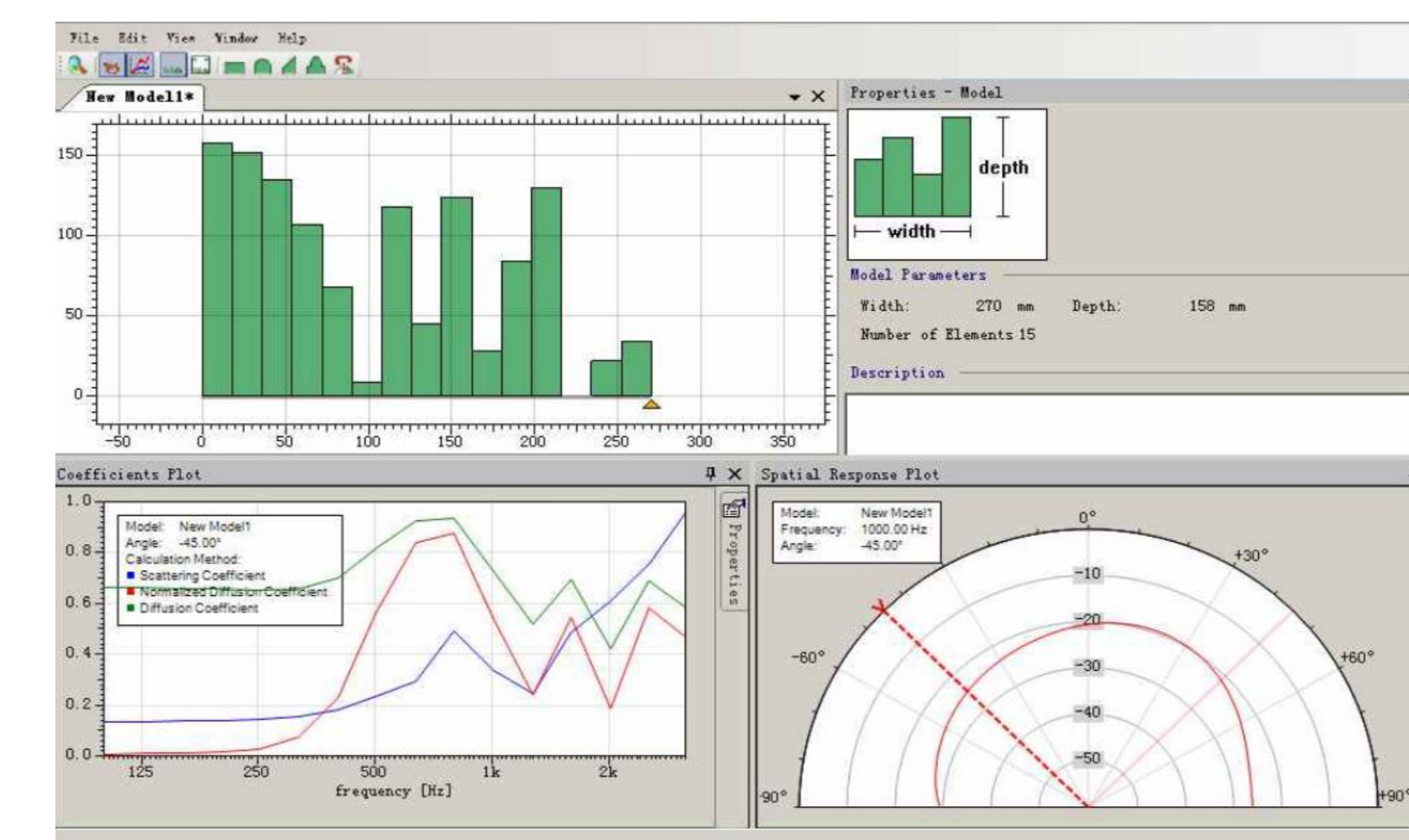
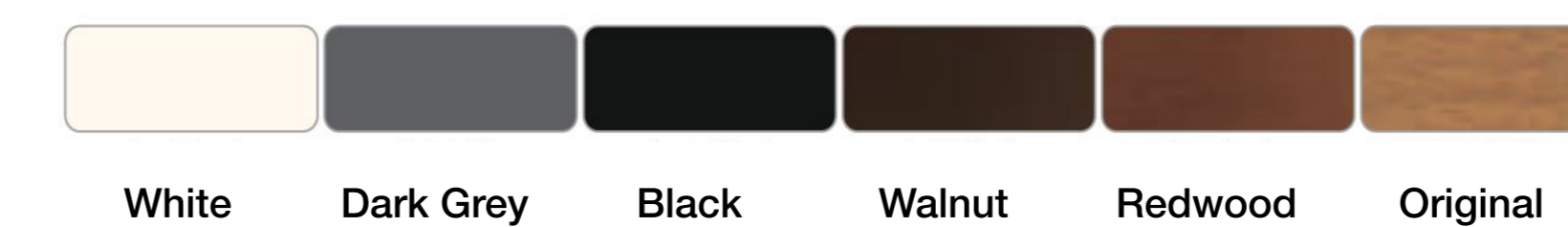

N29 solid wood diffuser can be used to resume the sense of space of sound and improve the sound quality greatly. Its acoustic characteristics reach the requirements of national standards for materials of the same type. It is used along with solid wood sound absorbing boards with slotted holes to effectively improve the fullness, articulation and sense of stereophony of sound.

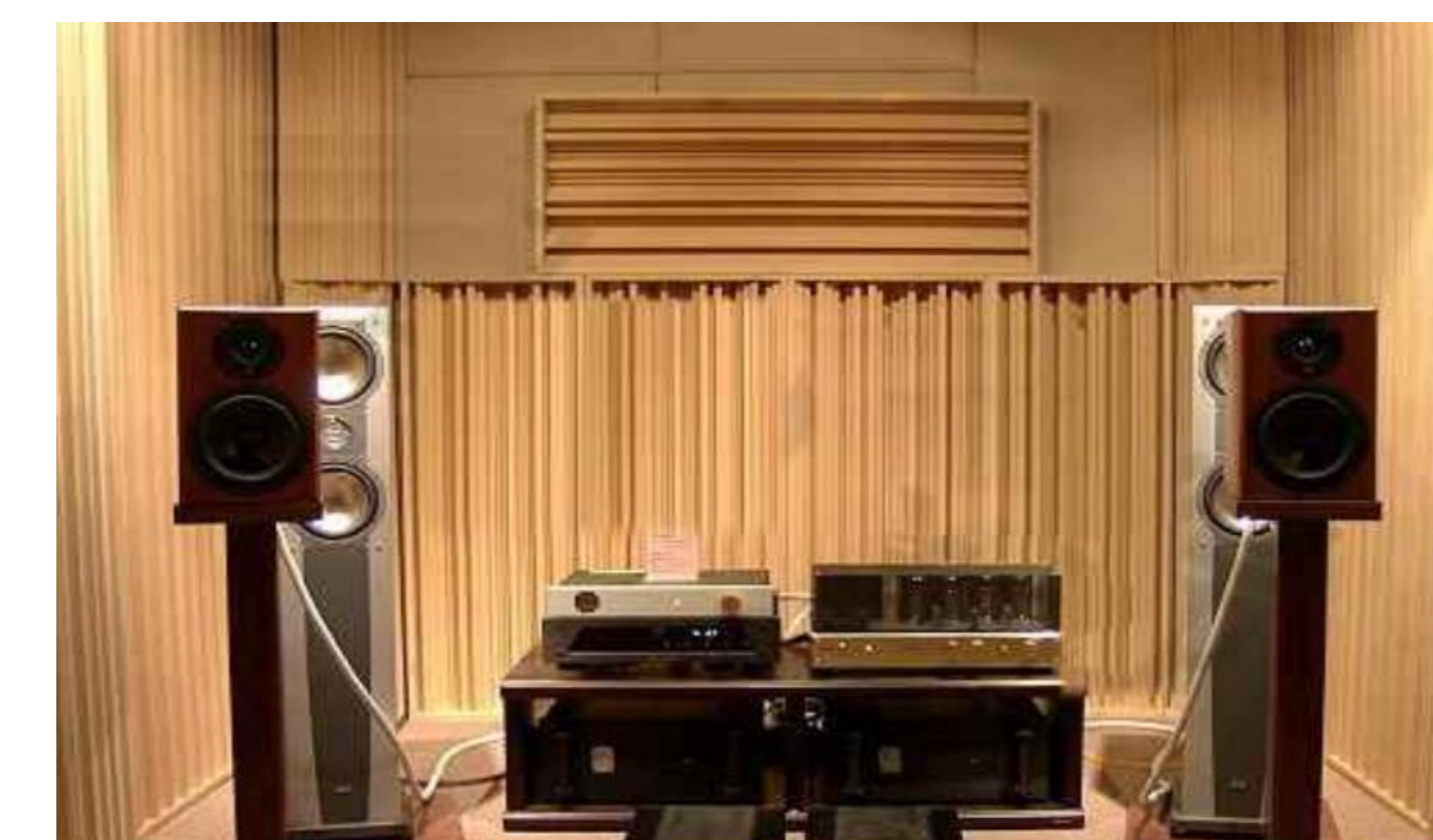
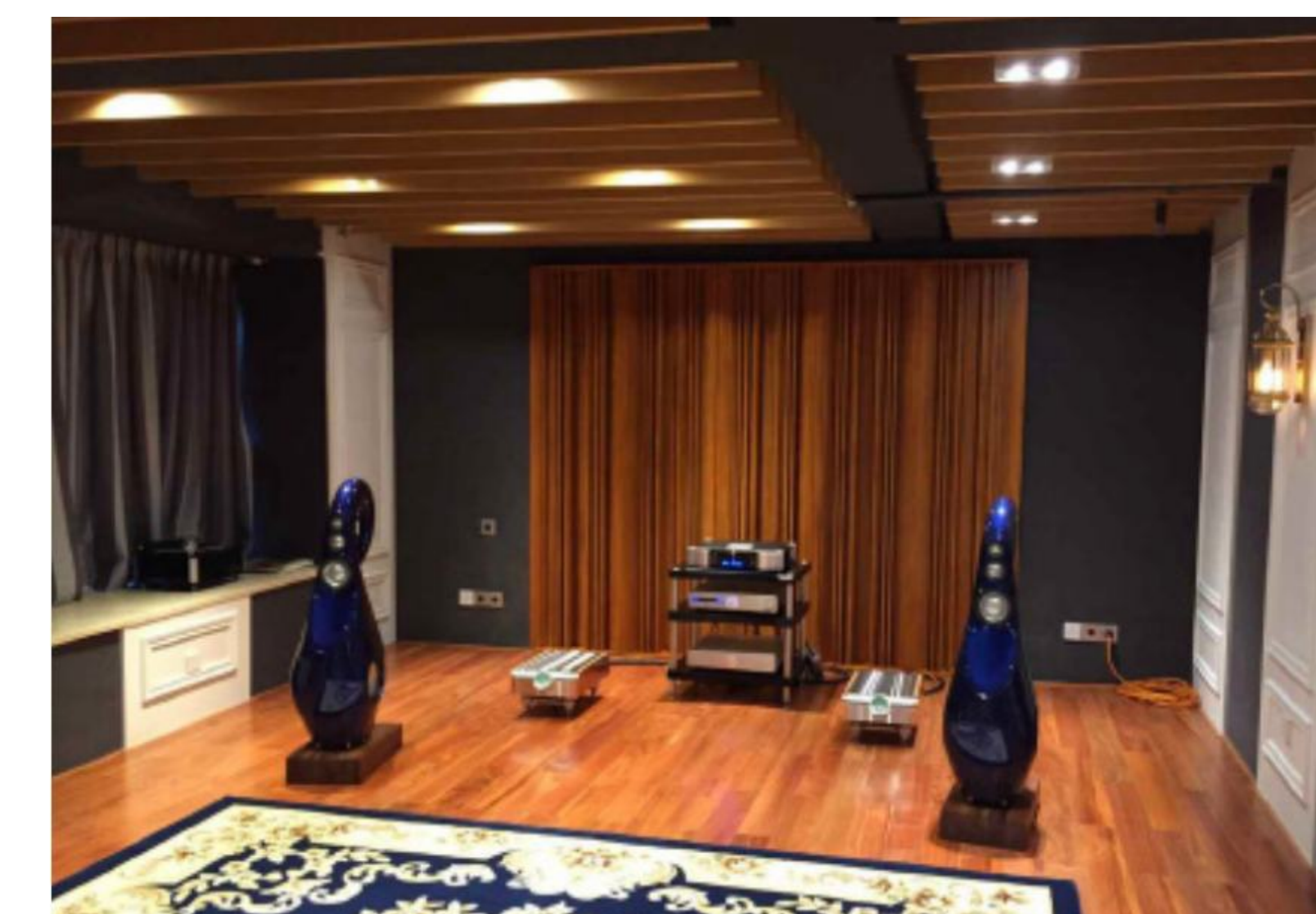



Name: Fuseaser

Models: D80

Base material: Rubber solid wood

Eco-Friendly: Purely natural raw wood, PU finish paint, E0 standard

Weight: H1200~10Kg / H1500~12.6Kg / H1800~15.1Kg

Size: H1200/1500/1800 *W300*D70mm

Scope of Application: Wall mounted. Music halls, home theater, HIFI listening rooms, recording rooms, spaces that require improvement of sound quality and articulation.

D80 has significant diffusion effect. On condition of not increasing the reverberation time, it can deal the fullness, articulation and sense of stereophony.

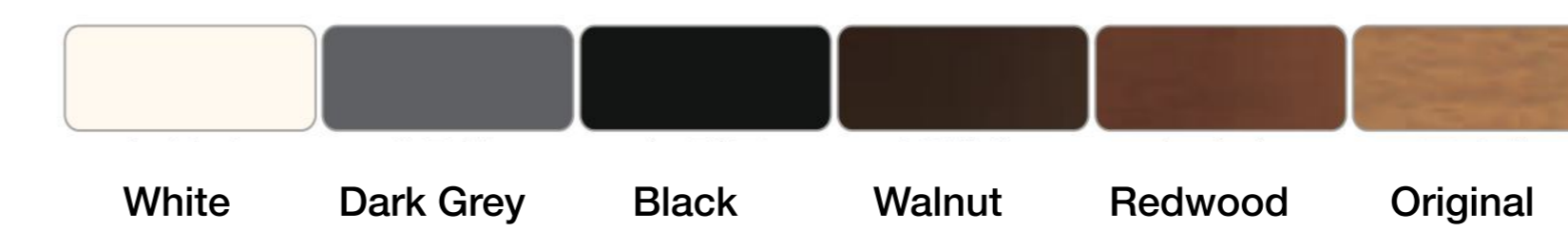
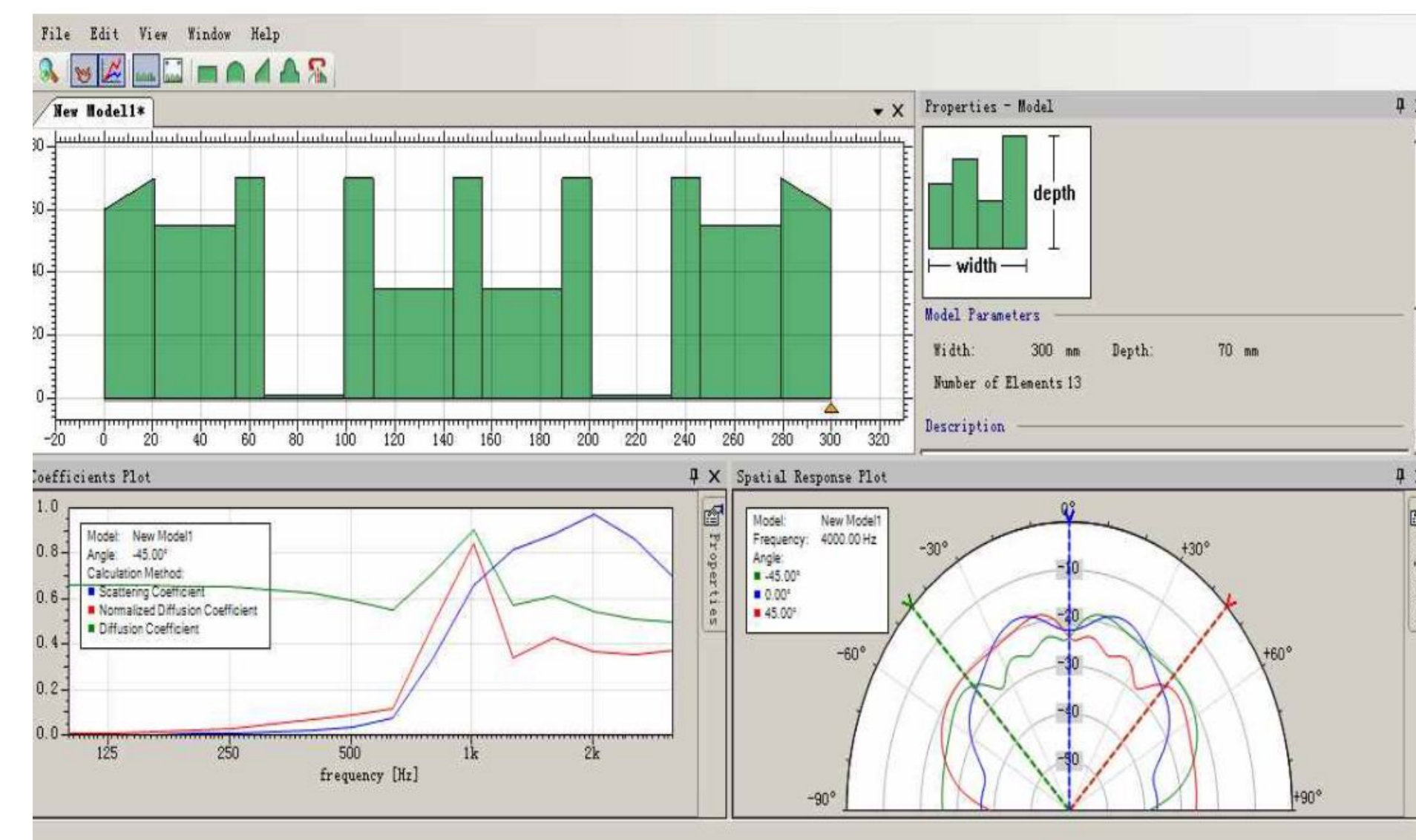

Name: Trapfuser

Models: D80W

Base material: Rubber solid wood

Eco-Friendly: Purely natural raw wood, PU finish paint, E0 standard

Diffusion Principle: When the sound wave is incident on QRD at a horizontal position by 135°, it can reflect the sound out with equal strength by 30°~150°.

Weight: H1200~22.5Kg / H1500~28.1Kg / H1800~31.5Kg

Size: H1200/1500/1800 *W350*D350mm

Scope of Application: Wall mounted. Music halls, home theater, HIFI listening rooms, recording rooms, spaces that require improvement of sound quality and articulation.

D80W is an in-depth solution to the problem of standing waves in corners. As a combination of low frequency absorption and diffusion technologies, it not only solves the problem of sound confusion in corners, but also makes use of the corners to enhance the sound energy by at least 3dB, effectively improving the sound fullness, curve straightness, richness and sense of stereophony.

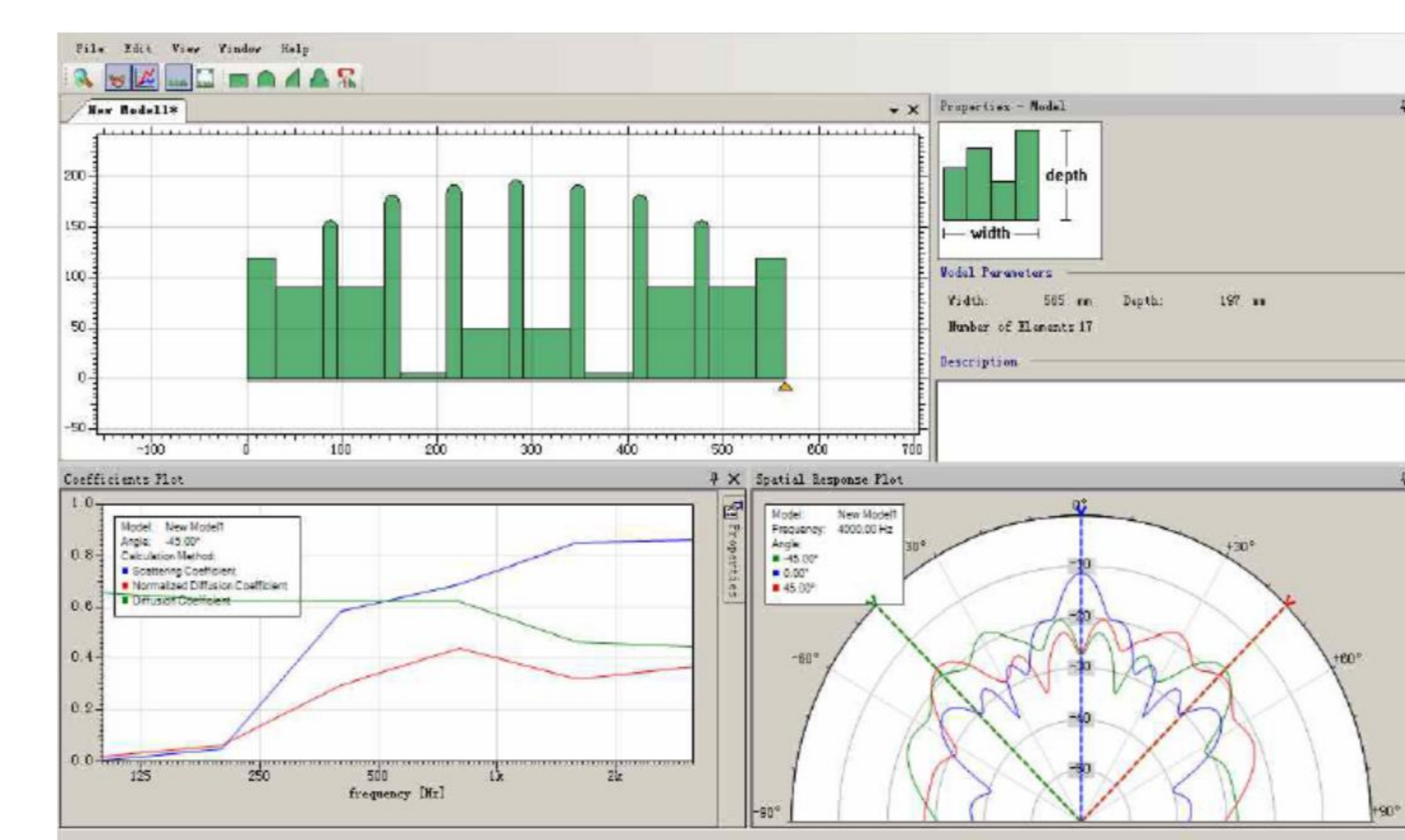
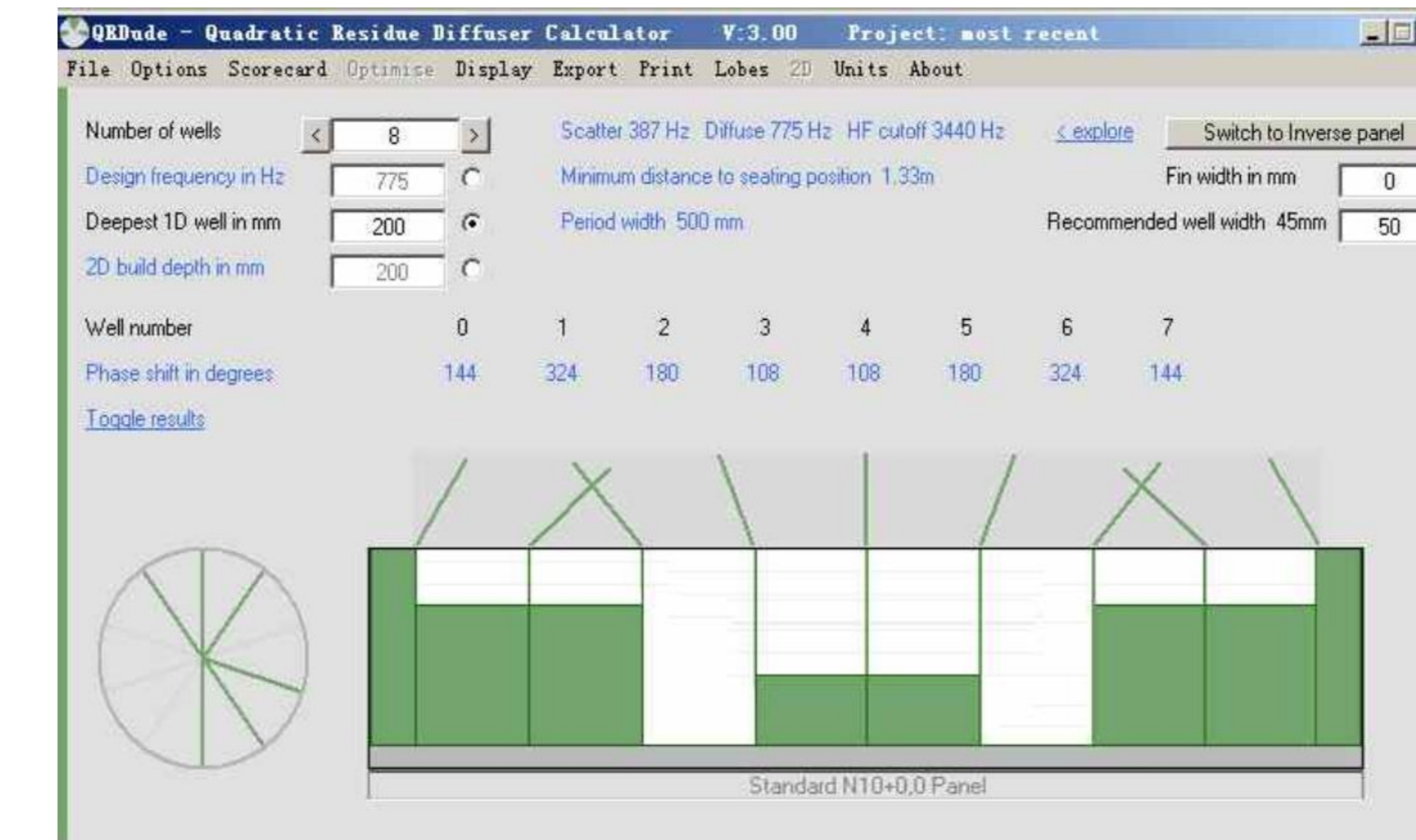



Name: Trifuser
Models: D60
Base material: Rubber solid wood
Eco-Friendly: Purely natural raw wood, PU finish paint, E0 standard
Diffusion frequency range: 491Hz-983Hz(max 2324Hz)
Weight: ~29.6Kg/pcs
Size: H1800 *W600*D100mm
Scope of Application: Opera houses, music halls, places of leisure, private theaters, recording studios, HIFI listening rooms etc.
 With high end indoor sound quality requirements for building acoustic decoration.

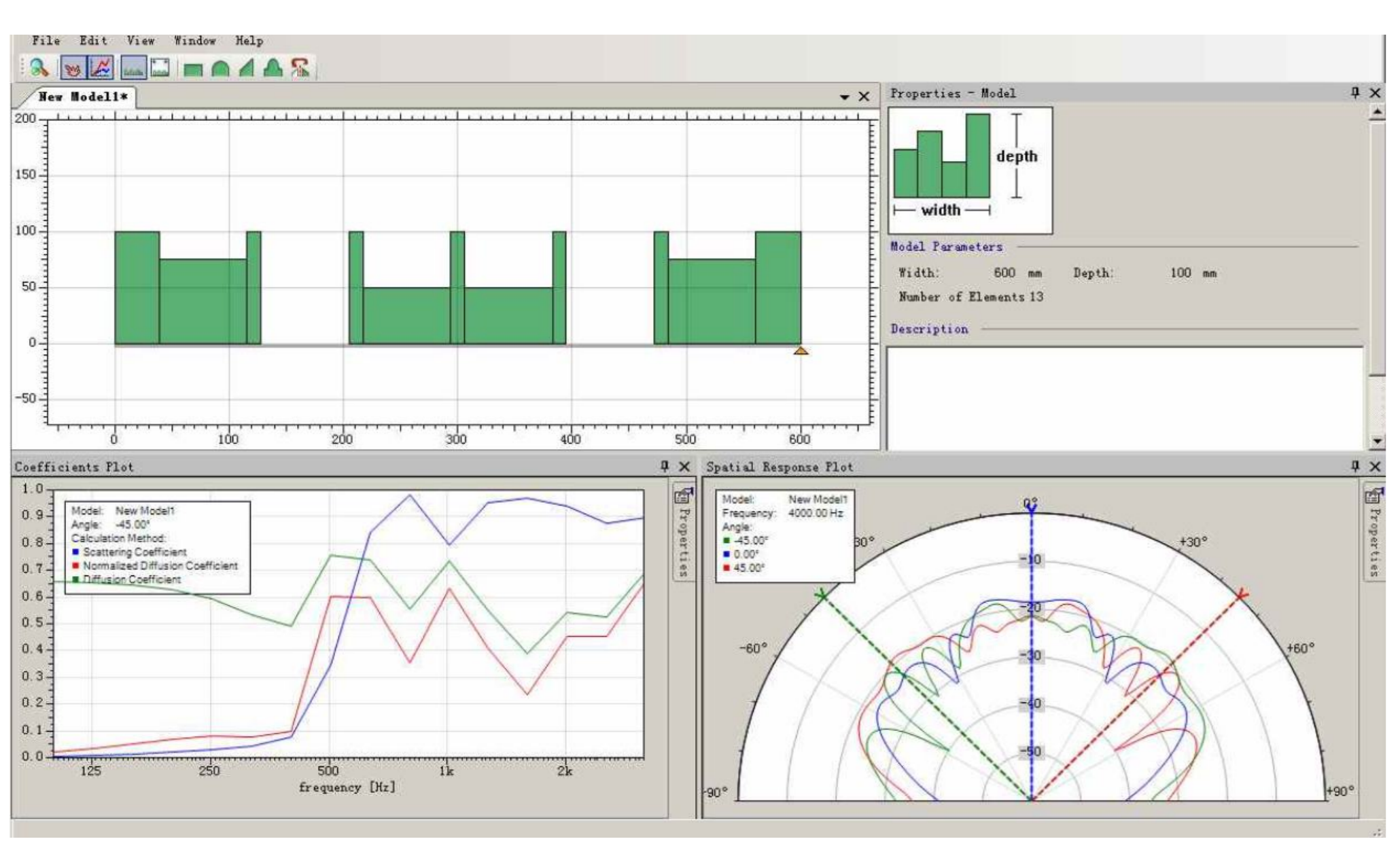
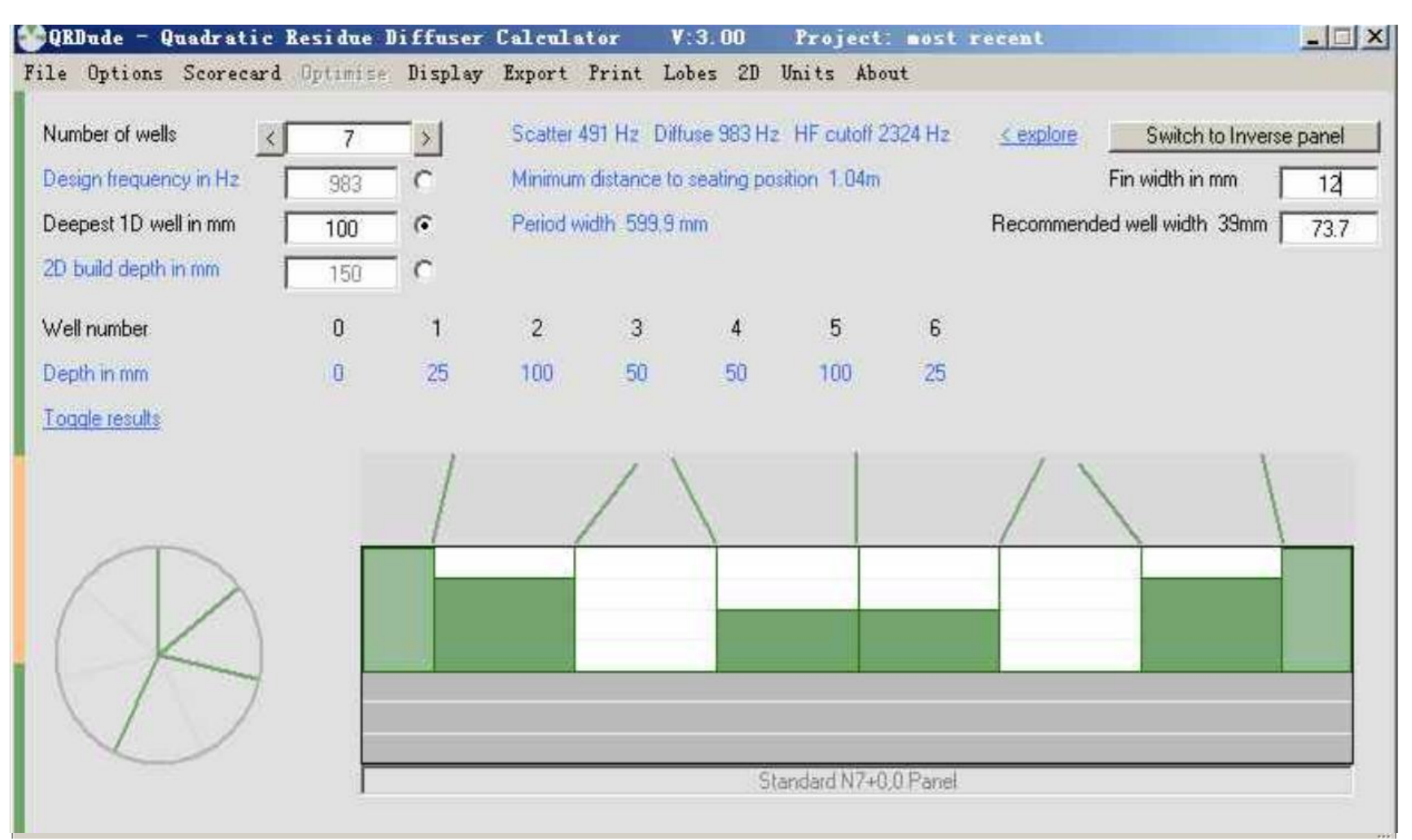
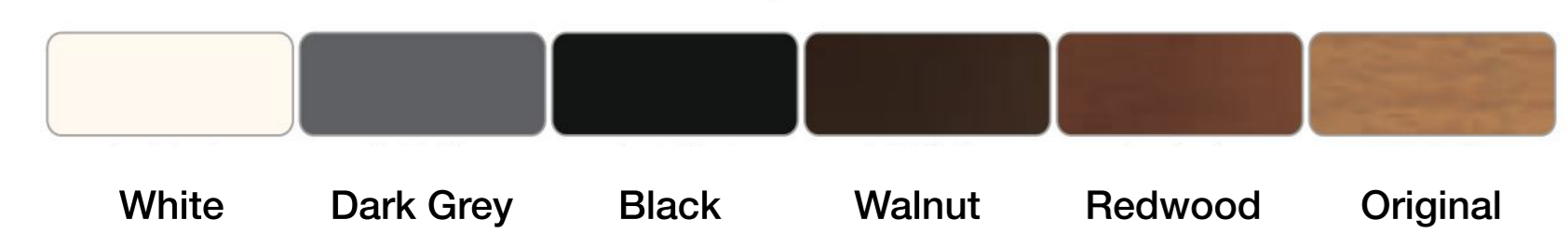

D60 solid wood diffuser is a located sequence and width enable it to have uniform theoretic formula calculation. Its groove depth and width enable it to have uniform diffuse reflections for the incident sound from different angles and all directions to make human voices more agreeable and high frequencies more gorgeous like in a large hall.

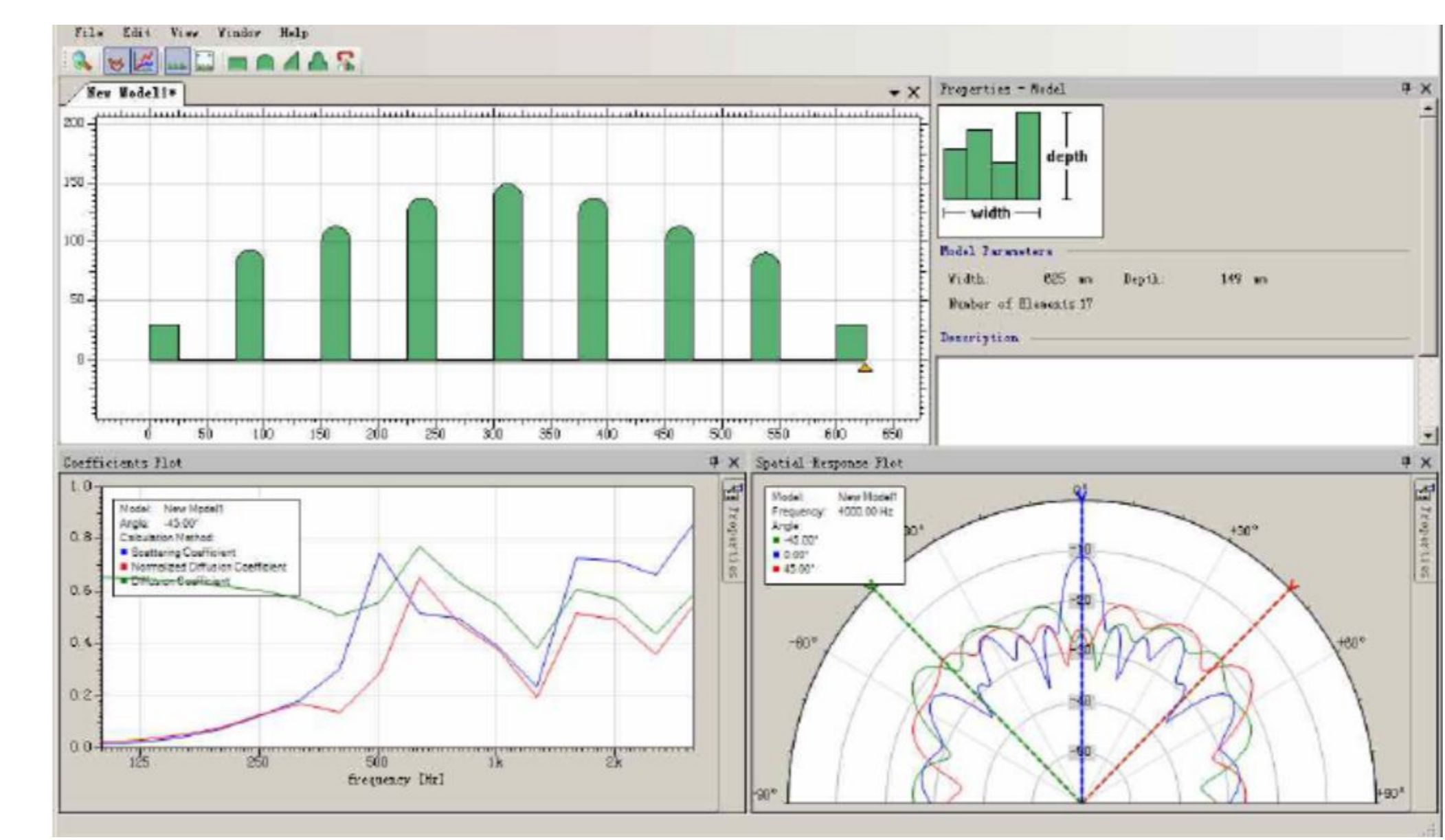
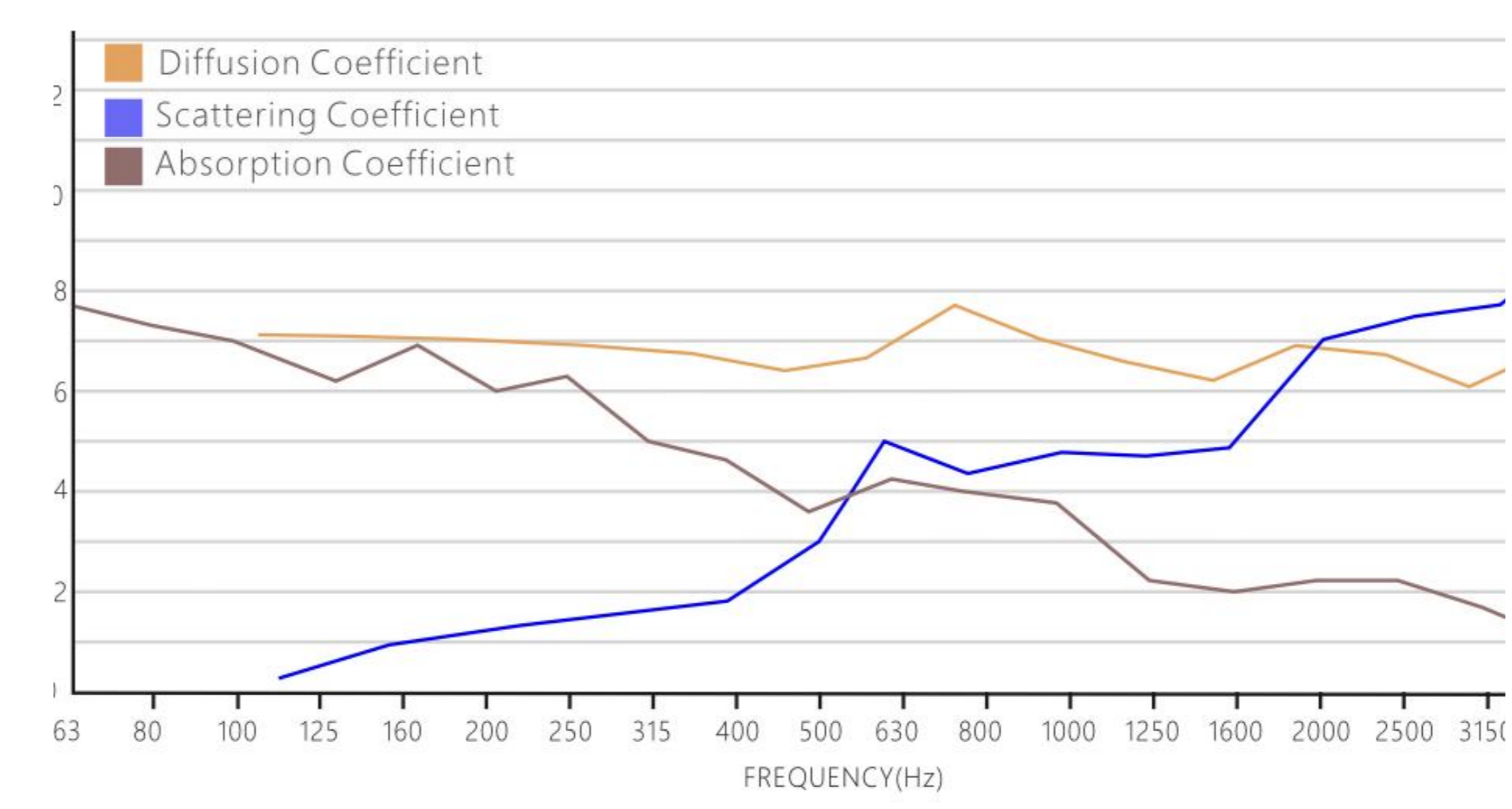
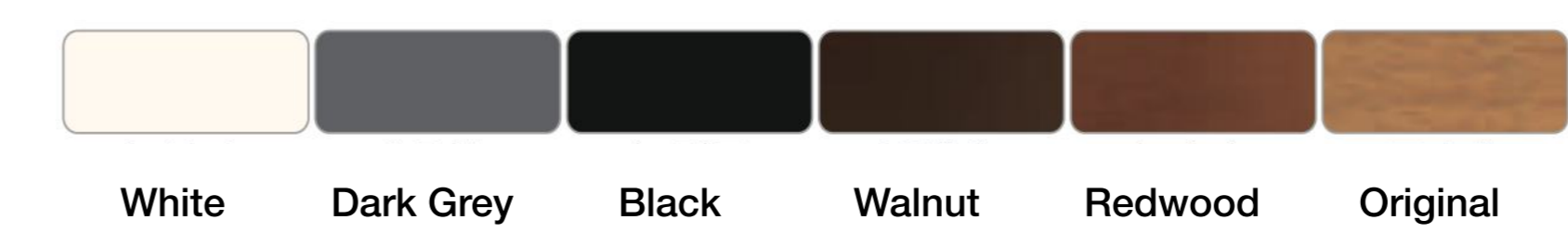

Name: Trapfuser
Models: D60W
Base material: Rubber solid wood
Eco-Friendly: Purely natural raw wood, PU finish paint, E0 standard
Weight: 32Kg/pcs
Size: H1800 *W450*D450mm
Scope of Application: Opera houses, music halls, places of leisure, private theaters, recording studios, HIFI listening rooms etc.
 With high end indoor sound quality requirements for building acoustic decoration.

D60W solid wood diffuser can be used to diffuse the sound energy, prevent echos and standing waves to realize diffusion in all direction and improve the articulation of sound. The diffusion frequency has a range of 80Hz-250Hz, reaching 63Hz minimum.





MLS 3D Diffuser

If only sound absorption measures are taken for building acoustic decoration works, the indoor space reverberation may totally disappear. Even if the sound sources are scattered at multiple points, the music or speeches still cannot reach some areas in the space, let alone the fullness of sound and sense of surrounding. The acoustic diffuser can diffuse the sound waves and sound reflection, help reduce reverberation and improve the fullness of music.

In 1975, Schroeder, a German acoustician, proposed MLS (Maximum Length Sequence) diffuser based on a type of cyclic pseudo random sequence in the number theory. MLS is the largest sequence length in the binary system, commonly seen in error correcting codes and also often used in building acoustic measurement as the single source of pseudo random noise.

The MLS diffuser is composed of a series of concave and convex grooves with equal depth. The width of the grooves is determined by the MLS sequence, '1' corresponding to convex and '0' to concave. The MLS diffusion wall surfaces design shall be based on mathematical calculations, and the results of the acoustic values as per the design scheme shall be measured in acoustic laboratories. In the audience halls of theaters, the acoustic diffusion wall surfaces are designed based on the MLS theory. The surface look irregular with concave and convex grooves, making the sound energy diffused and reflected as per the design requirements to ensure a uniform sound field in the halls to make the sound more agreeable.

EVO easy acoustic 3D diffuser is produced based on the MLS theory as well as building acoustic design data for different functions, places and specifications, and actual application experience.

It is made of GRP macromolecule engineering materials used world wide.

It can effectively and uniformly diffuse sound waves covering all areas of the space stereophonically to create hall level acoustic performance without the need for any complicated acoustic design.

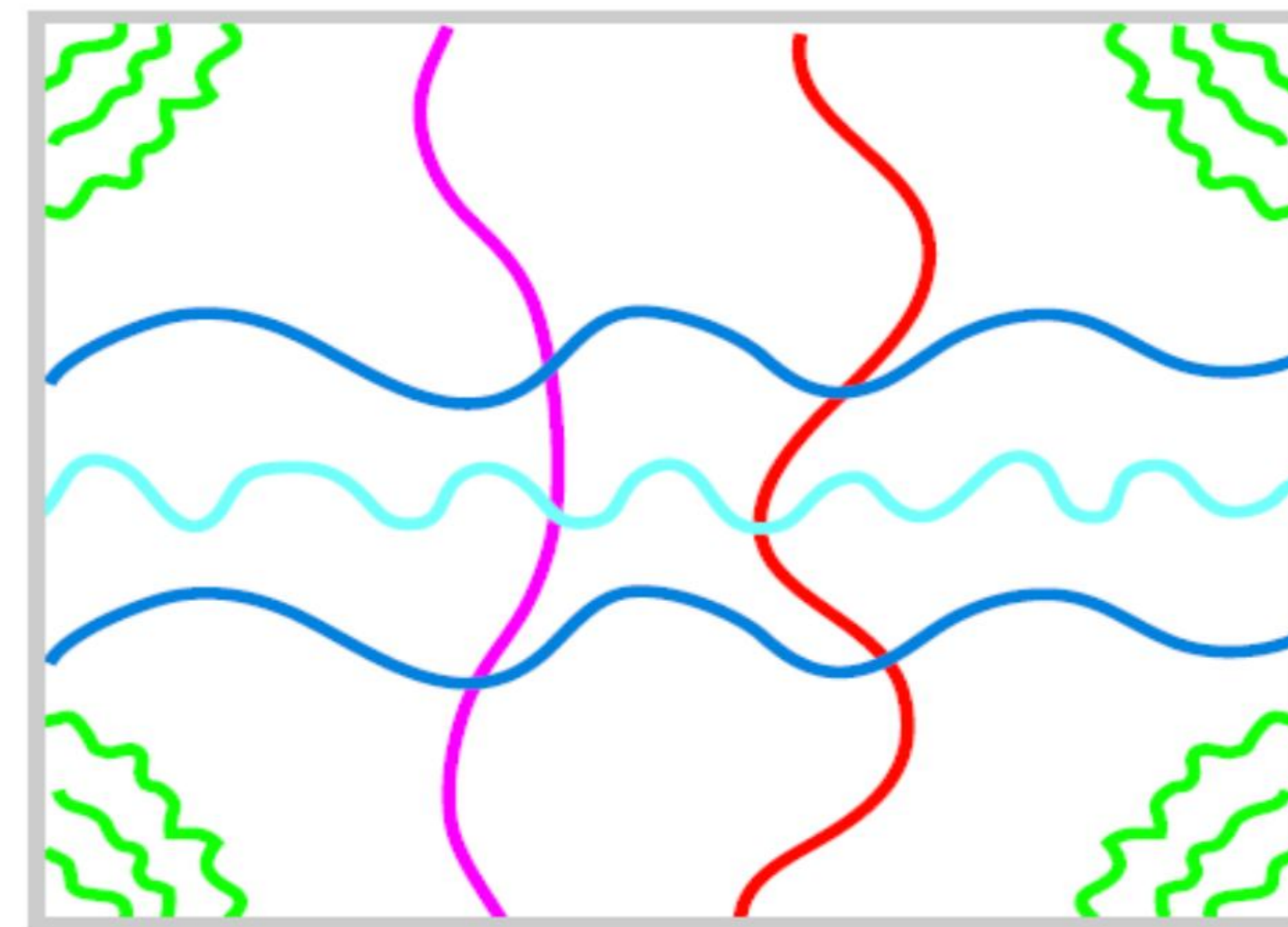
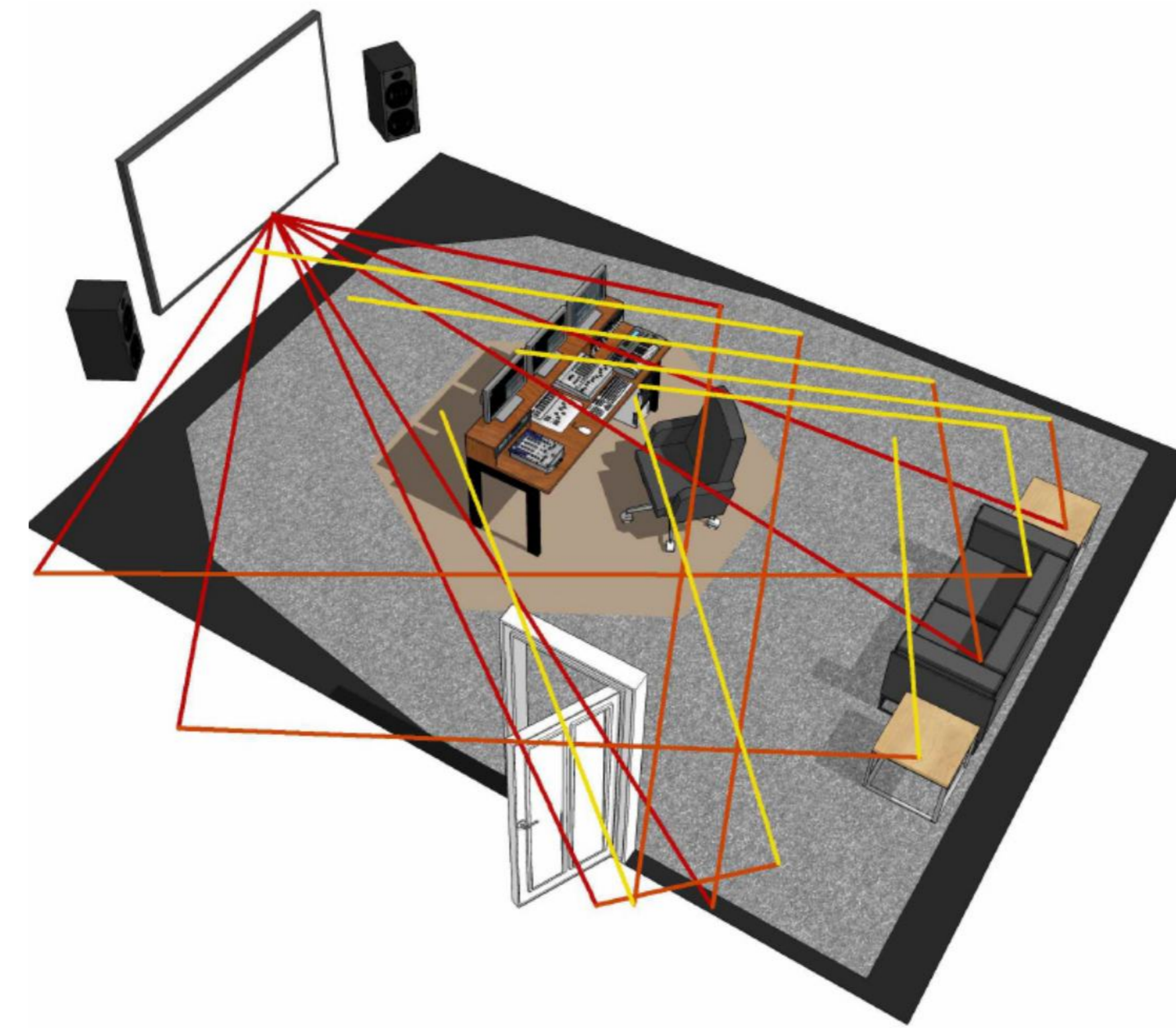

- Direct sound from sources
- Main reflections
- Secondary reflections
- Basic resonance wave
- Harmonic wave of resonance wave
- Echo effect from one side to the other
- Rapid echo effect from one side to another
- Resonance waves in corners

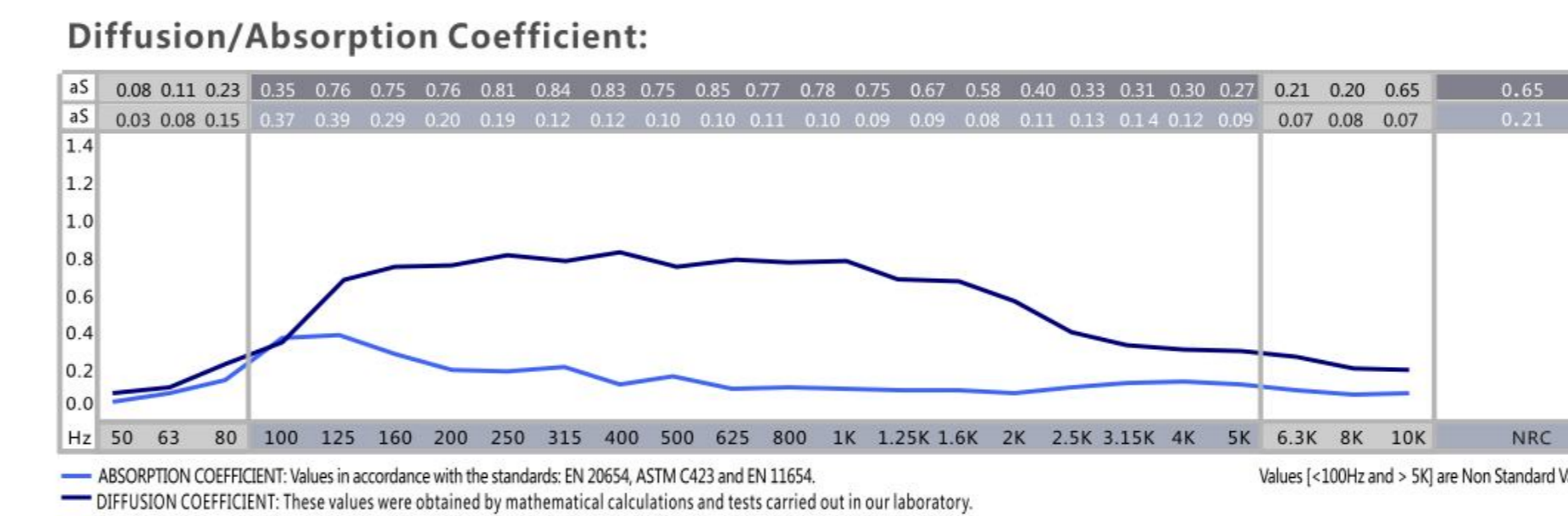
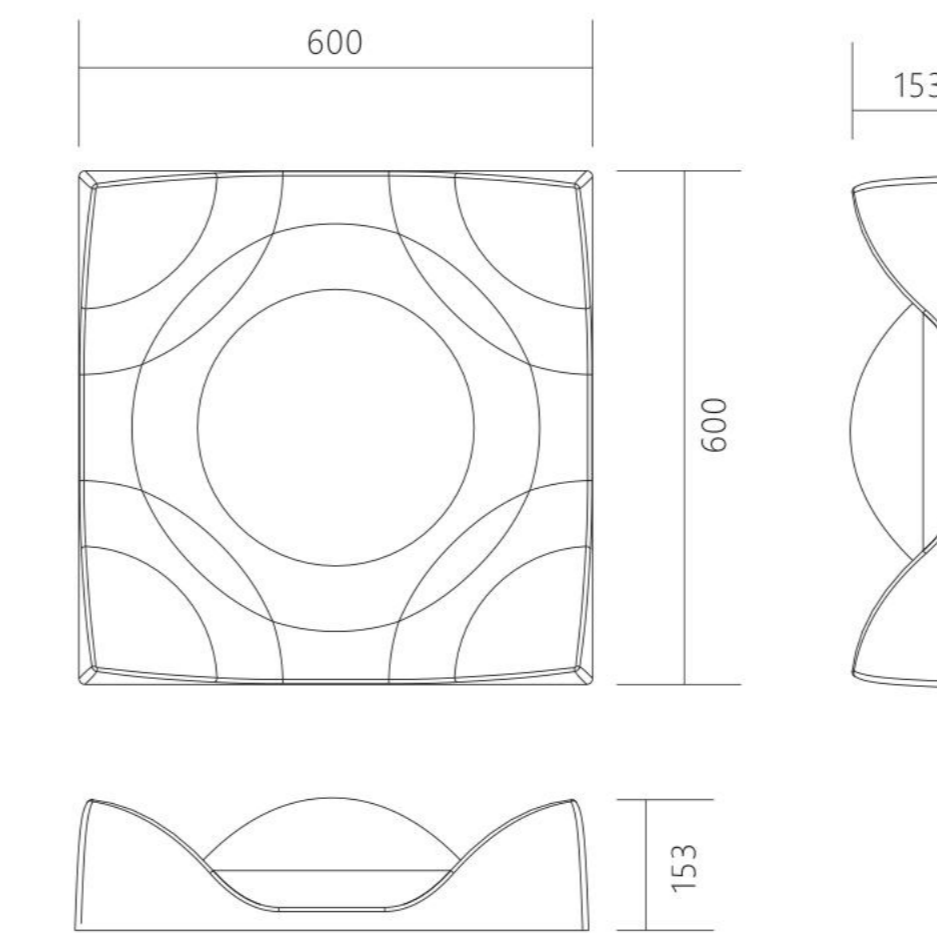
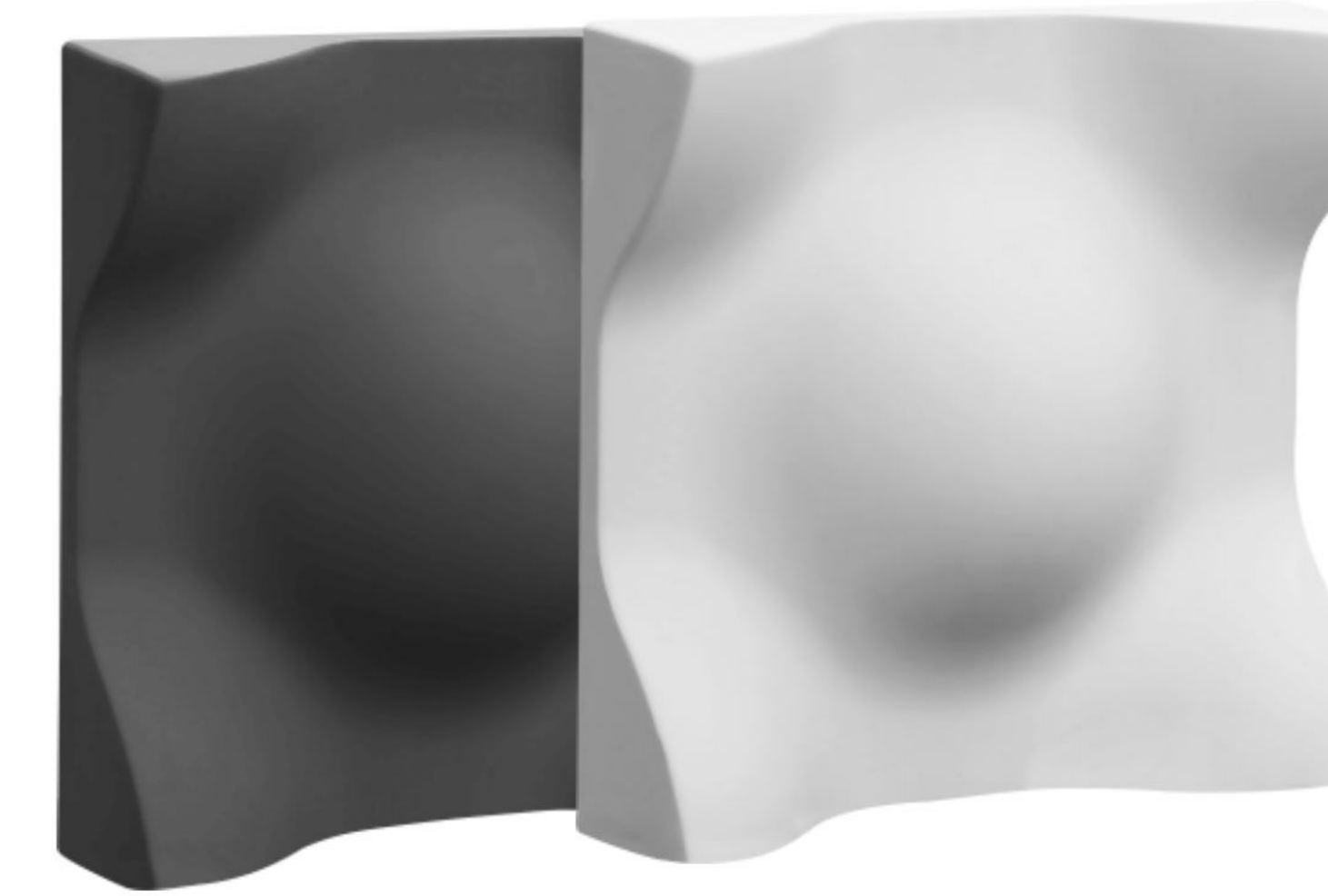

Name: Diffuser

Models: PEAK 5Q

Base material: Rubber solid wood

Eco-Friendly: PU paint, water-based paint, flocking, 100% recyclable

Diffusion indicator: 0.57 /m² [>100Hz-< 5KHz]

Weight: 8Kg/pcs

Size: H600 *W600*D153mm

Package: 2 pcs/box

PEAKS5Q convex diffuser re-distribute the reflected sound energy. Though the re-orientation is not totally taken as the theoretical value for diffusion, the convex shape provides a good acoustic control performance to distribute sound more evenly. The 180° high efficiency radiation surface help to deal with the defect of acoustic shadow in the sound amplification system, which is difficult to be covered. Various 5Q combinations are installed on the background walls of the sound amplification system to form horizontal diffusion surface to gain sound energy equivalent to 3dB. It can be used together with EQ tuning boards, and it is suitable for music halls, night clubs, KTV rooms, instrument practicing rooms etc.





Name: Diffuser
Models: CLOUD 2C / CLOUD 2C-LED(5W)
Eco-Friendly: 100% recyclable
Diffusion indicator: 0.65/m² [>100Hz-< 5KHz]
Weight: CLOUD 2C: 5.6 Kg/pcs
 CLOUD 2C-LED: 6.2 Kg/pcs
Size: H600 *W600*D90mm
Package: 3 pcs/box

Cloud fuser adopts a single asymmetrical base model with aperiodicity base-relief wave from shape. The center uniformity design provides a natural drop through high and low frequencies. The square shape provide the combination of two cloud fusers and become a symmetry reflector that keep integral and continuous diffusion.

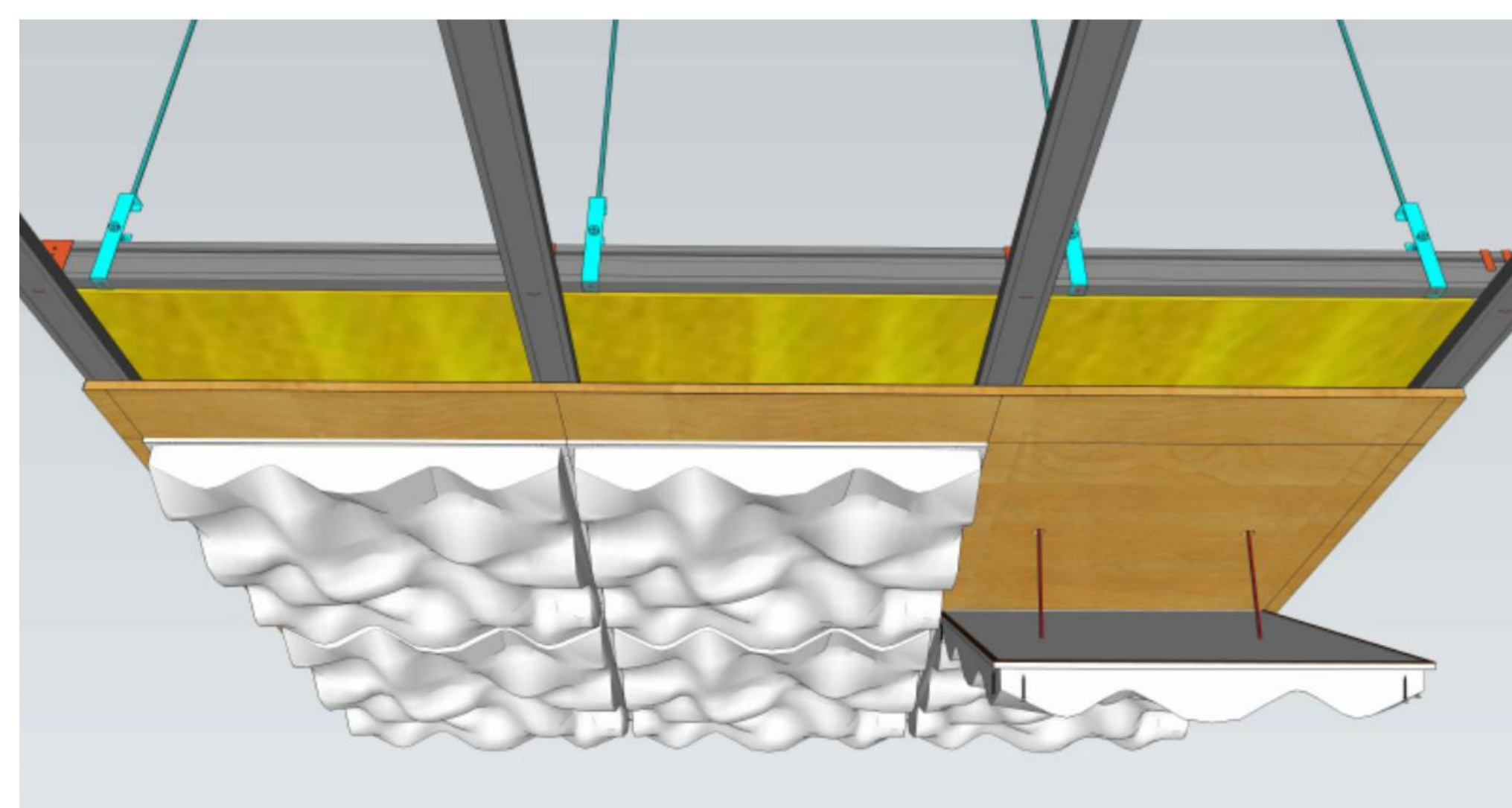
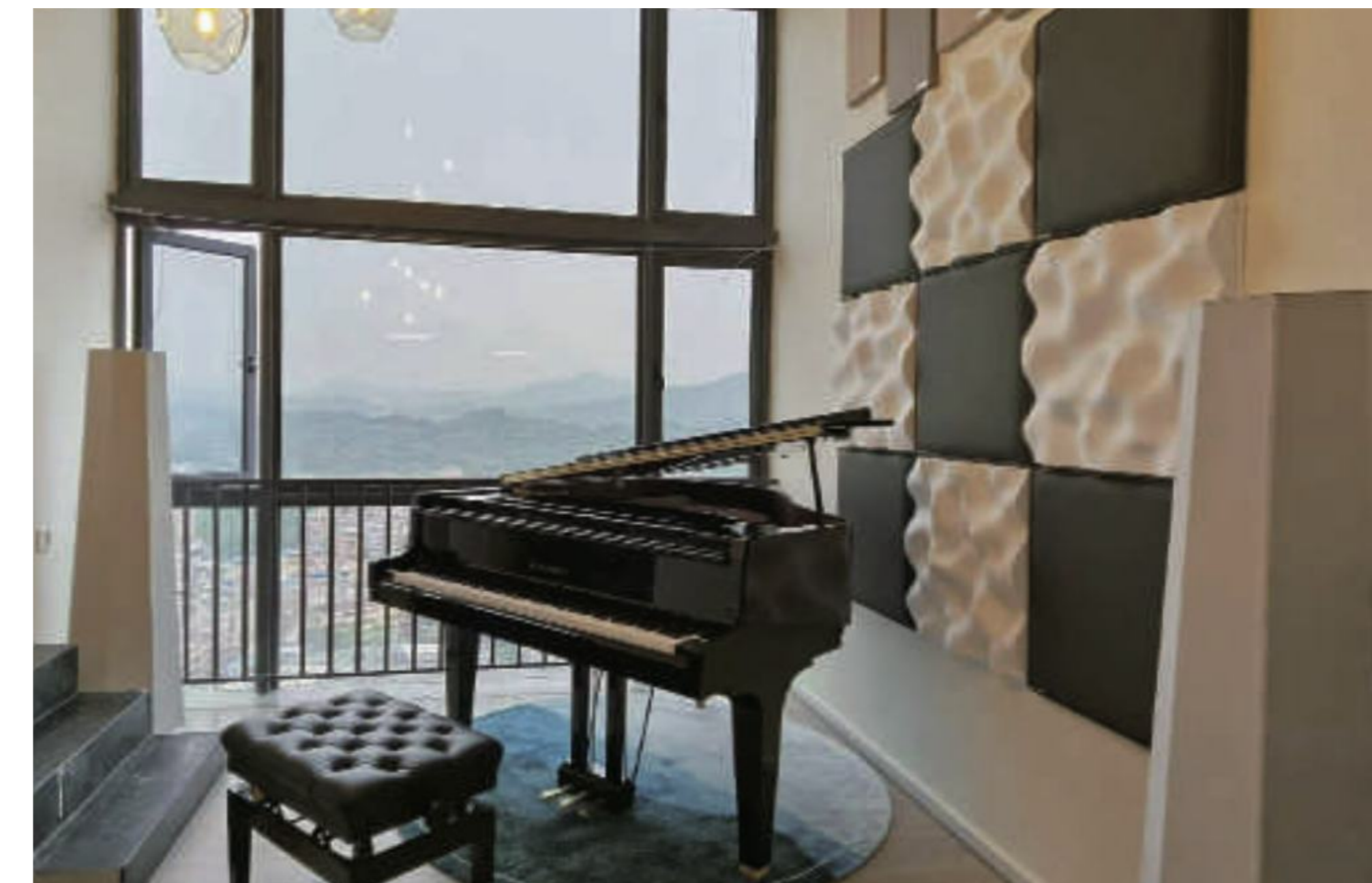
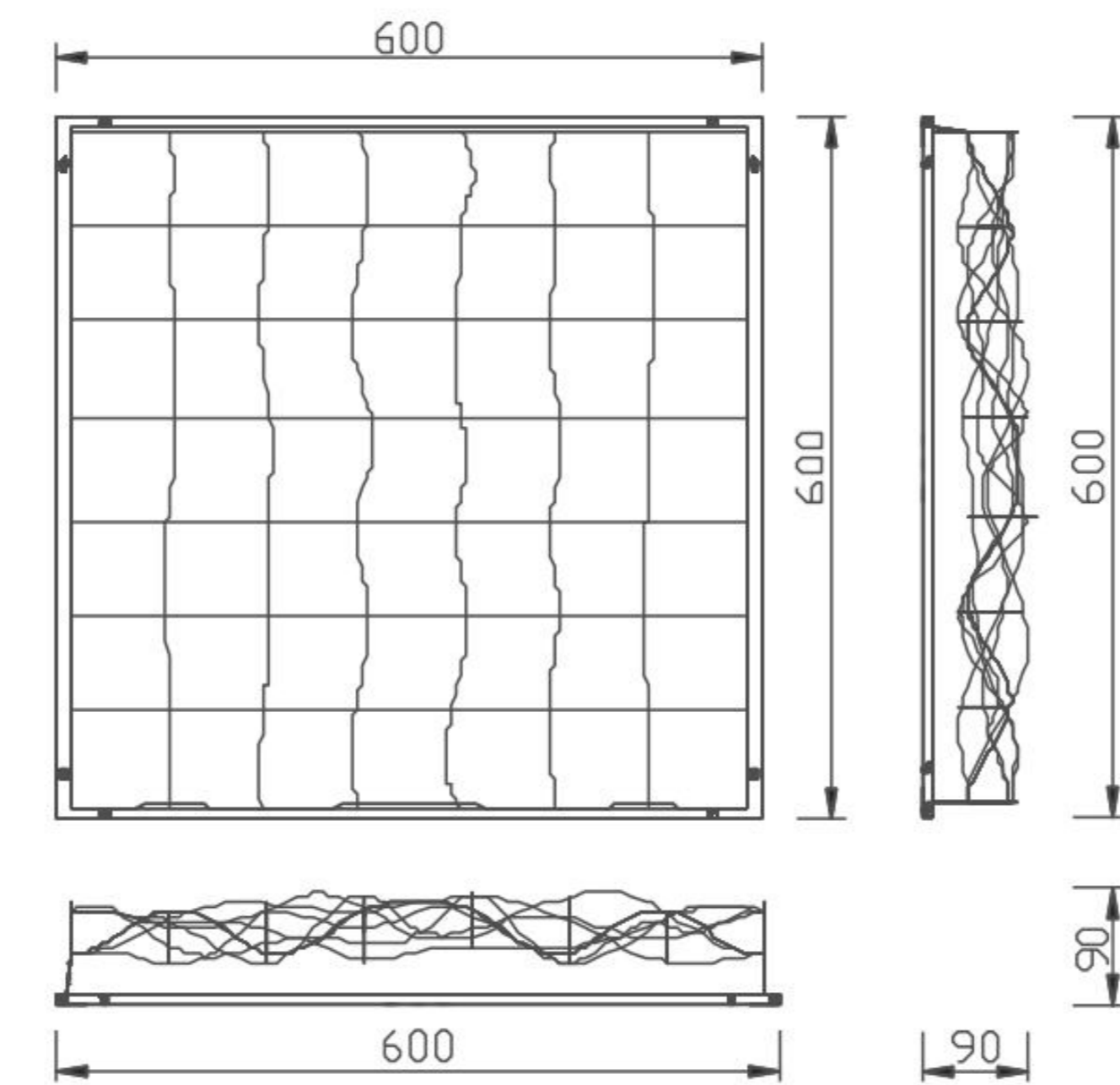
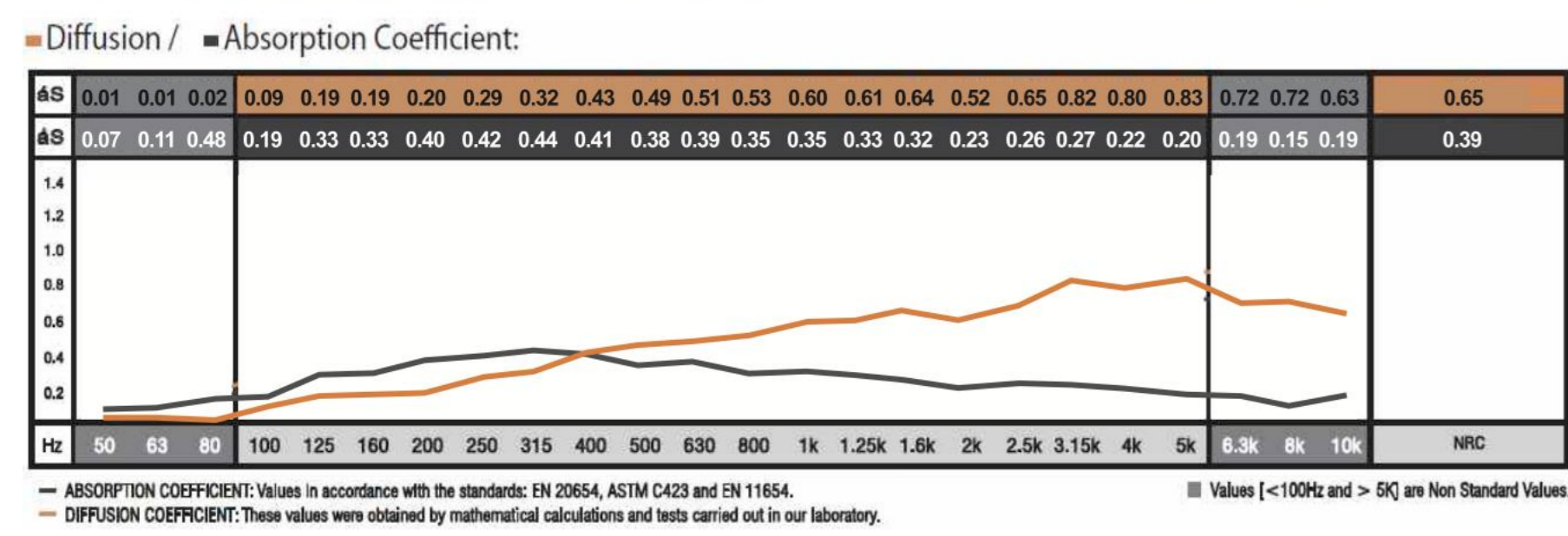
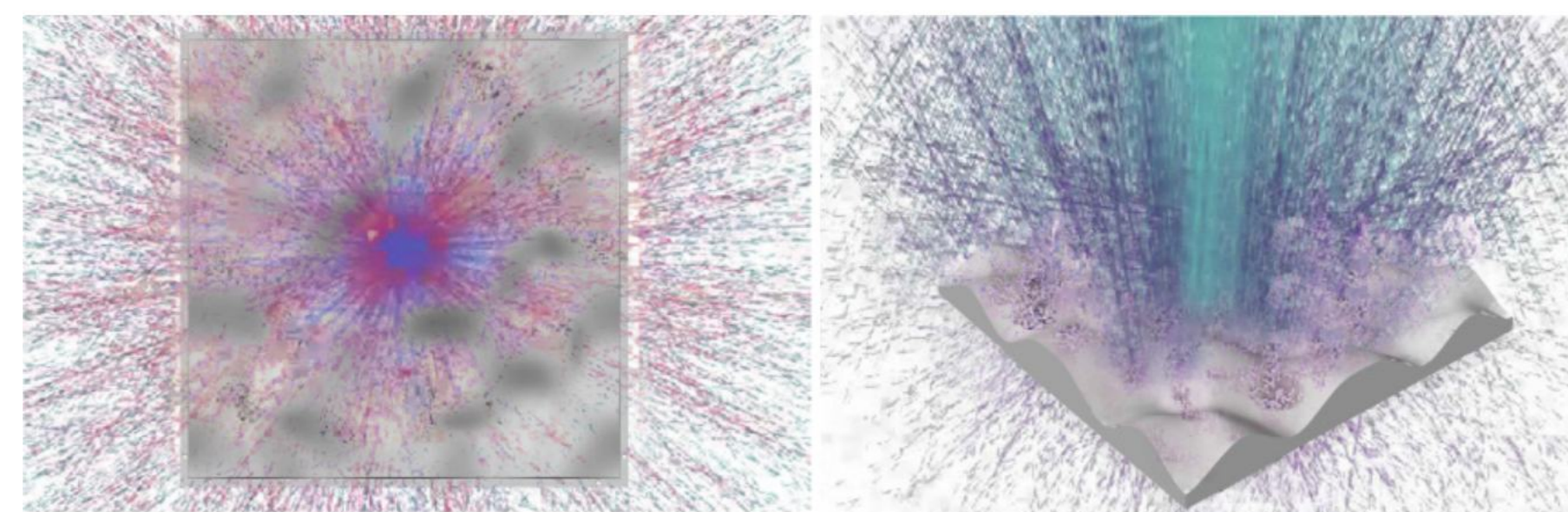

Installation Method 1:
 15mm thickness plywood on the base, and draft a size 600*600mm frame, filling 48kg/m³ rock wool backside cavity, with EVA damping rubber on the bottom and 8pcs self-tapping screw to fix it for each panel, if with LED light, please do the 12 lower voltage wire at first. Base plywood betters for lower frequency below 125Hz diffuse, which apply for the listening room and small size private home theater.

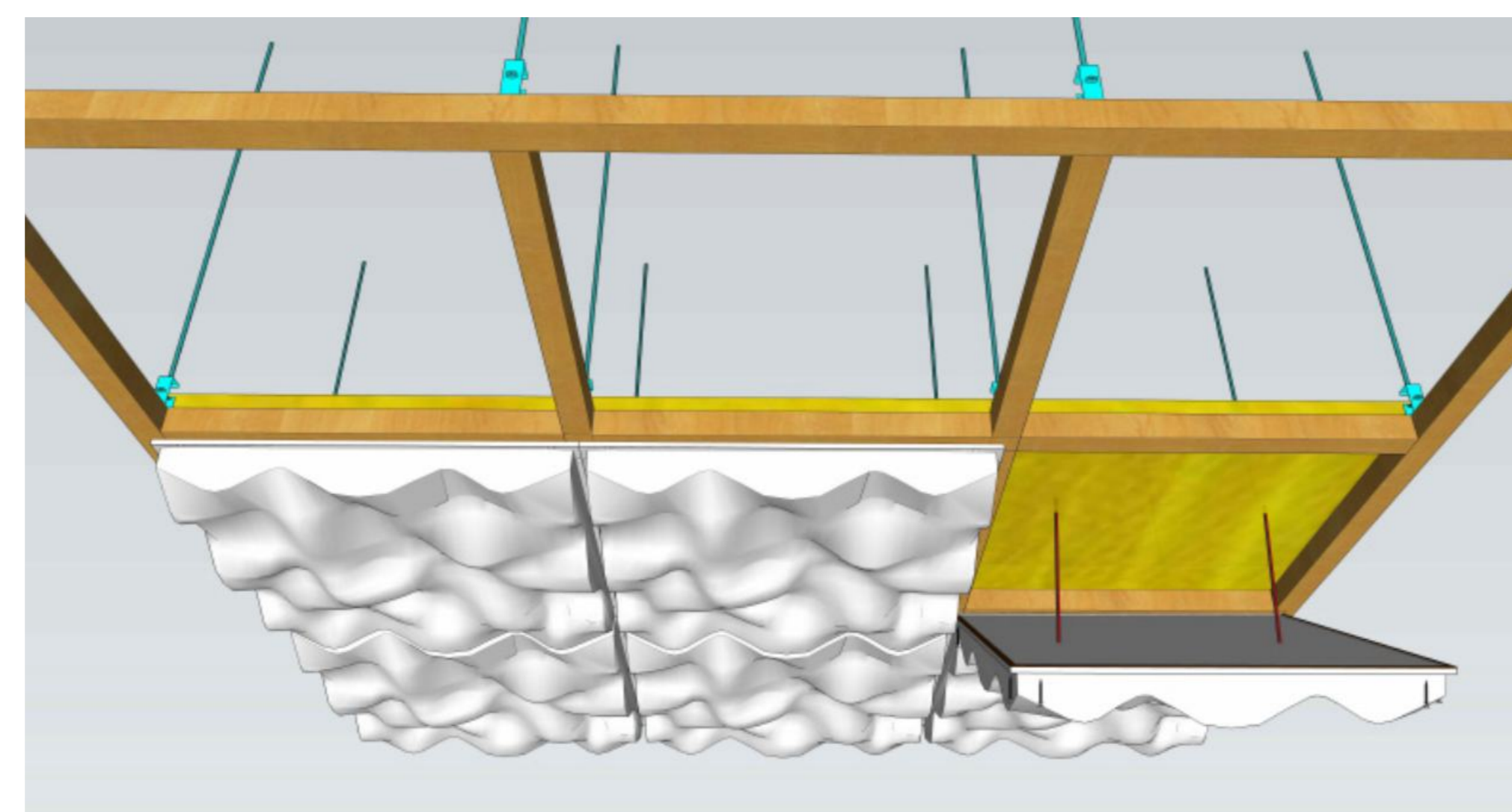

Installation Method 2:
 Installed on the size more than 40*60mm wood frame, keeping 600*600mm distance between keel's center, filling 48kg/m³ rock wool backside cavity, with EVA damping rubber on the bottom and 8pcs self-tapping screw to fix it for each panel from center to all round. If with LED light, please do the 12 lower voltage wire at first. Wooden frame cavity betters theater and bars bigger space low frequency and standing wave absorption as it helps to absorb frequency below 125Hz.

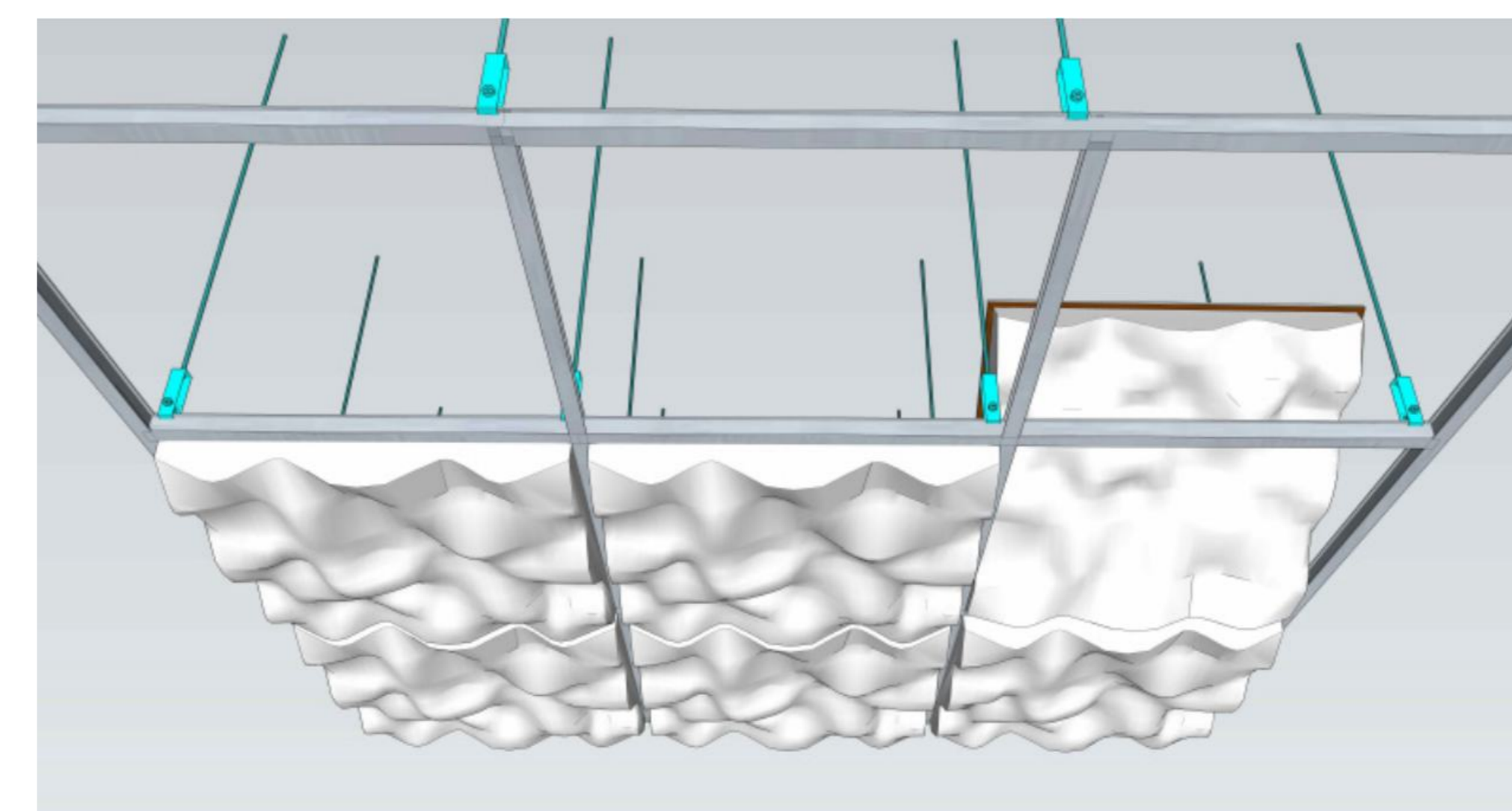

Installation Method 3: T-bar installation
 Keeping is 600*600mm distance between keel's center, with EVA damping rubber on the bottom install it from the center area to all round. If with LED light, please do the 12 lower voltage wire at first. As low cost of T-keels installation, it fits acoustic space demanding high frequency diffusion and low frequency absorption, for example, public places like churches.

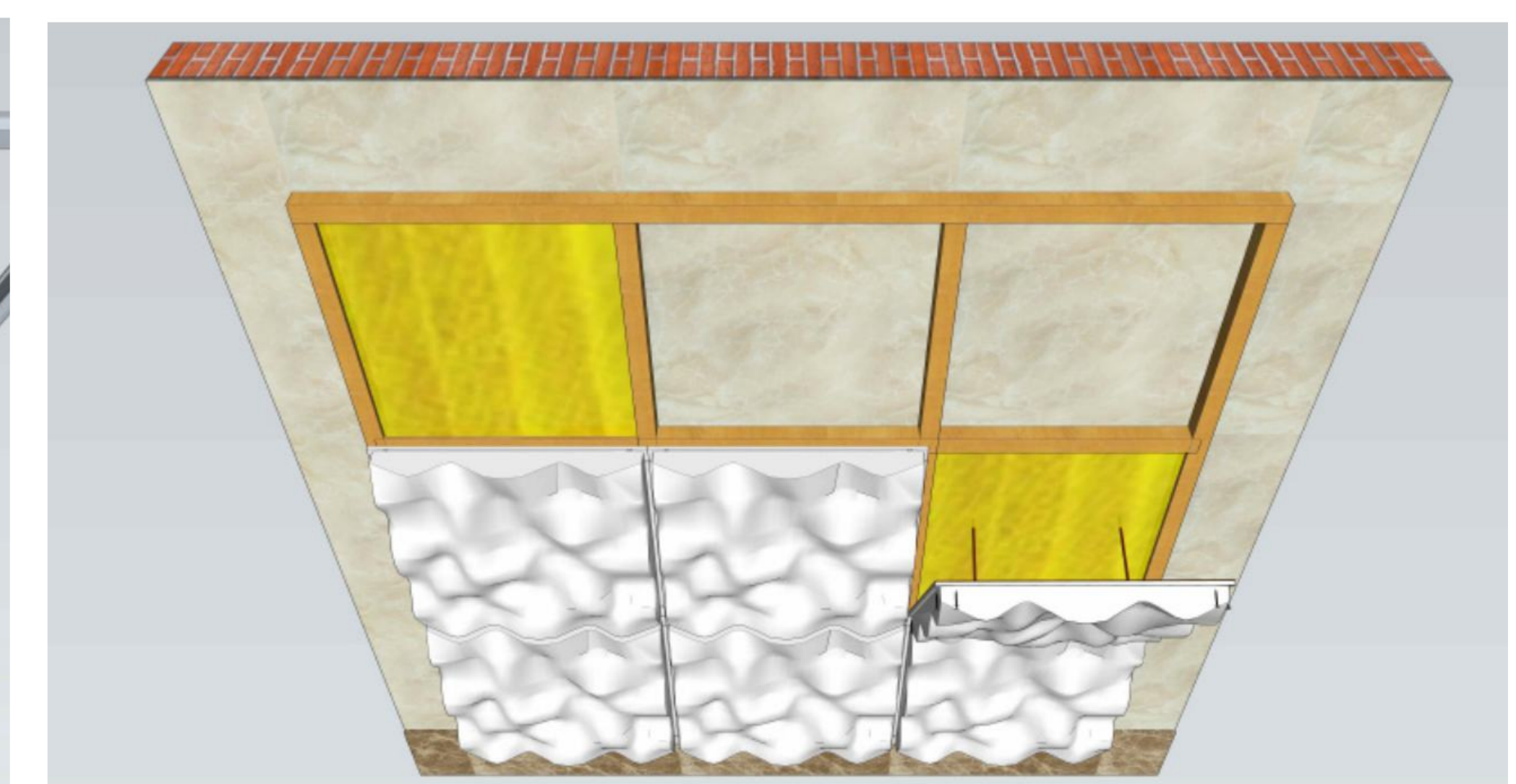

Installation Method 4: As for wood frame for wall, it is supposed to adopt wooden one which is bigger than 40X60 mm, keeping 600*600mm distance between keel's center, filling 48kg/m³ rock wool backside cavity, with EVA damping rubber on the bottom and 8pcs self-tapping screw to fix it for each panel from center to all round. If with LED light, please do the 12 lower voltage wire at first. Wooden frame in such structure betters bars and multifunctional halls low frequency and standing wave absorption as it helps to absorb frequency below 250Hz.



Name: ARC diffuser (Bass trap)
Models: ARC 300W
Base material: Carbon polymer composite material
Finish: Hot coated PP
Eco-Friendly: E0 standard
Weight: H1200~11.5Kg / H1500~14.4Kg / H1800~17Kg
Size: H1200/1500/1800 *W300*D300mm
Application: multifunctional hall, private cinema, recording studio, HIFI rooms etc.

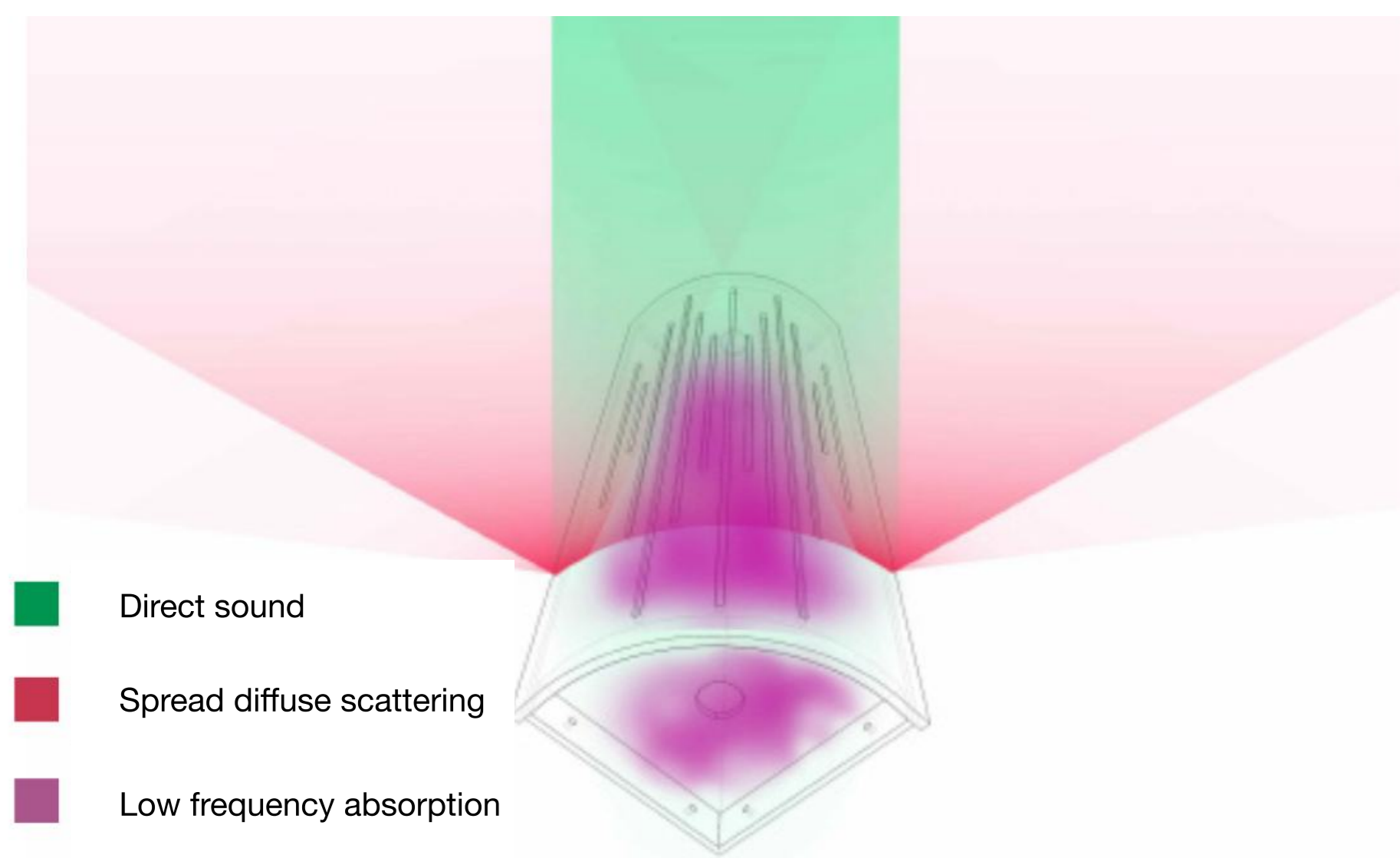
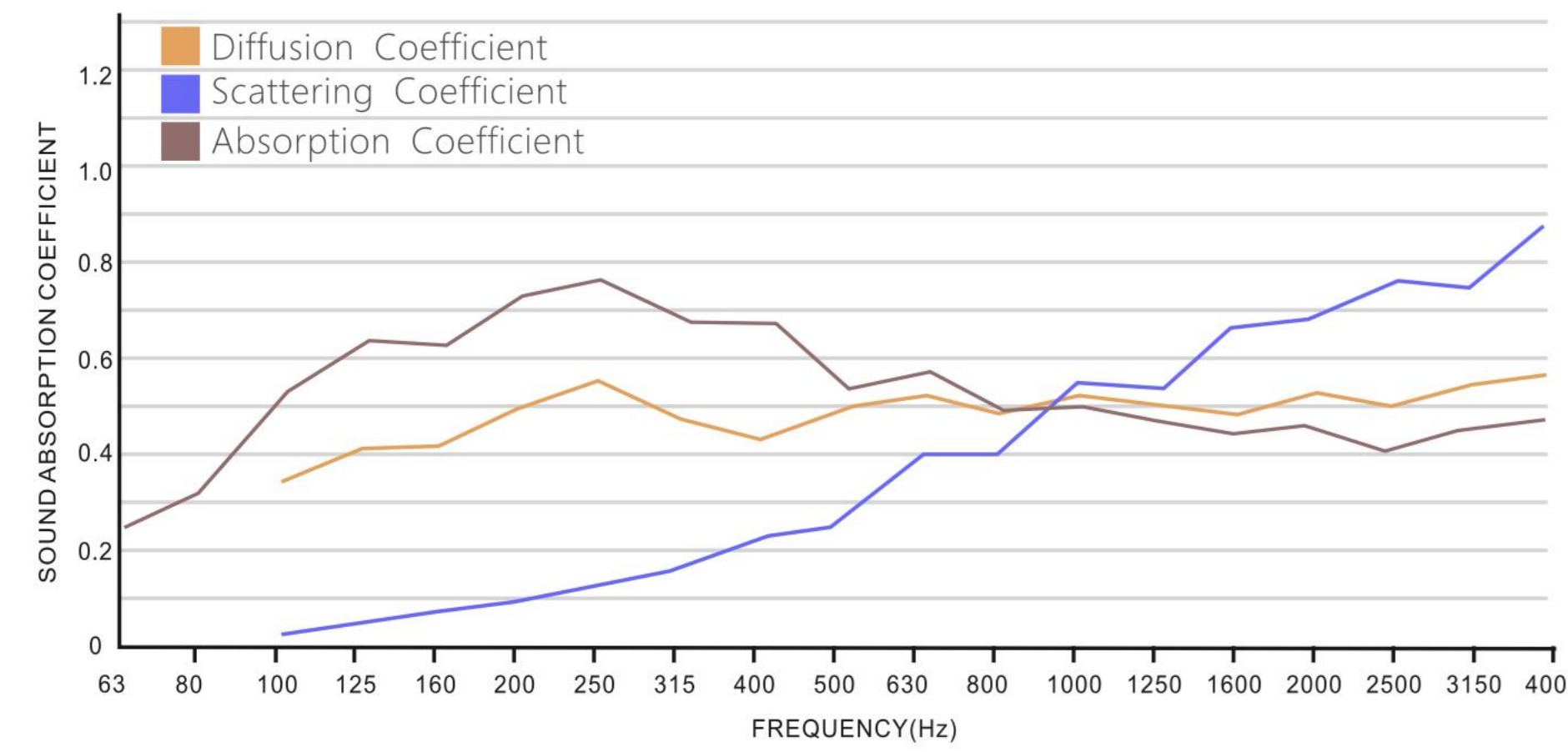

A 90° curve diffusing surface using hot mold without glue, 20% different slot for absorbing broadband frequency. Inside there is a triangle low frequency absorbing cavity, filled with green acoustic material to absorb standing waves at 250Hz effectively. At the same time this cavity scatters beneficial sound energy gathered in corners. These factors minimize sound energy consumption from the acoustic system.

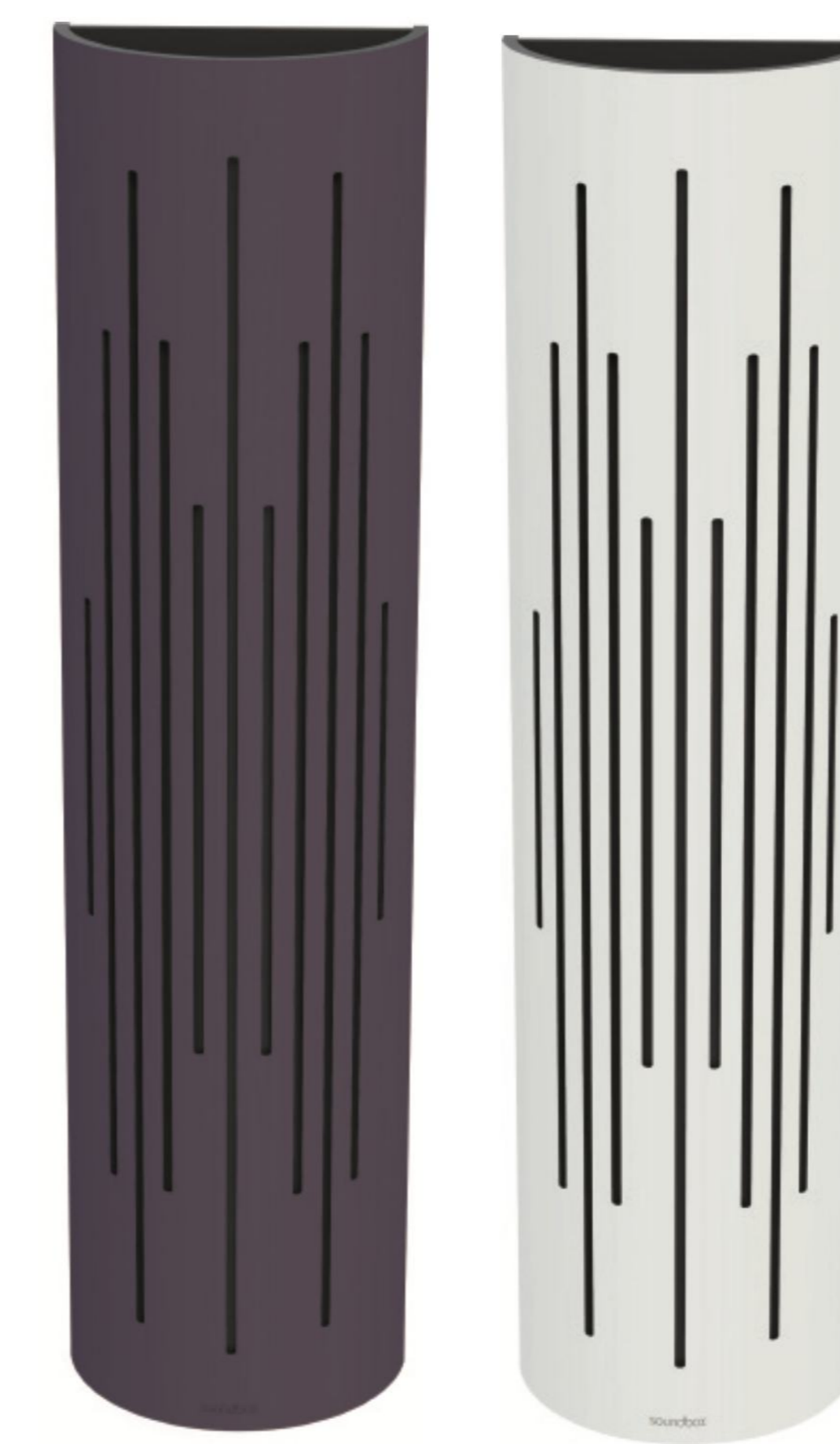
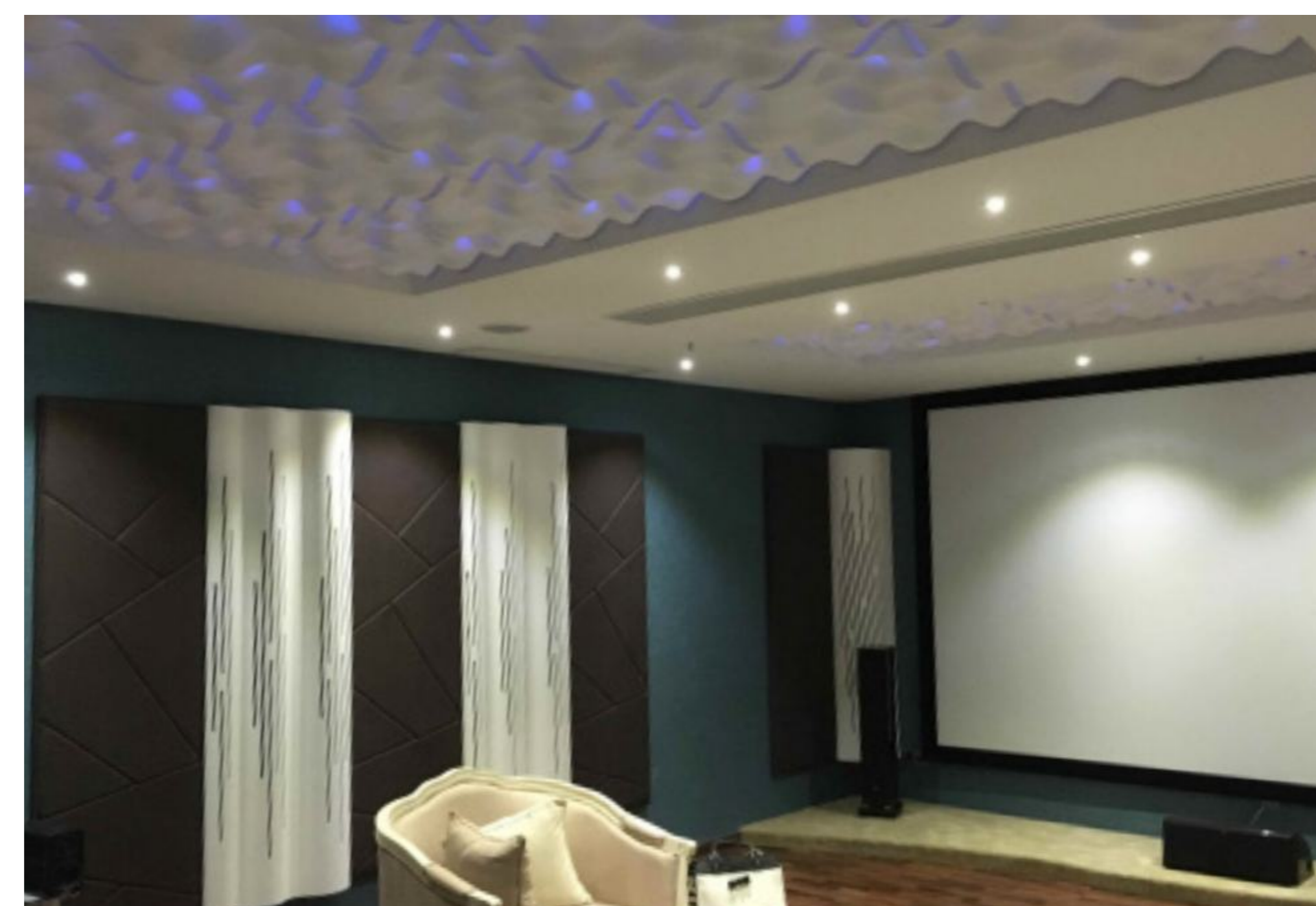

Name: ARC diffuser (Bass trap)
Models: ARC 300
Base material: Carbon polymer composite material
Finish: Hot coated PP
Eco-Friendly: E0 standard
Weight: H600~5Kg / H1200~9.23Kg / H1500~11.7Kg / H1800~14Kg
Size: H600/1200/1500/1800 *W300*D150mm
Application: multifunctional hall, private cinema, recording studio, HIFI rooms etc.

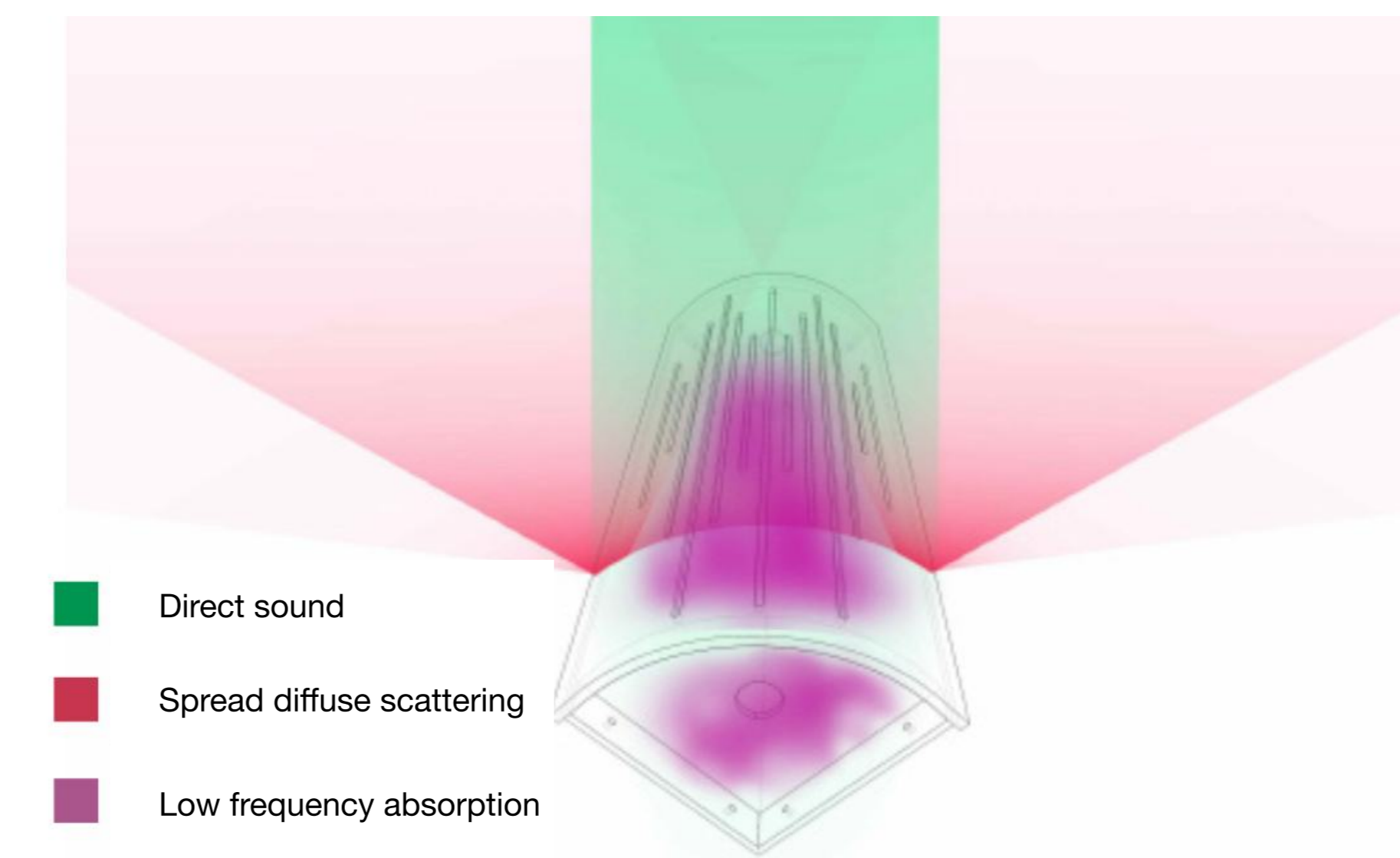
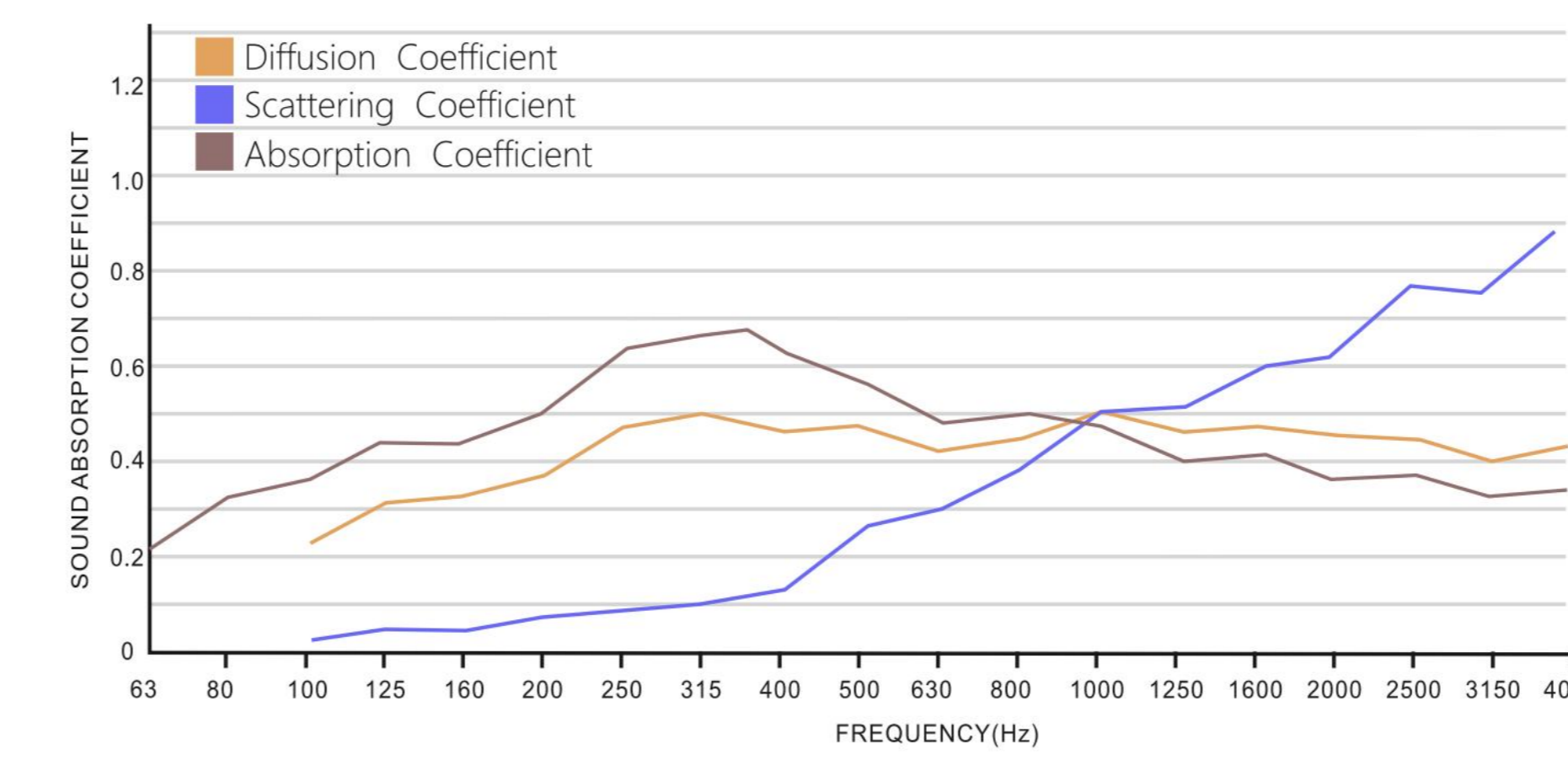
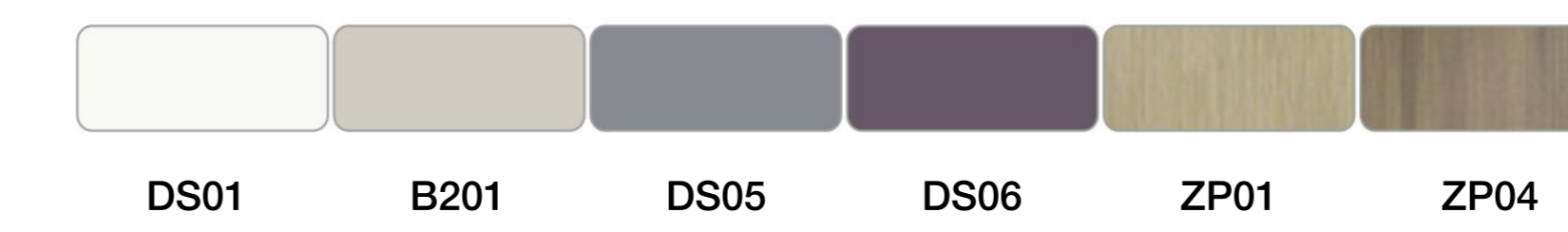

A 180° curve diffusing surface using hot mold without glue, 20% different slot for absorbing broadband frequency. Inside there is an unbalanced low frequency absorbing cavity, filled with green acoustic material to absorb margin sound below 350Hz effectively. The reflected sound will fully diffused in a certain direction, this way not only sound energy consumption is saved but also a relatively balanced acoustic environment is obtained.

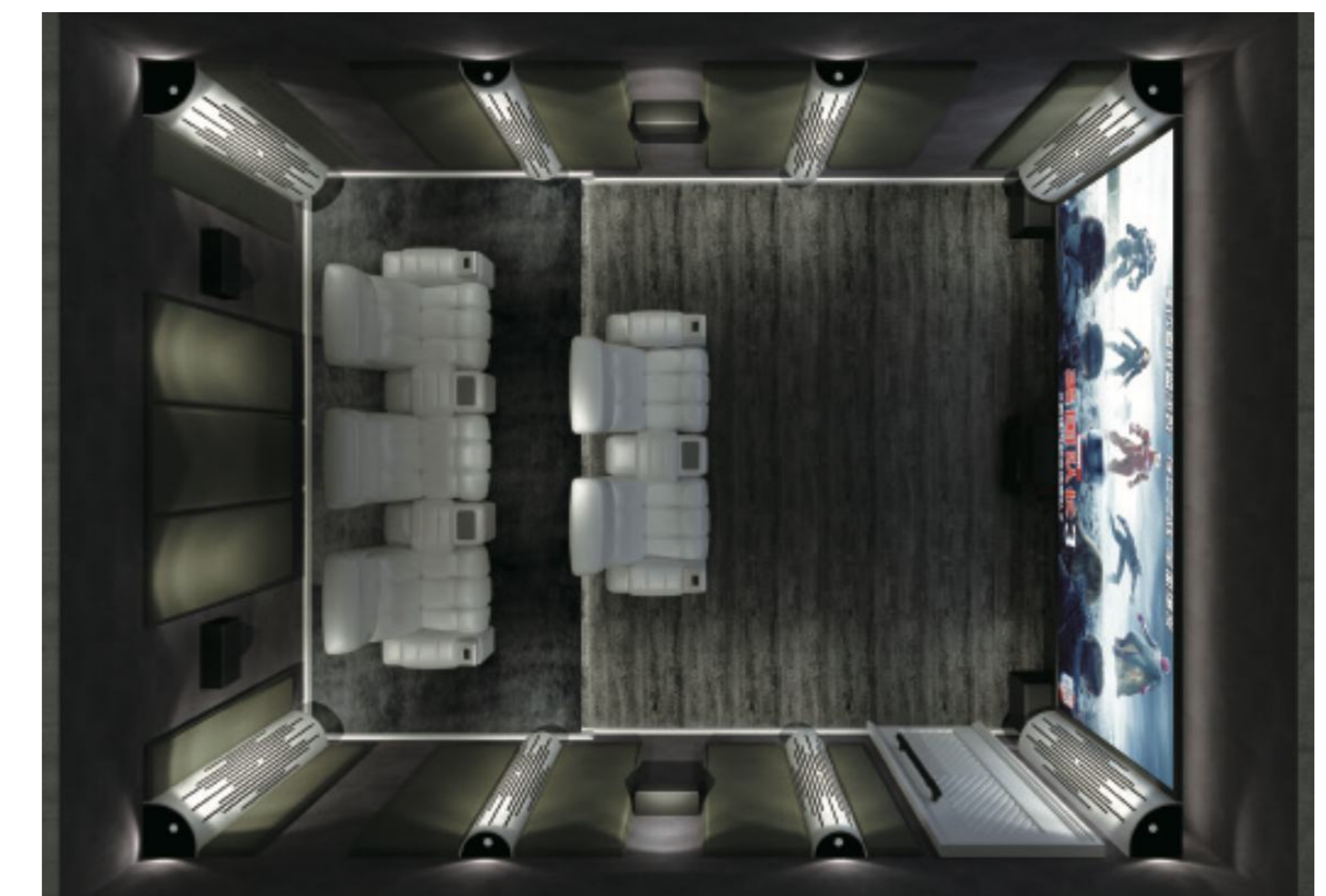

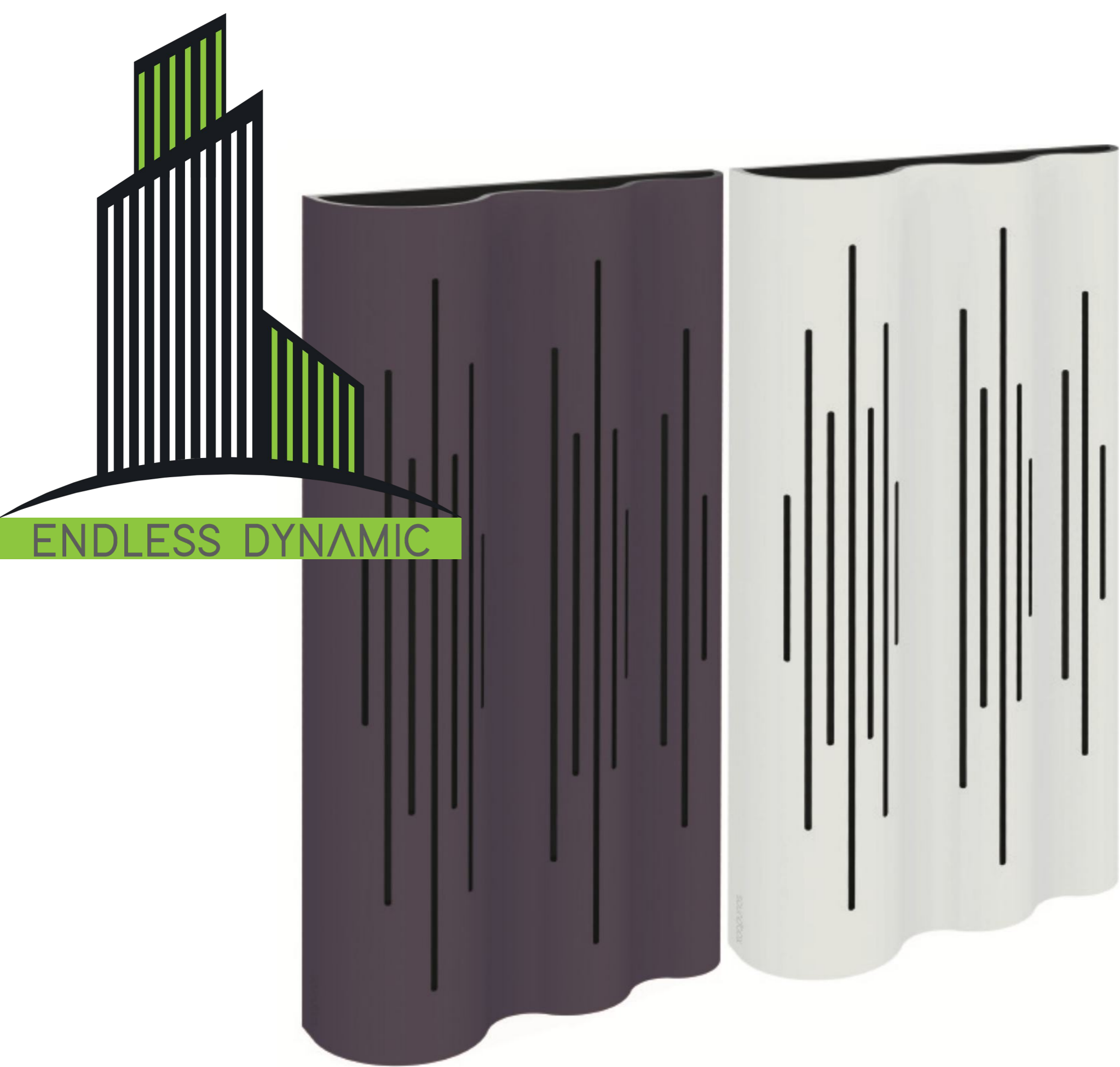

Name: Diffuser

Models: Wave 600

Base material: Carbon plastic composite

Finish: Heating compound PP veneer

Eco-Friendly: E0 standard

Weight: H600~9.5Kg / H1200~19Kg / H1500~23Kg / H1800~28Kg

Size: H600/1200/1500/1800 *W600*D160mm

Application: Sound quality decoration in high-end indoor spaces: Concert halls, multifunctional hall, private cinema, recording studio, HIFI rooms etc.

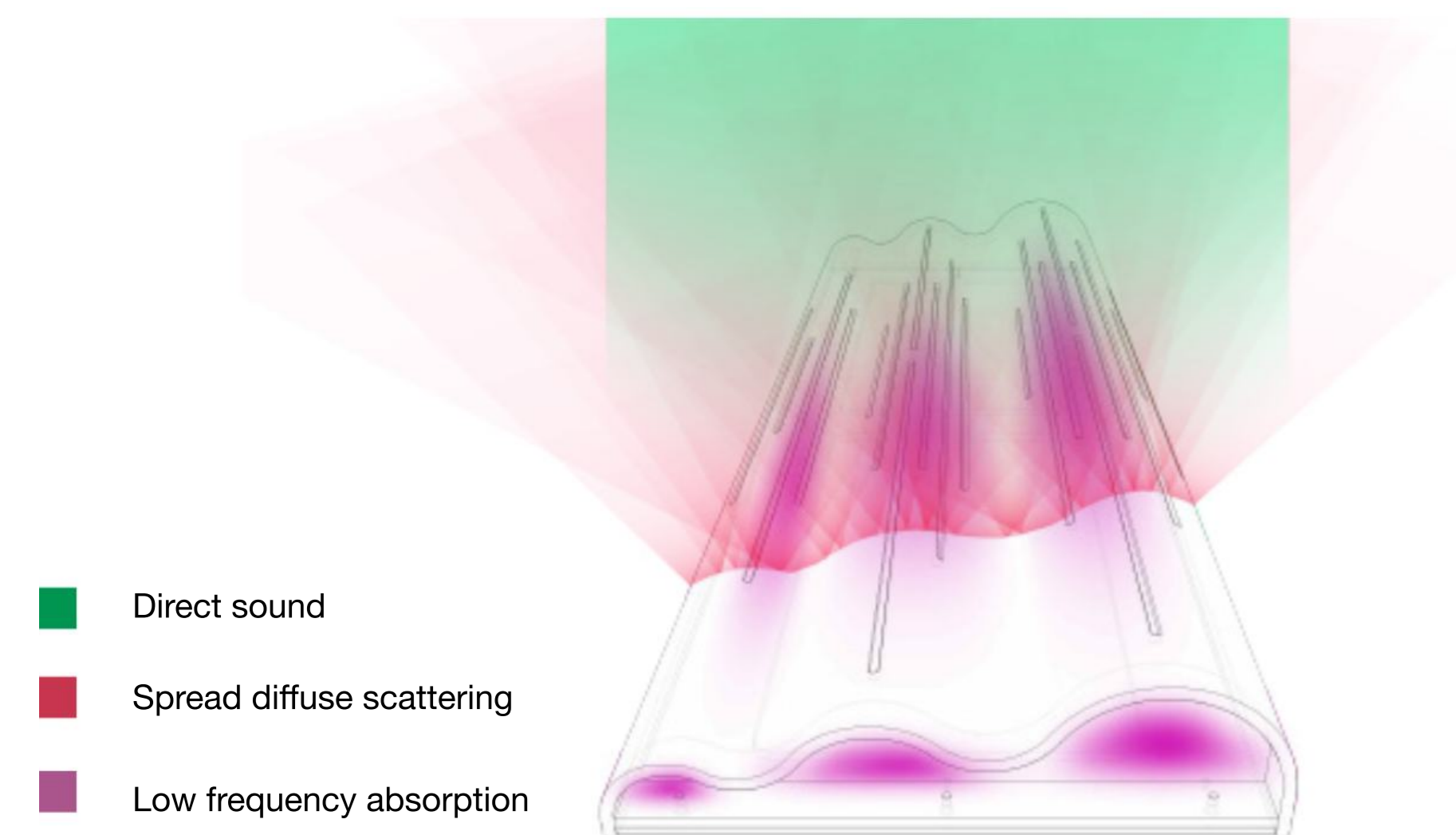
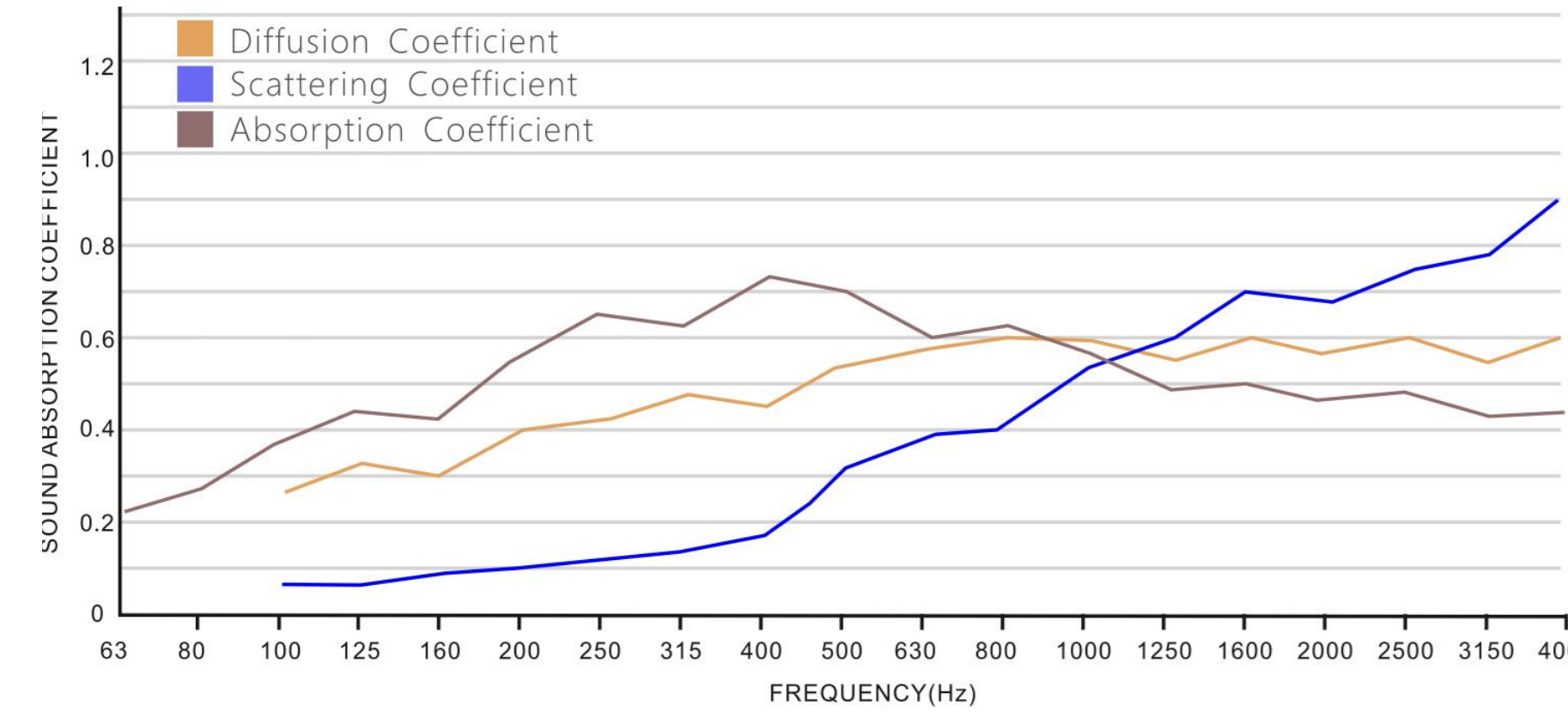

Three wave-shaped diffusion with superimposed double-range bands, Sound absorption with 20% asymmetric design, built-in low-frequency (550-250Hz) absorption cavities with three unequal volumes.

The MLS diffuser horizontally scatters and balances the reflected sound resulting in a more uniformed sound environment without losing sound energy.

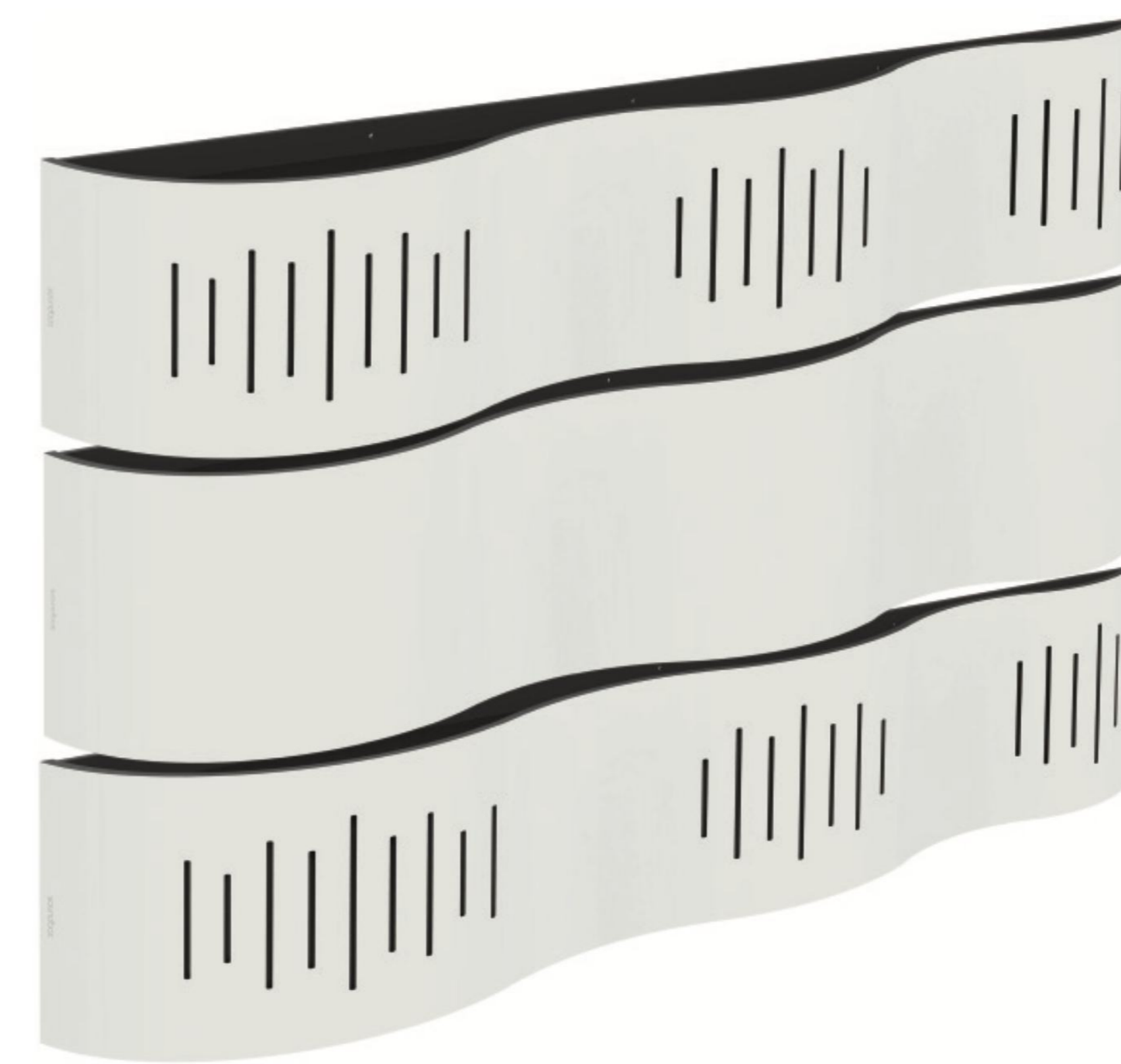

Name: Diffuser

Models: PEAK 2000A / D (A-sound absorption & diffuser / D-diffuser only)

Base material: Carbon plastic composite

Finish: Heating compound PP veneer

Eco-Friendly: E0 standard

Weight: PEAK 2000A: W800 ~ 42.5Kg / W400 ~ 32Kg
PEAK 2000D: W800 ~ 43.3Kg / W400 ~ 22Kg

Size: PEAK 2000A: H2000*W800/400*D200mm
PEAK 2000D: H2000*W800/400*D200mm

Application: Sound quality decoration in high-end indoor spaces: Concert halls, multifunctional hall, private cinema, recording studio, HIFI rooms etc.

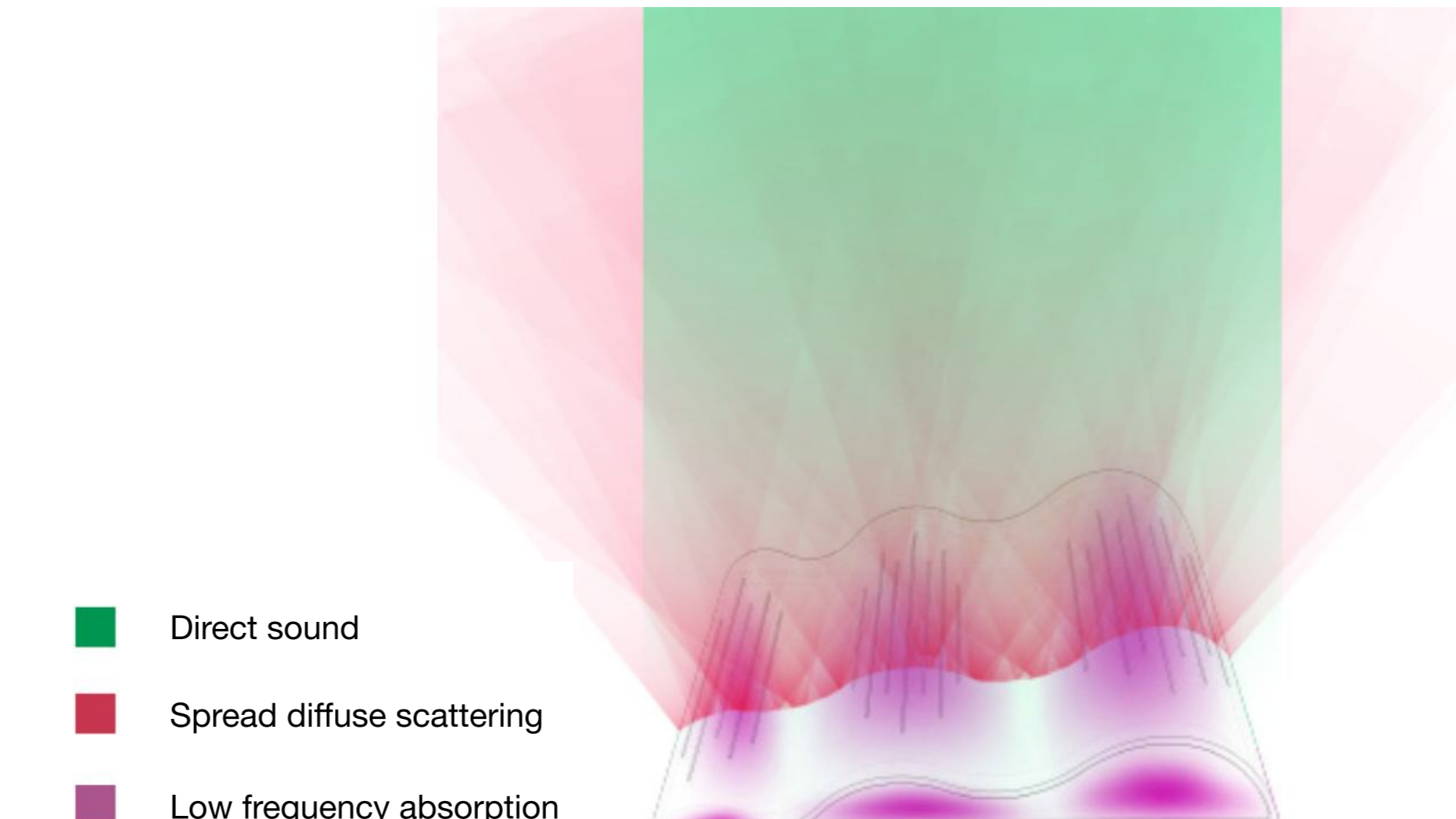
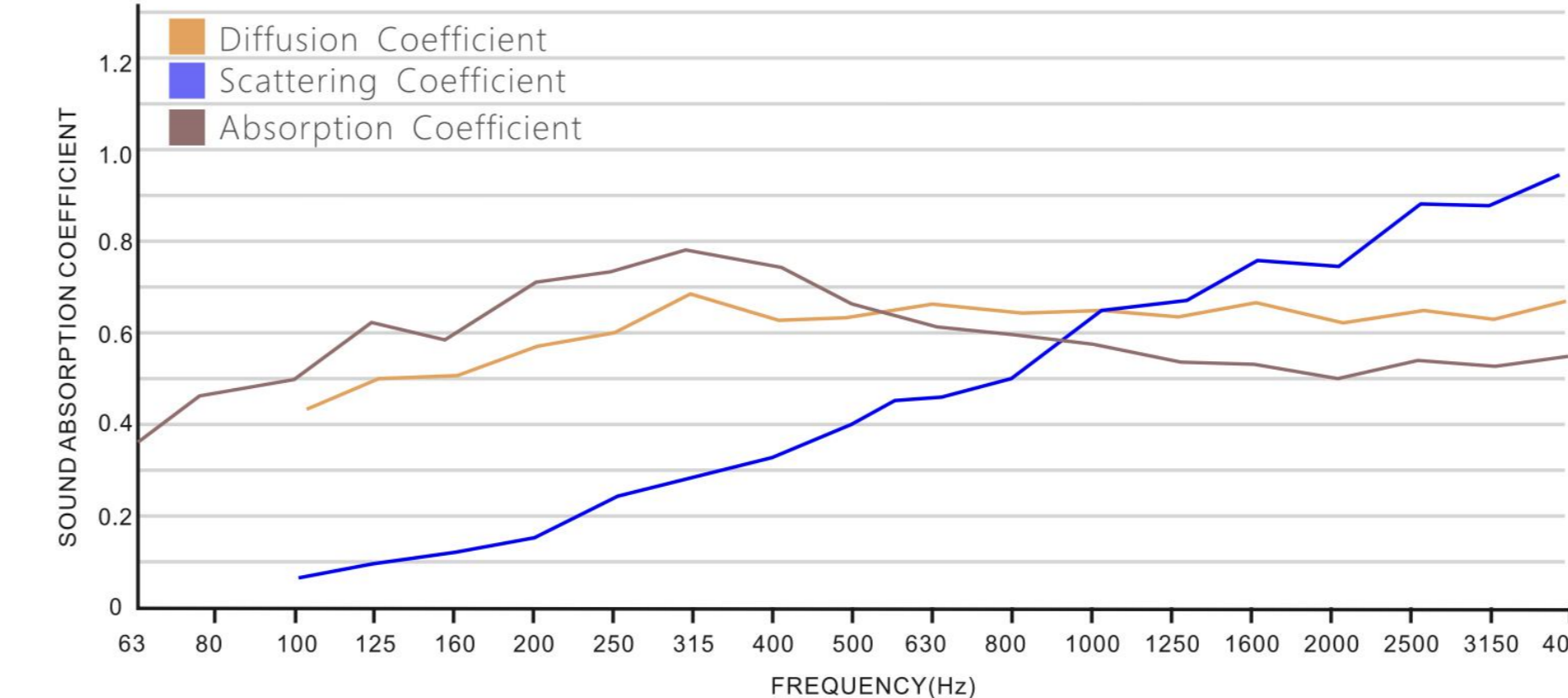

Three wave-shaped diffusion with superimposed double-range bands, Sound absorption with 20% asymmetric design, built-in low-frequency (550-250Hz) absorption cavities with three unequal volumes.

The MLS diffuser horizontally scatters and balances the reflected sound resulting in a more uniformed sound environment without losing sound energy.





Name: Diffuser

Models: PYRAMID 4Q

Eco-Friendly: PU paint, water-based paint, flocking, 100% recyclable

Diffusion indicator: 0.57 /m² [>100Hz-< 5KHz]

Material: HIPS

Weight: 4 Kg/pcs

Size: H600 *W600*D200mm

Package: 2pcs/box

PYRAMID 4Q conical surface diffuser follows the design of 1/4 asymmetrical reflection phases. When the sound waves get in contact with the smooth PYRAMID 4Q conical surface the waves will be reflected in the planned directions to effectively reduce the standing waves and sound flutter on the wall surface.

The cavity under a non equilateral structure is able to absorb low frequency via diaphragm effect which effectively improve sound clearance.

Iregular reflected sound with equal energy will provide a sense of space to human ears and increase the "brightness of sound for diffusion of high and medium frequencies

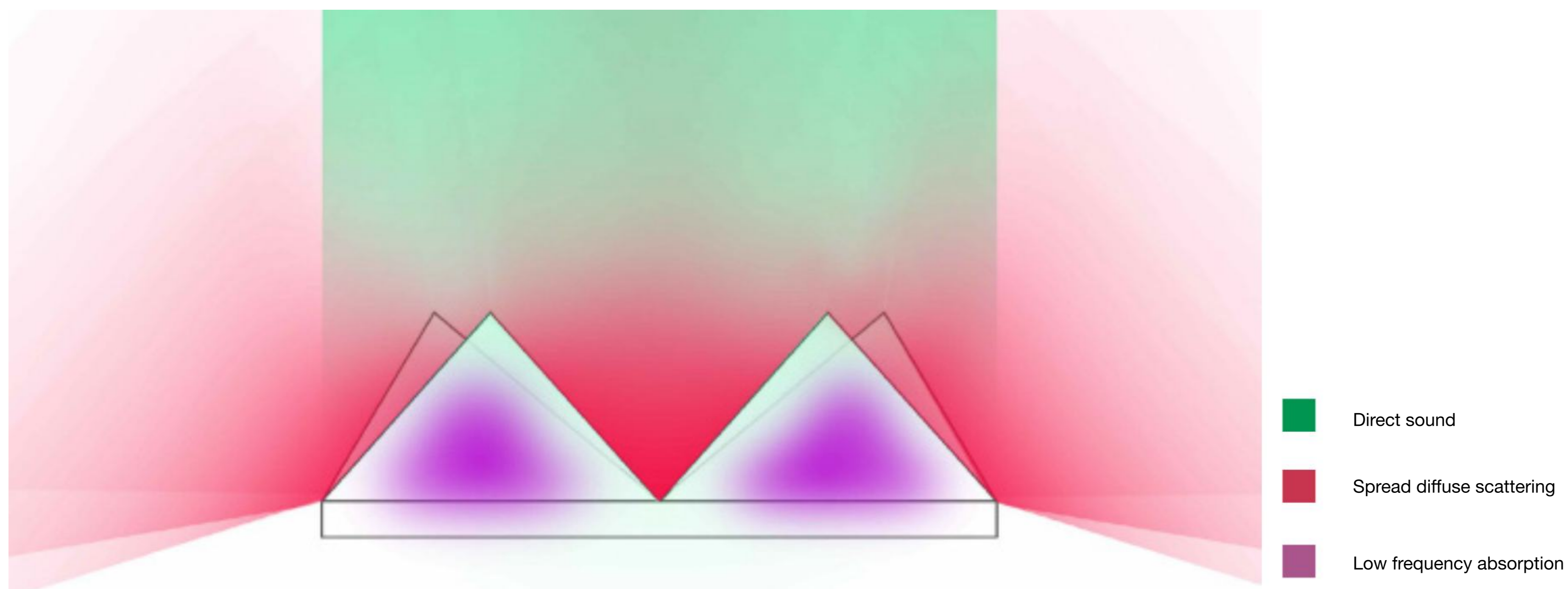
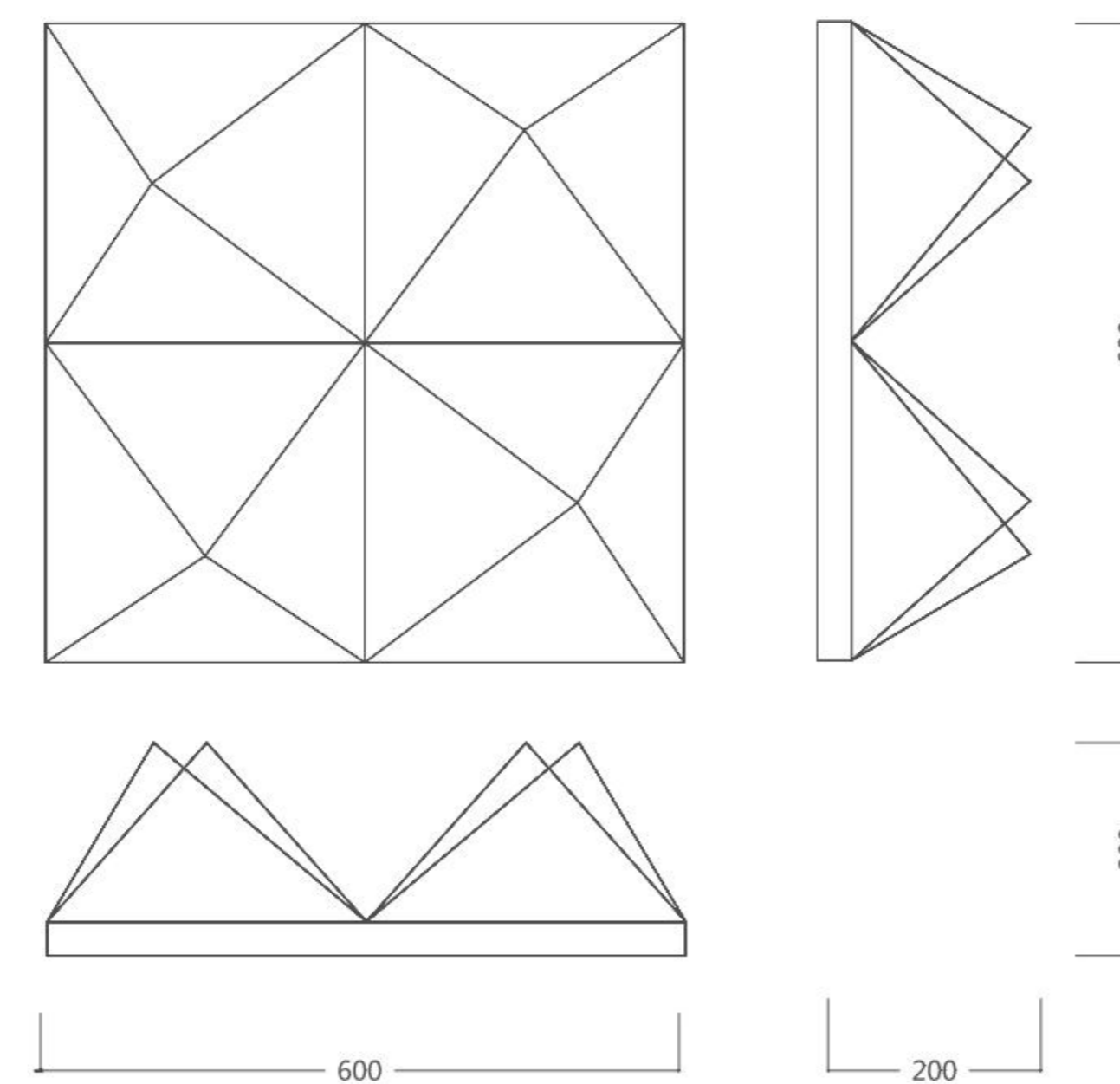
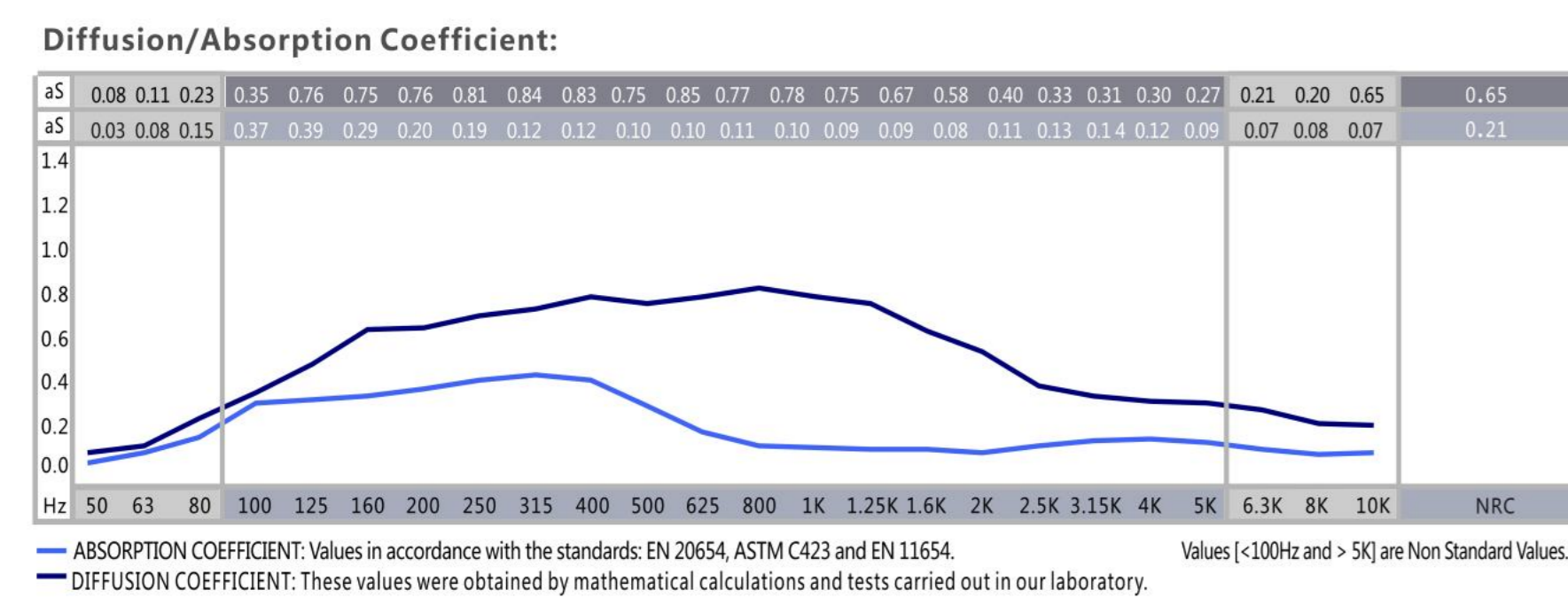

Application Reference

** The following references do not replace professional guidance

Recording room

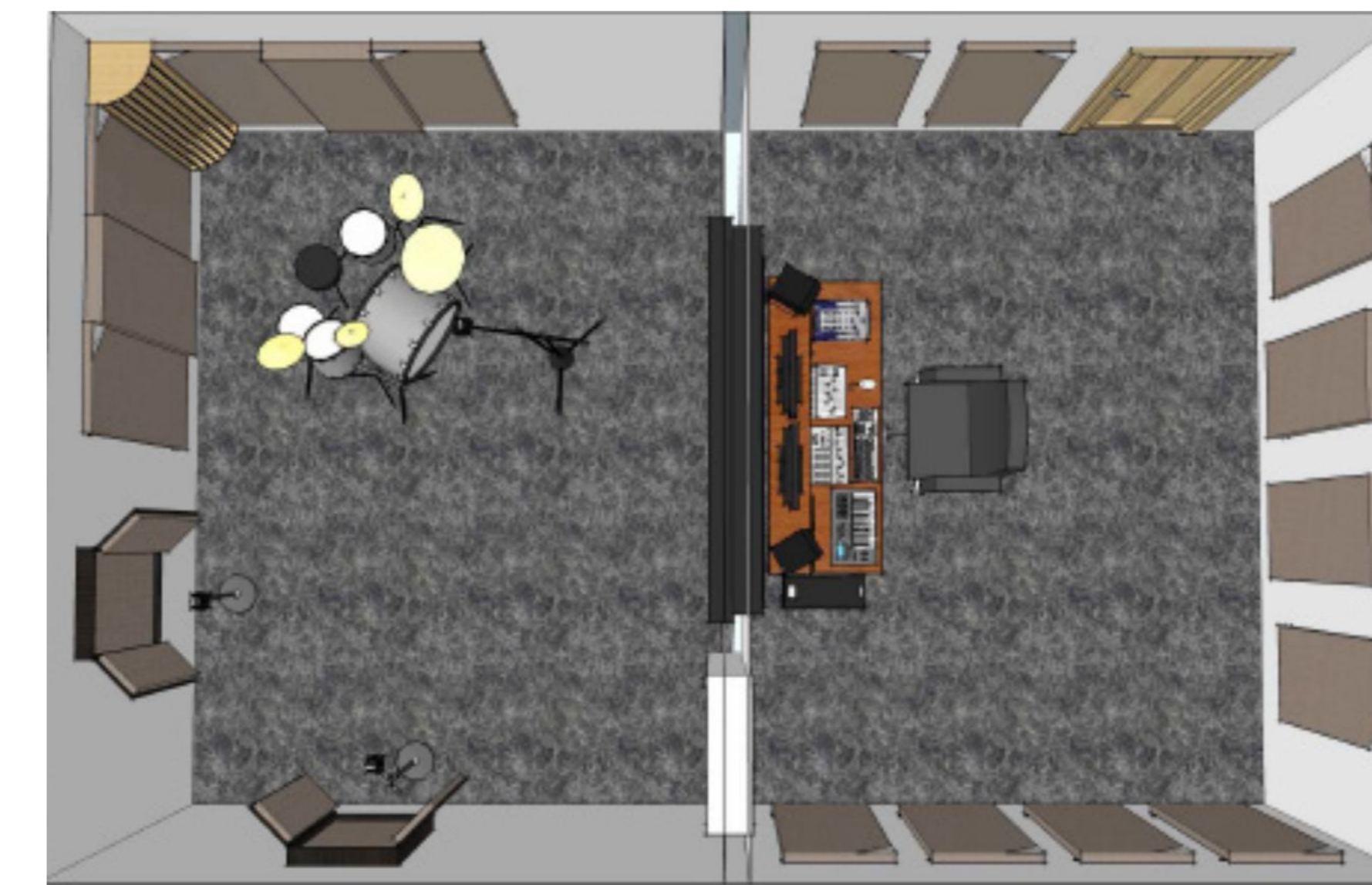

Recording studios often need to deal with sound waves in the range between 150Hz-400Hz which creates a lot of peaks and valleys in the recording which damage the recording quality.

This reference shows how these negative effects can be reduce substantially by effectively absorbing these frequencies.

Home theaters

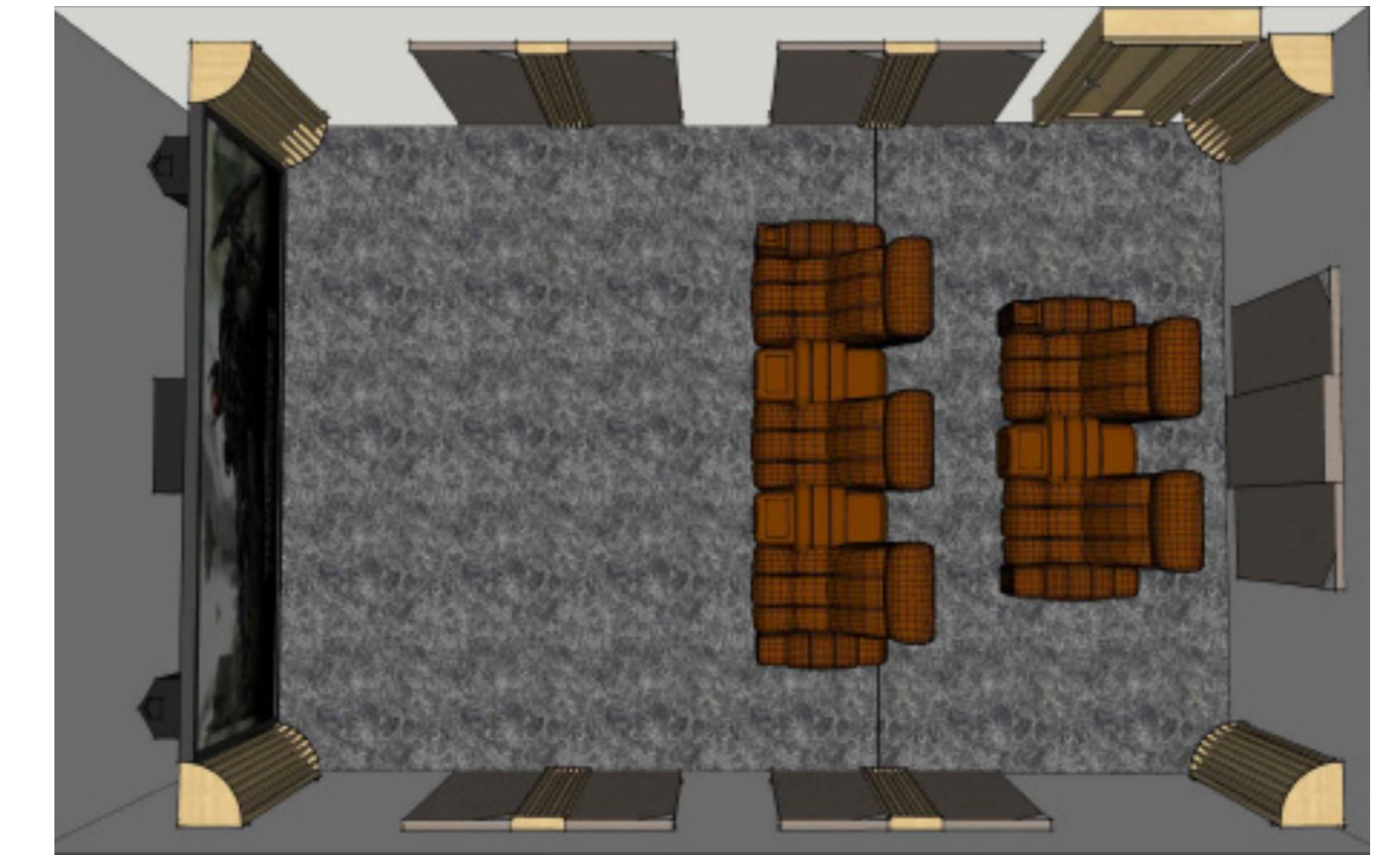

Home theaters demand not only astonishing sound effect but also good overall visual effect matching well with the decoration.

Conference room

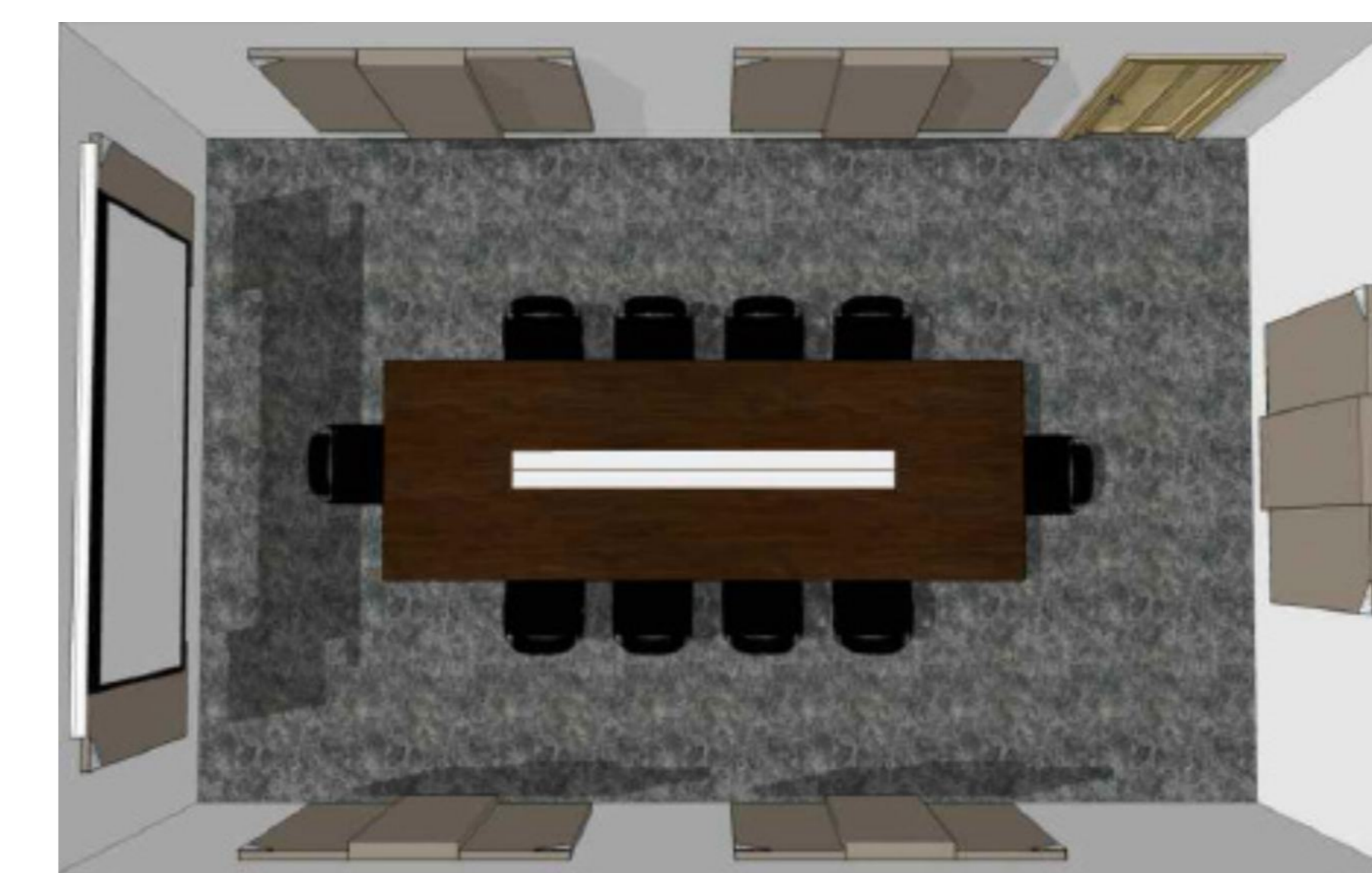

Conference room requires clear voice. Using our product will achieve effective eco control: multiple echo, trembling sound echos, focus and acoustic feedback as well as aesthetic and decorative.



15 m² Audio Studios Examples

EVOs convenient tuning combination can make an empty room into an audio studio room, filling all your requirements immediately.

The products absorb the main reflections on the wall surfaces to the maximum, and inhibit the unfavorable reflection waves. The wave absorbing wall panels control the main reflections and help to reduce the flutter echos and the standing waves.

The major tuning boards are installed on the facade wall surfaces in protection angles to form low frequency traps.

Abundant transparent finish colors for selection to match with all types of decorations.

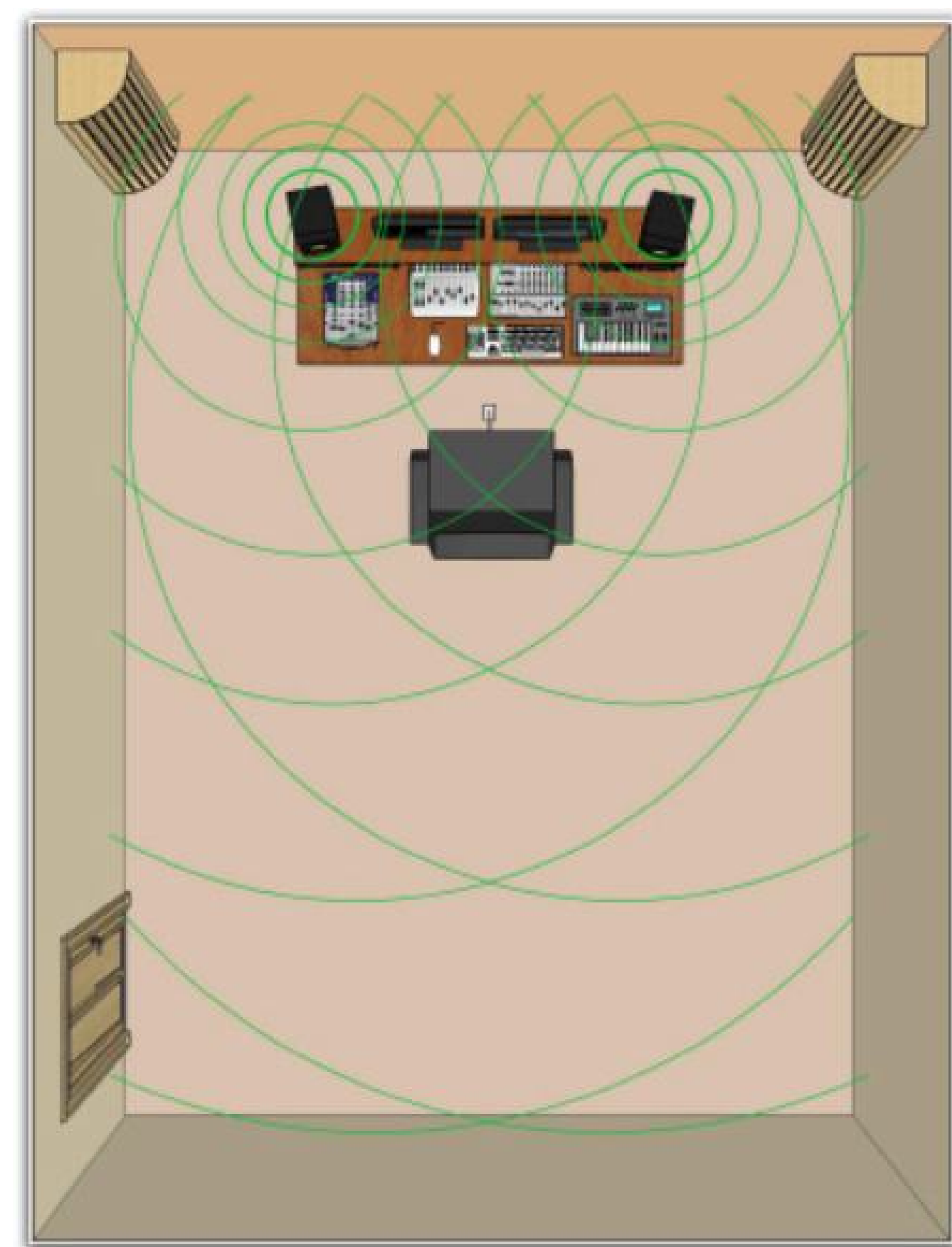

After installation of control bar tuning boards, the main reflection on the side walls are effectively controlled. These high performance panels are critical in controlling the standing waves and the flutter echos, and in the meantime, can reserve the favorable relative reflections to ensure sound balance and accurate stereo imaging.

After effective combination of tuning board, broadband wave absorption is realized by the control bars and corners of the wave absorbing walls. Block walls are also installed at the receiving end. Such a configuration reduces the standing waves and the flutter echos, and reserves the air and sense of space in the room.

The small rooms with abundant low pitch sound often have the acoustic characteristic of obvious peak. Tuning boards are installed in the corners of the audio studios to set up 17" deep back cavity low frequency trap to create more balanced acoustic environments.

Room Acoustic Environment Analysis

The main sound reflection echoes, reflected by the nearby walls and ceiling, cause a strong superposed reflection in the studio. The sound reflected from the walls arrives slightly late and conflicts with the original sound and causes phase offset. The effect of this phenomenon influence several frequencies and called: "Comb Filter" effect and causes auditory fatigue.

Using EVO control column positioned at ear level at two ends will reduce the strongest main room reflection intensity, effectively and immediately create a more accurate auditory space, The brain will stop trying to identify the true sound source and auditory fatigue will be reduced.



Most studios adopts the Lud variation theory to make sound absorption distribute evenly in the room. EVO sound combination adopts the absorption proportion of 60% to regulate the frontend background wall.

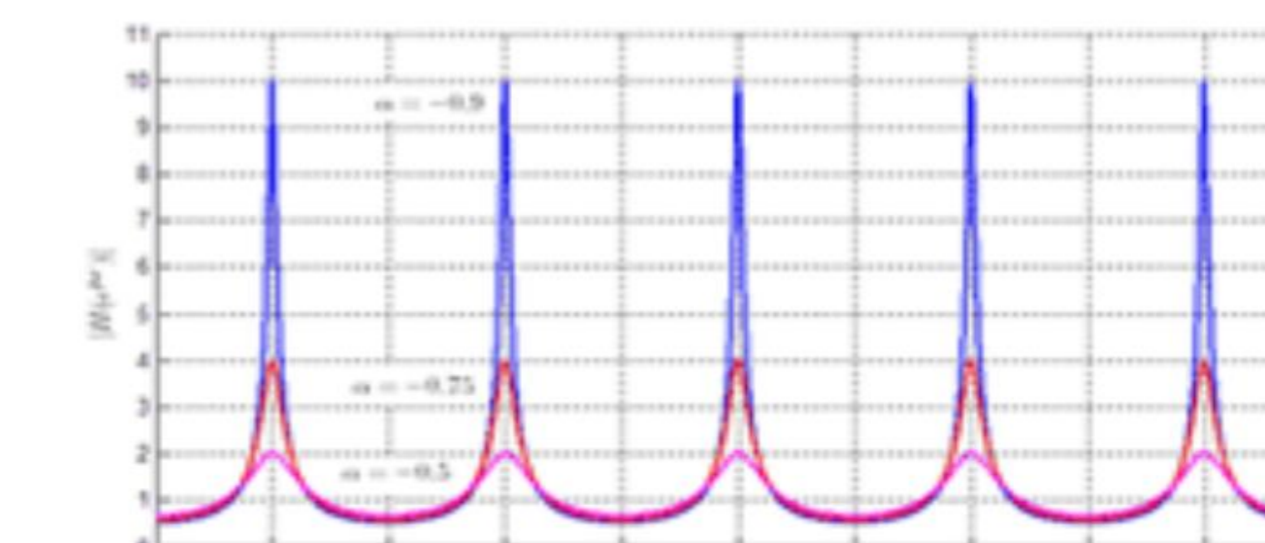

Comb Filter

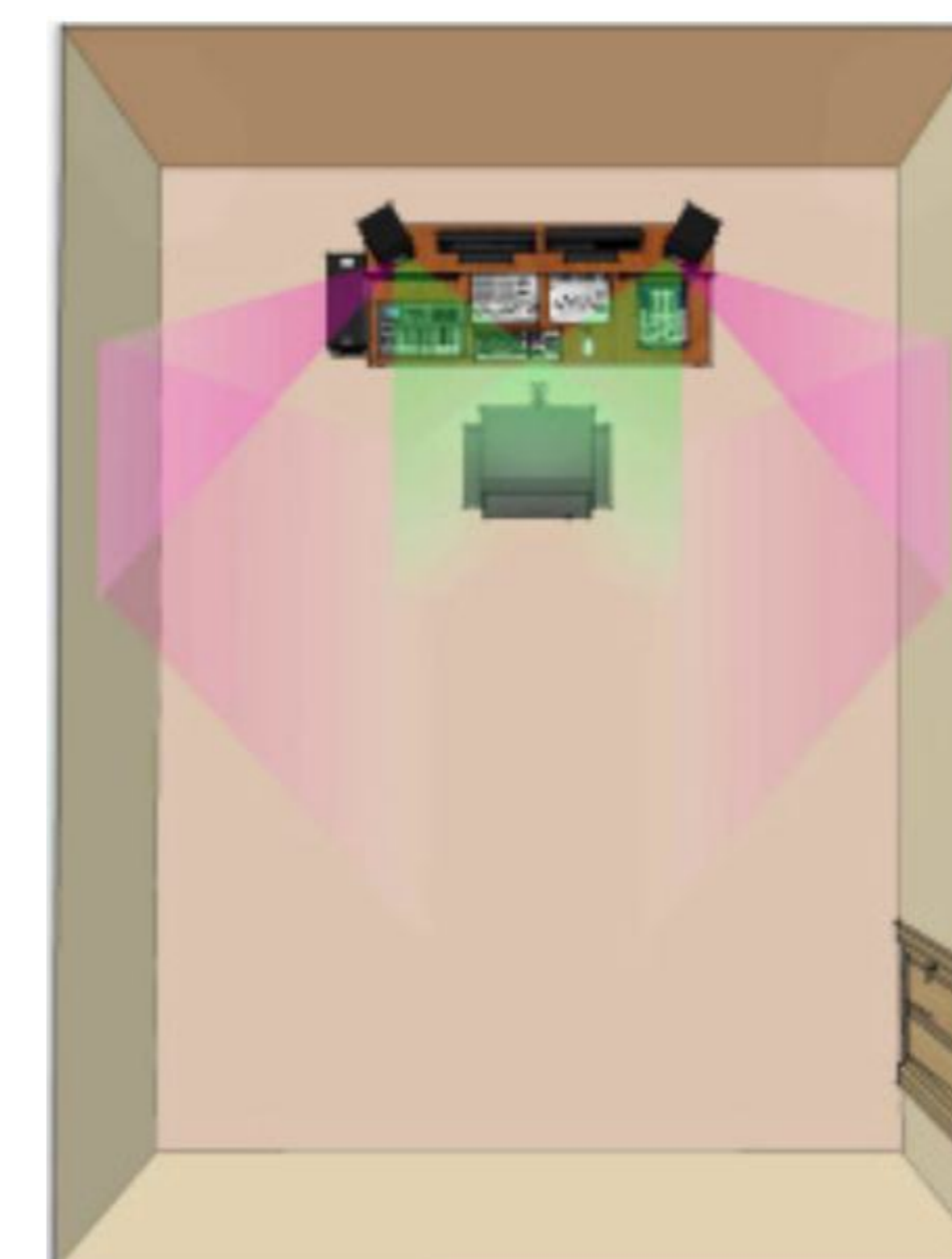

Without acoustic treatment, the reflected sound amplitude is almost as loud as the direct sound source.

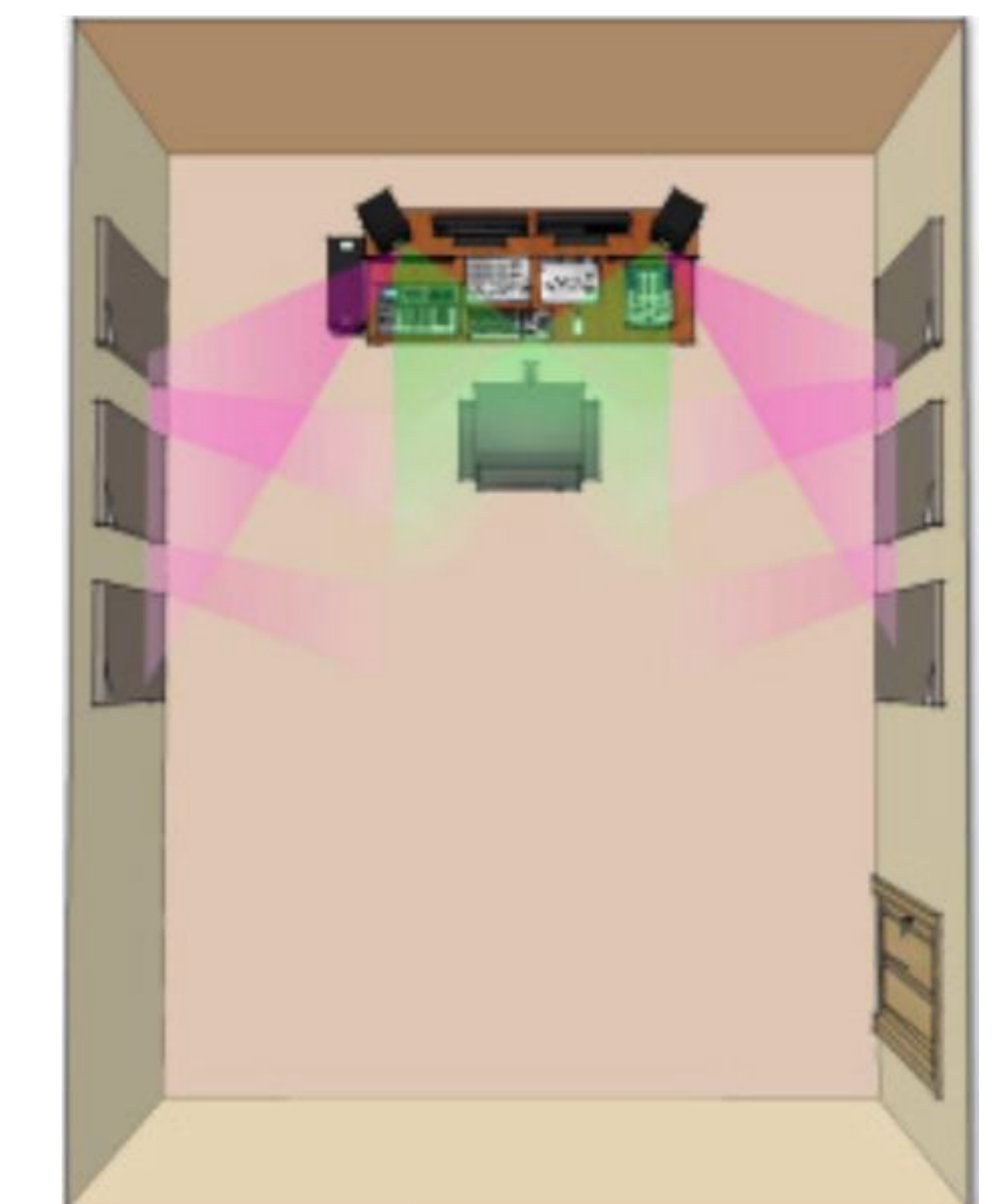

With acoustic control column, the acoustic vibration amplitude is substantially improving the recording process.



Flutter Echo Control

When you clap your hands in an empty room, the sound will bounce of the walls, ceiling and the floor and follow the echo. This effect is known as “Flutter Echo” or “High frequency Chatter”.

EVO multi-combination EQ50T broadband wave absorbing boards will control the flutter echo from one side to the other. The random energy absorption effect is key for Lud room design. some energy sources are allowed to be reflected back to the room keeping the air and space sense, resulting in soft diffusion.

Halls sound environment

Hard surfaces reflects sound waves creating a dense reverberation field and increase the decay time at times to more than 5 seconds, this means that increasing the volume will make the sound become excessively active and it will exceed the room to naturally consume its energy.

The endless rippling echo elongates reverberations making the sound an annoying nightmare.

To prevent this situations the key point is to reduce the sound field and improve the articulation by reducing the decay time to less than 1 second.

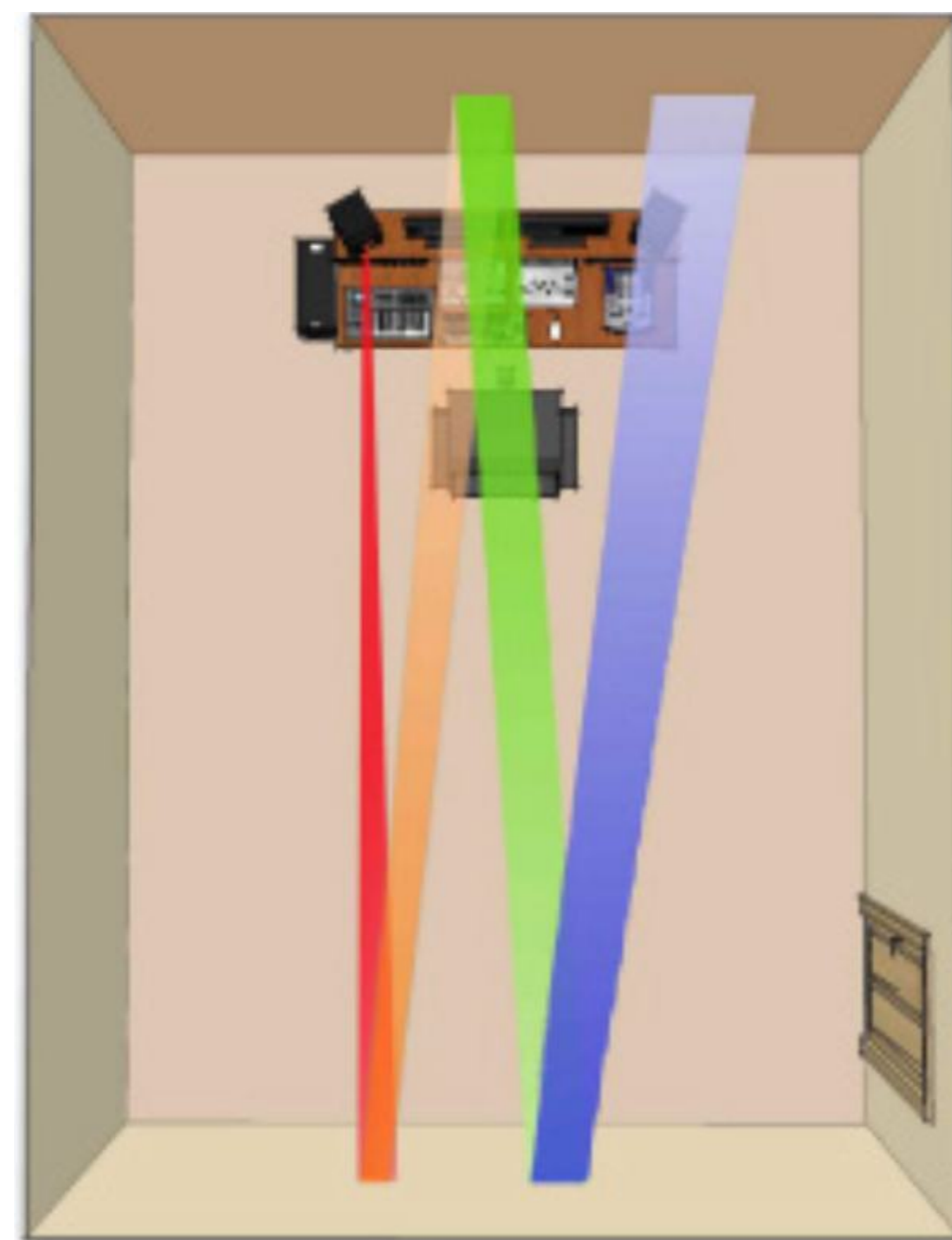

Flutter echos cause excessive reverberation and high wave amplitude.

This makes the acoustic image difficult to position.

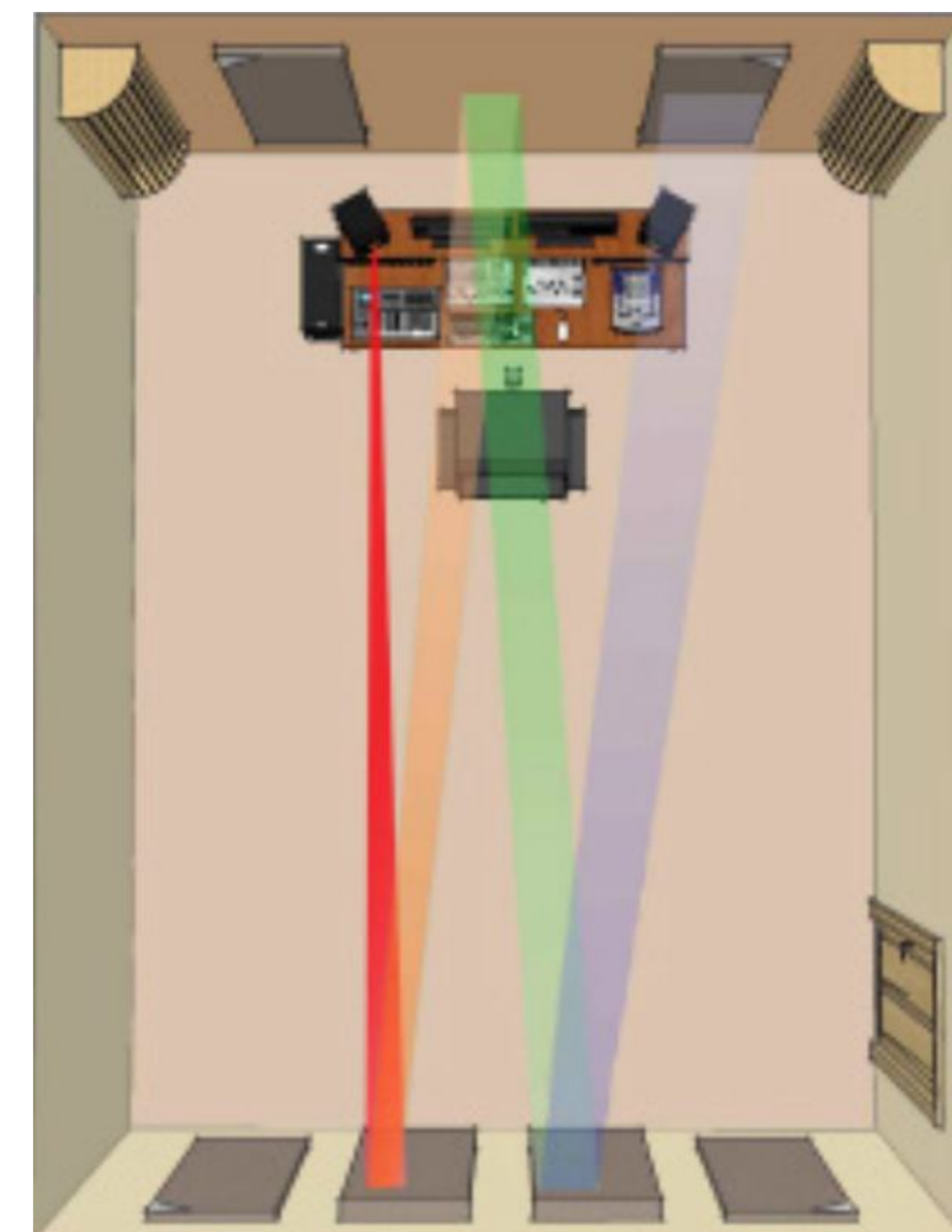

Scattering blocks are matched with other tuning boards, absorbing the flutter echo, softening energy diffusion and reduce standing waves

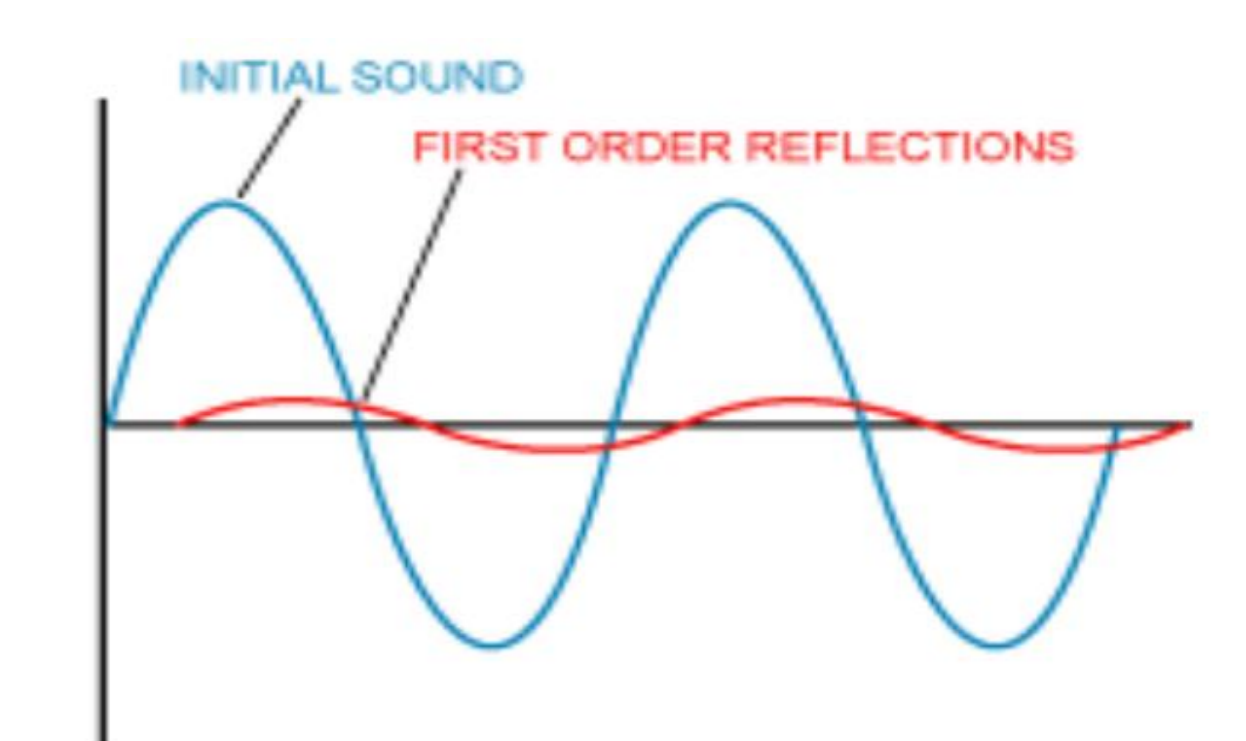
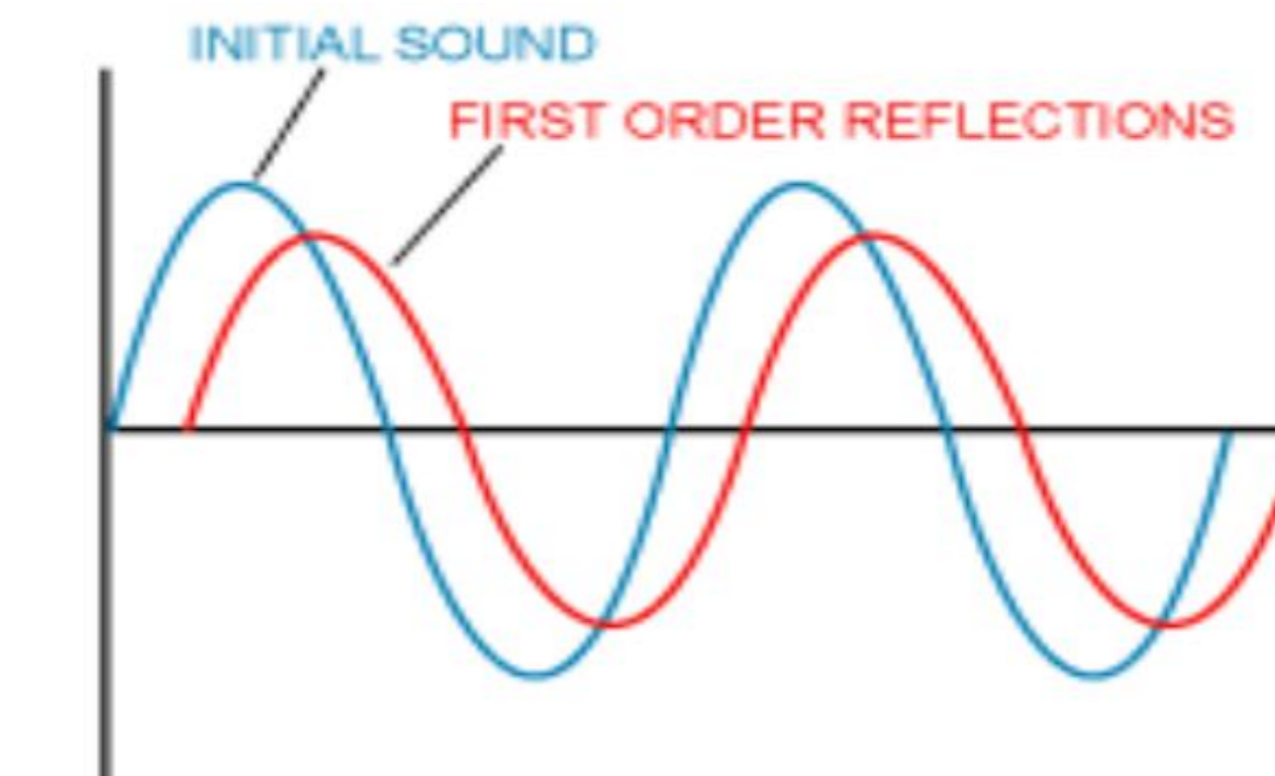
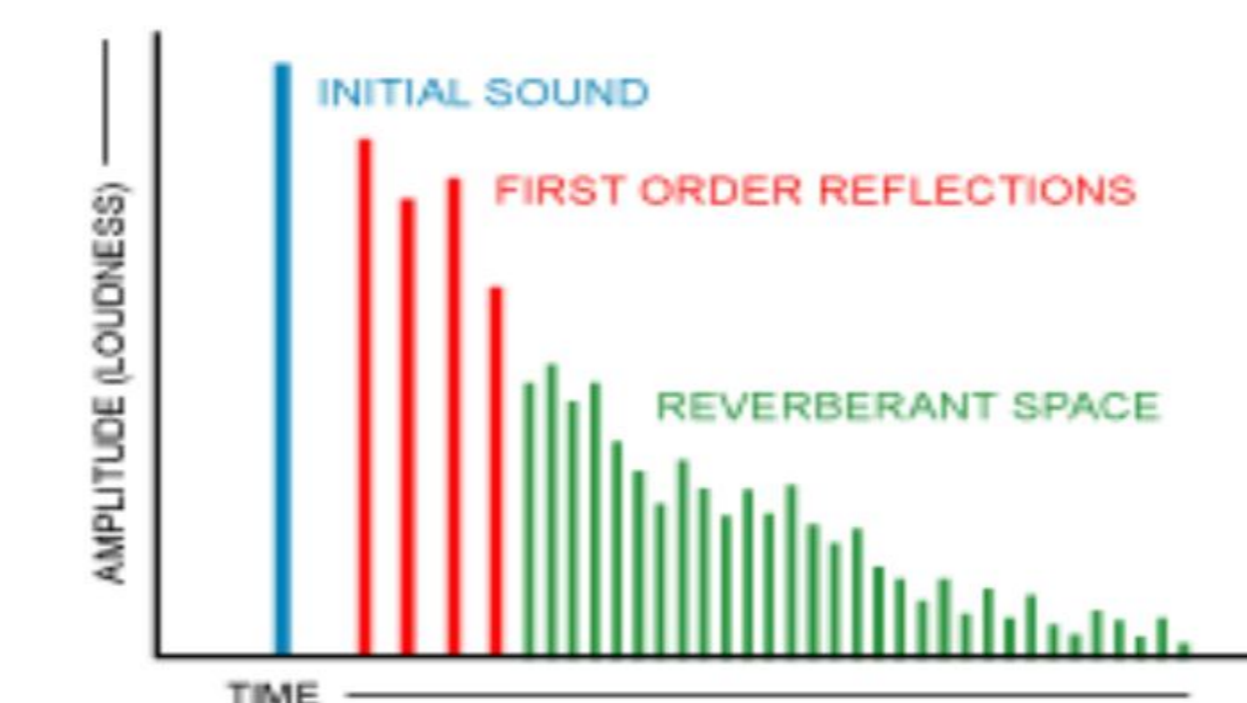
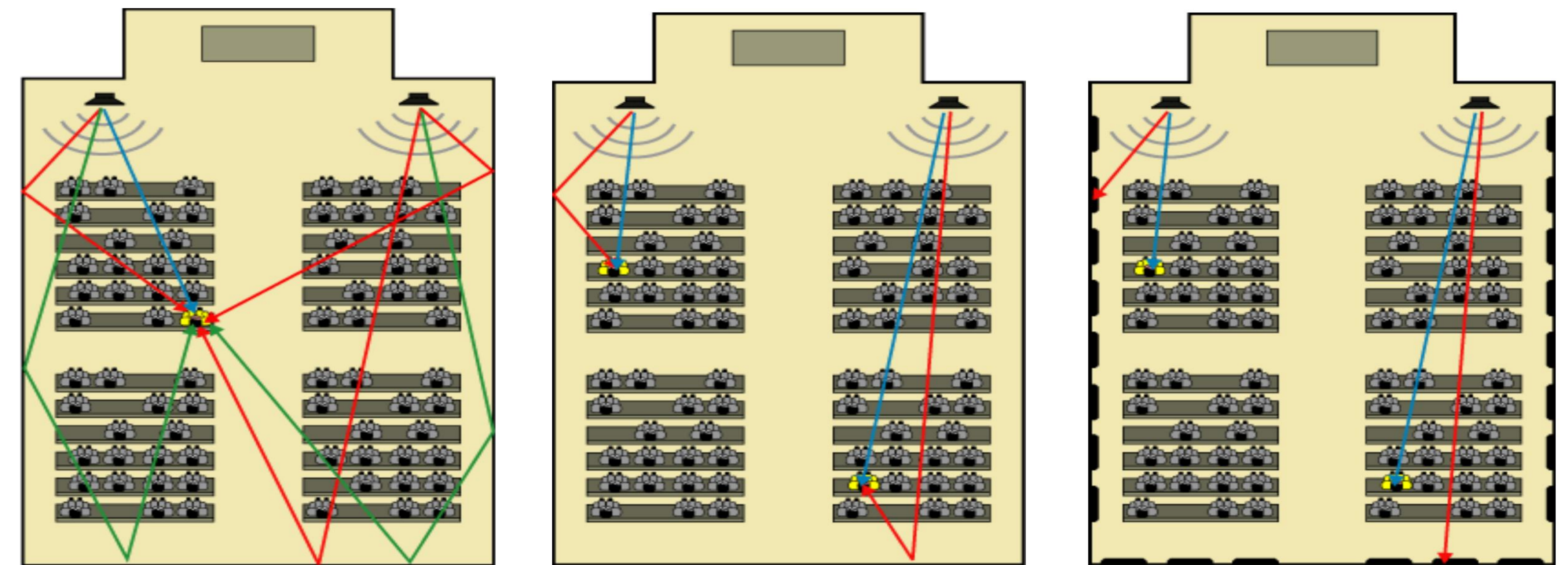
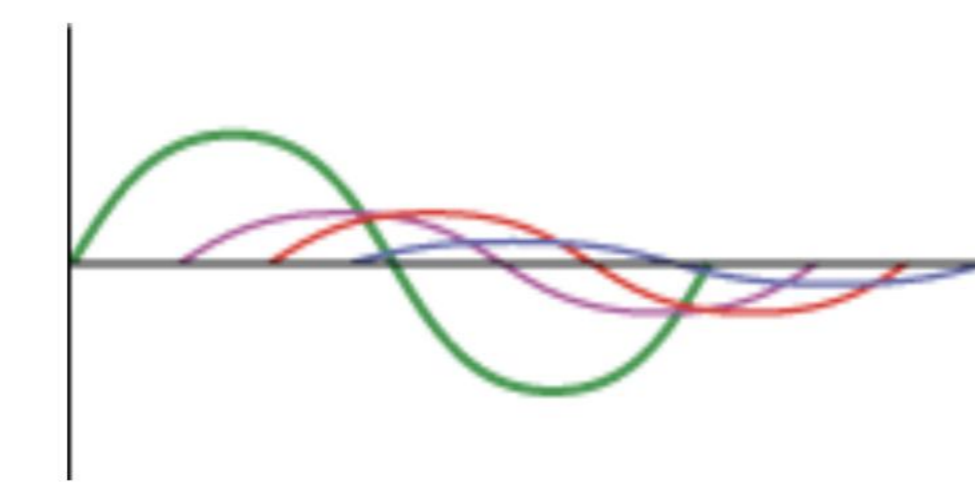



**For More Information:
info@endlessdynamic.com**

All rights reserved by Endless Dynamic 2024 ©